

RS 300R/2016
RS 500R/2016
SM 500R/2016
Ed. 01-2016



RS 300R



RS 500R



SM 500R



Catalogo ricambi
Spare parts catalog
Catalogue pieces de rechange
Ersatzteilkatalog
Catalogo piezas de repuestos



INFORMAZIONI GENERALI

Il presente catalogo serve per richiedere con esattezza le parti di ricambio
Nelle ordinazioni indicare:

- 1) il numero di codice dei particolari seguito dalla descrizione;
- 2) il colore per i pezzi verniciati o comunque colorati;
- 3) il numero di matricola del motociclo, stampigliato sul canotto di sterzo.

Le indicazioni destra e sinistra si riferiscono ai lati del veicolo rispetto al senso di marcia;

GENERAL INFORMATION

The present spare parts list enables one to order exactly the right spare parts.
When ordering specify:

- 1) the part's code number followed by its description;
- 2) indicate colour for painted or coloured parts;
- 3) the motorcycle's serial number, stamped on the steering head.

References to right and left apply to the vehicle in terms of its direction of movement.

INFORMATIONS GENERALES

Ca catalogue permet de commander correctement les pièces de rechange.
Les commandes doivent être passées en indiquant:

- 1) le numéro de code des pièces détachées suivi de leur description;
- 2) le couleur des pièces peintes ou colorés;
- 3) le matricule de la moto, estampillé sur la tige du guidon.

Droite et gauche sont les côtés du véhicule par rapport au sens de la marche.

ALLGEMEINE HINWEISE

Dieser Ersatzteilkatalog dient zur genauen Angabe der Teile bei Ersatzteilbestellungen.

Bei Ersatzbestellung ist folgendes anzugeben:

- 1) Die Bestellnummer der Ersatzteile mit der entsprechenden Beschreibung;
- 2) Farbe für lackierte und farbige Teile angeben;
- 3) Die Sseriennummer des Motorrads, die am Lenkrohr eingepreßt ist.

Die Angaben rechts und links beziehen sich auf das Fahrzeug in Fahrrichtung.

INFORMACIONES GENERALES

El presente catálogo sirve para pedir con exactitud las partes de recambio.
En los pedidos se debe indicar:

- 1) el número de código de la parte y a continuación la descripción;
- 2) el color para las piezas barnizadas o coloreadas;
- 3) el número de matrícula de la motocicleta, estampado en el tubo de dirección.

Las indicaciones derecha e izquierda se refieren a los lados del vehículo respecto del sentido de marcha.

Dati indicativi soggetti a modifiche senza impegno di preavviso.
All data are subject to modification without prior notice.
Données indicatif sujet au modifications sans obligation de préavis.
Anderungen Vorbehalten.
Datos indicativos sujetos a modificaciones sin compromiso de preaviso.

NOTE - LIST - NOTES - NOTE - NOTAS:

- AUS : Australia, Australia, Australie, Australien, Australia
- CDN : Canada, Canada, Canada, Kanada, Canadá
- IT : Italia, Italy, Italie, Italien, Italia
- JAP : Giappone, Japan, Japon, Japan, Japón
- USA : Stati Uniti d'America, United States of America, Etats Units d'Amerique, Vereinigte Staaten von Amerika, Estados Unidos

N° DI MATRICOLA INIZIALE - INITIAL SERIAL NUMBER - MATRICULE INITIAL - BEGINNTESEERIENNUMMER - MATRICULA INICIAL	
MODELLO - MODEL MODELE - MODELL MODELO	MATRICOLA - SERIAL NUMBER MATRICULE - SERIENNUMMER MATRICULA
RS 300R	ZN0A201AAGV000000
RS 500R	ZN0A203AAGV000000
SM 500R	ZN0A203ABGV000000



INDICE – INDEX – INDEX – INHALTSVERZEICHNIS - INDICE

RS 300R/2016
SM 500R - RS 500R/2016

Tavola Drawing Table Bild Tabla	Denominazione	Description	Designation	Bezeichnung	Denominacion	Pagina Page Seite Paja
1	ATTREZZI DI ASSISTENZA, MANUALI E CATALOGHI	SERVICE TOOLS, MANUALS AND CATALOGS	OUTILS D'ASSISTANCE, MANUELS ET CATALOGUES	HILFAUSRÜSTUNG, HANDBUCH UND KATALOG	HERRAMIENTAS DE ASISTENCIA, MANUALES Y CATALOGOS	13
2	CILINDRO, PISTONE	CYLINDER, PISTON	CYLINDRE, PISTON	ZYLINDER, KOLBEN	CILINDRO, PISTON	15
3	TESTA CILINDRO	CYLINDER HEAD	CULASSE	ZYLINDERKOPF	CULATA	17
4	MANOVELLISMO	CRANKSHAFT	VILEBREQUIN	KURBELWELLE	CIGÜEÑAL	25
5	TRASMISSIONE PRIMARIA, FRIZIONE	PRIMARY DRIVE, CLUTCH	TRANSMISSION PRIMAIRE, EMBRAYAGE	PRIMÄRÜBERSETZUNG, KUPPLUNG	TRANSMISION PRIMARIA, EMBRAGUE	27
6	DISTRIBUZIONE	VALVE TIMING	DISTRIBUTION	VENTILSTEUERUNG	DISTRIBUCION	29
7	SEMICARTER SINISTRO	L.H. HALF CRANKCASE	CARTER G.	GEHAUSEDECKEL L.	BANCADA IZQ.	31
8	SEMICARTER DESTRO	R.H. HALF CRANKCASE	CARTER D.	GEHAUSEDECKEL R.	BANCADA DER.	35
9	COPERCHI SEMICARTER DX	R.H. HALF CRANKCASE COVERS	COUVERCLES CARTER D.	GEHAUSEDECKEL R.	TAPAS BANCADA DER.	37
10	COPERCHI SEMICARTER SX	L.H. HALF CRANKCASE COVERS	COUVERCLES CARTER G.	GEHAUSEDECKEL L.	TAPAS BANCADA IZQ.	39
11	LUBRIFICAZIONE	OIL PUMP	PUMPE HUILE	MOTORSCHMIERUNG	LUBRICACION	41
12	CORPO FARFALLATO	THROTTLE BODY	CORP PAPILLON	DROSSELKLAPPENKÖRPER	CUERPO OSCILANTE	45
13	PARTE ELETTRICA, IMPIANTO ELETTRICO	IGNITION SYSTEM, ELECTRIC SYSTEM	PARTIES ELECTRIQUE, INSTALLATION ELECTRIQUE	ELEKTRISCHE TEILE, ELEKTRISHE ANLAGE	PARTE ELECTRICA, INSTALLACION ELECTRICA	47
14	AVVIAMENTO	STARTING	DEMARRAGE	ANLASSER	ARRANQUE	49
15	COMANDO CAMBIO	GEARSHIFT MECHANISM	COMMANDE DE VITESSE	GANGSCHALTUNG	MANDO CAMBIO	51
16	IMPIANTO DI RAFFREDDAMENTO	COOLING SYSTEM	INSTALLATION RAFROIDISSEMENT	SCHMIERUNGSSYSTEM	EQUIPO DE ENFRIAMIENTO	55
17	FILTRO ARIA	AIR FILTER	FILTRE AIRE	LUFTFILTER	FILTRO DE AIRE	59
18	TELAIO, PEDANE	FRAME, FOOT RESTS	CADRE, REPOSE PIEDS	RAHMEN, FUSSBRETT	BASTIDOR, REPOSAPIES	61
19	SOSPENSIONE ANTERIORE (RS 300-500R)	FRONT FORK ASSEMBLY (RS 300-500R)	SUSPENSION AVANT (RS 300-500R)	VORDERTELESKOPGABEL (RS 300-500R)	SUSPENSION DELANTERA (RS 300-500R)	65
19A	SOSPENSIONE ANTERIORE (SM 500R)	FRONT FORK ASSEMBLY (SM 500R)	SUSPENSION AVANT (SM 500R)	VORDERTELESKOPGABEL (SM 500R)	SUSPENSION DELANTERA (SM 500R)	69
20	AMMORTIZZATORE POSTERIORE	REAR SUSPENSION	SUSPENSION ARRIERE	HINTERHAUFHANGUNG	SUSPENSION TRASERA	73
21	LEVRAGGI SOSPENSIONI POSTERIORE	REAR SUSPENSION LINKAGE	LEVIER SUSPENSION ARRIERE	HEBELWERK HINTERHAUFHANGUNG	PALANCA SUSPENSION TRASERA	75
22	FORCELLONE POSTERIORE	REAR SWING ARM	FOURCHE ARRIERE	HINTERGABEL	HORQUILLA TRASERA	77
23	MANUBRIO E COMANDI	HANDLEBAR AND CONTROLS	GUIDON ET COMMANDES	LENKER UND STEUERORGANE	MANILLAR Y MANDOS	81
24	FRENO IDRAULICO POSTERIORE	REAR HYDRAULIC BRAKE	FREIN HYDRAULIQUE ARRIERE	HINTERBREMSE	FRENO HIDRAULICO TRASERO	83
25	PANNELLI, PARAFANGHI, SELLA	PANEL, FENDERS, SEAT,	PANNEAU, GARDE-BOUES, SIEGE,	STREIFEN, KOTFLUGEL, SATTEL	PANELO, GUARDABARROS, SILLIN	85
26	SERBATOIO CARBURANTE, CONVOGIATORI	GAS TANK, PANEL	RESERVOIR CARBURANT, FLANC	KRAFTSTOFFBEHALTER, FLANKE	DEPOSITO GASOLINA, LATERAL	89
27	SCARICO	EXHAUST SYSTEM	TUYAU D'ECHAPPEMENT	AUSPUFFROHR	TUBO DE ESCAPE	91
28	FRENO IDRAULICO ANT. (RS 300-500R)	FRONT HYDRAULIC BRAKE (RS 300-500R)	FREIN HYDRAULIQUE AVANT (RS 300-500R)	VORDERBREMSE (RS 300-500R)	FRENO HIDRAULICO DELANTERO (RS 300-500R)	95
28A	FRENO IDRAULICO ANT. (SM 500R)	FRONT HYDRAULIC BRAKE (SM 500R)	FREIN HYDRAULIQUE AVANT (SM 500R)	VORDERBREMSE (SM 500R)	FRENO HIDRAULICO DEL. (SM 500R)	97



INDICE – INDEX – INDEX – INHALTSVERZEICHNIS - INDICE

RS 300R/2016
SM 500R - RS 500R/2016

Tavola Drawing Table Bild Tabla	Denominazione	Description	Designation	Bezeichnung	Denominacion	Pagina Page Page Seite Paja
29	RUOTA ANTERIORE (RS 300-500R)	FRONT WHEEL (RS 300-500R)	ROUE AVANT (RS 300-500R)	VORTERRAD (RS 300-500R)	RUEDA DELANTERA (RS 300-500R)	99
29A	RUOTA ANTERIORE (SM 500R)	FRONT WHEEL (SM 500R)	ROUE AVANT (SM 500R)	VORTERRAD (SM 500R)	RUEDA DELANTERA (SM 500R)	101
30	RUOTA POSTERIORE	REAR WHEEL	ROUE ARRIERE	HINTERRAD	RUEDA TRASERA	103
31	STRUMENTO DIGITALE	DIGITAL INSTRUMENT,	INSTRUMENT DIGITAL	DIGITAL TACHOMETER	INSTRUMENTO DIGITAL	105
32	GRUPPO CAVI, PARTI ELETTRICHE	MAIN WIRING HARNESS, ELECTRICAL PARTS	CABLES PRINCIPAL, PARTIES ELECTRIQUES	KABEL, ELEKTRISCHE KOMPONENTE	GRUPO PRINCIPAL CABLES PARTES ELECTRICAS	107
33	DECALCOMANIE (RS 300R)	TRANSFER (RS 300R)	DECALCOMANIE (RS 300R)	ABZIEHBILD (RS 300R)	CALCOMANIA (RS 300R)	111
34	DECALCOMANIE (RS 500R)	TRANSFER (RS 500R)	DECALCOMANIE (RS 500R)	ABZIEHBILD (RS 500R)	CALCOMANIA (RS 500R)	113
35	DECALCOMANIE (SM 500R)	TRANSFER (SM 500R)	DECALCOMANIE (SM 500R)	ABZIEHBILD (SM 500R)	CALCOMANIA (SM 500R)	115



INDICE - INDEX - INDEX - INHALTSVERZEICHNIS - INDICE

RS 300R/2016
SM 500R - RS 500R/2016

Tavola - Drawing - Table - Bild - Tabla

1

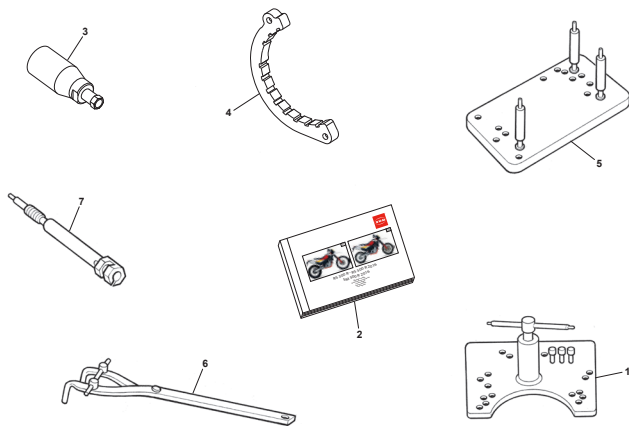

Pagina - Page - Page - Seite - Paja

12

Tavola - Drawing - Table - Bild - Tabla

2

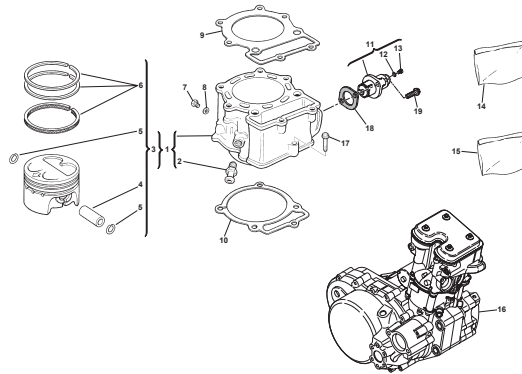

Pagina - Page - Page - Seite - Paja

14

Tavola - Drawing - Table - Bild - Tabla

3

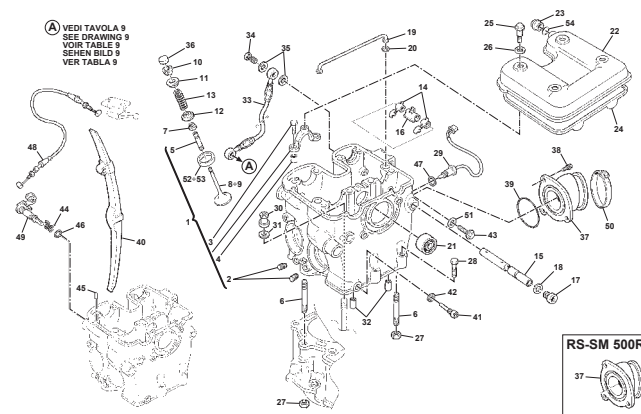

Pagina - Page - Page - Seite - Paja

16

Tavola - Drawing - Table - Bild - Tabla

4

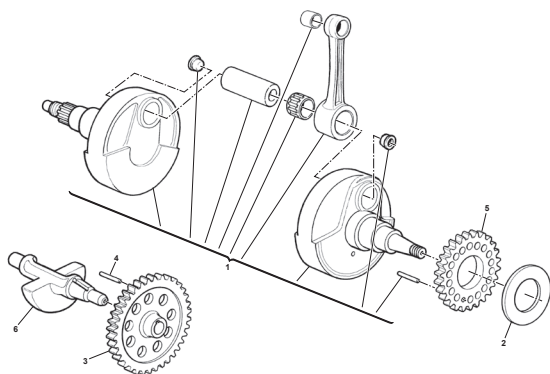

Pagina - Page - Page - Seite - Paja

24

Tavola - Drawing - Table - Bild - Tabla

5

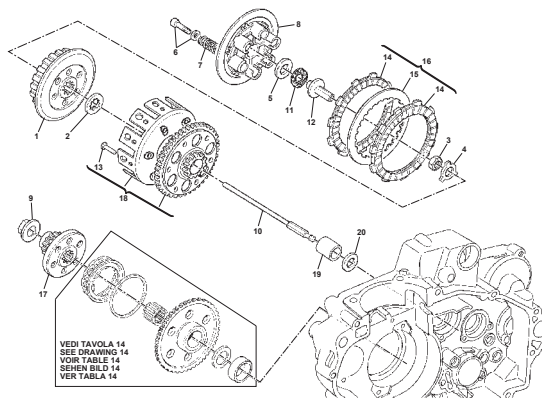

Pagina - Page - Page - Seite - Paja

26

Tavola - Drawing - Table - Bild - Tabla

6

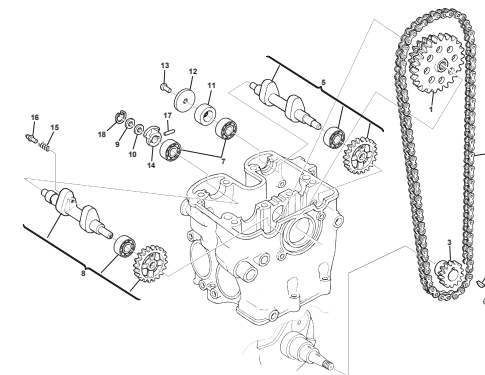

Pagina - Page - Page - Seite - Paja

28

Tavola - Drawing - Table - Bild - Tabla

7

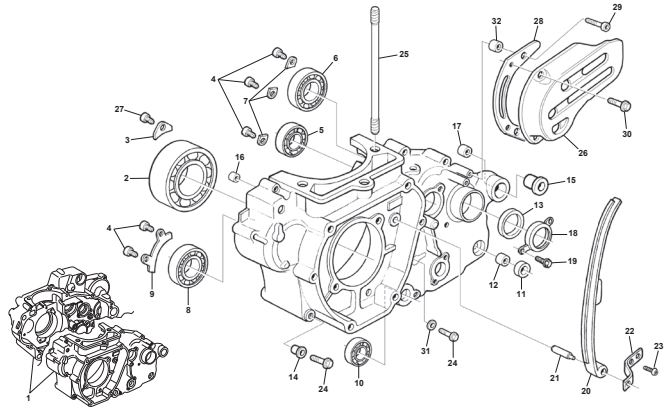

Pagina - Page - Page - Seite - Paja

30

Tavola - Drawing - Table - Bild - Tabla

8

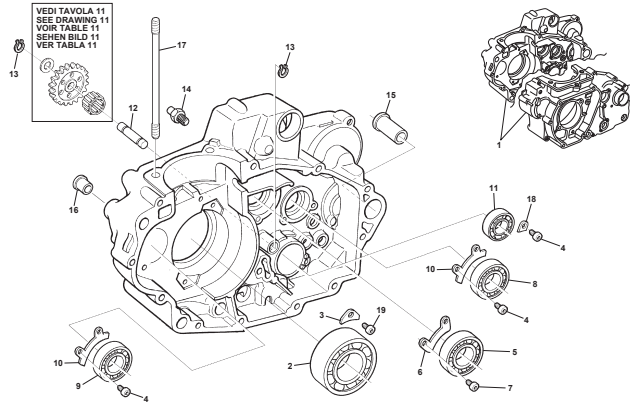

Pagina - Page - Page - Seite - Paja

34

Tavola - Drawing - Table - Bild - Tabla

9

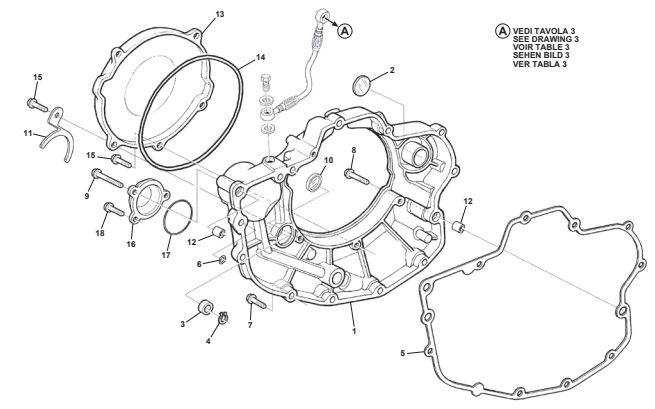

Pagina - Page - Page - Seite - Paja

36

Tavola - Drawing - Table - Bild - Tabla

10

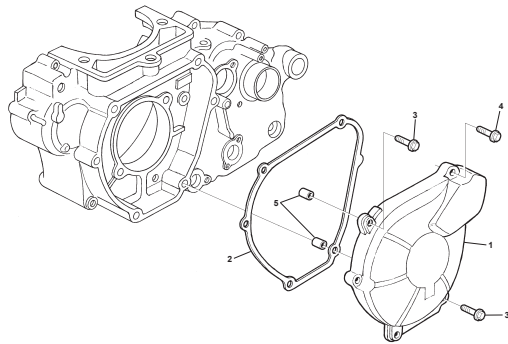

Pagina - Page - Page - Seite - Paja

38

Tavola - Drawing - Table - Bild - Tabla

11

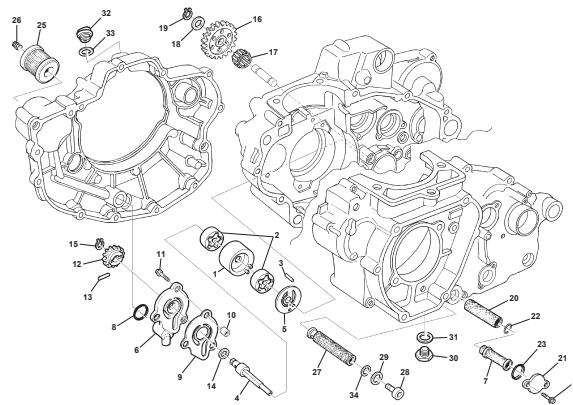

Pagina - Page - Page - Seite - Paja

40

Tavola - Drawing - Table - Bild - Tabla

12

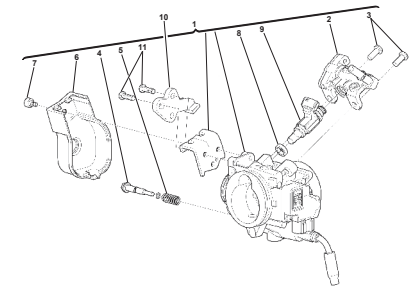

Pagina - Page - Page - Seite - Paja

44



INDICE - INDEX - INDEX - INHALTSVERZEICHNIS - INDICE

RS 300R/2016
SM 500R - RS 500R/2016

Tavola - Drawing - Table - Bild - Tabla

13

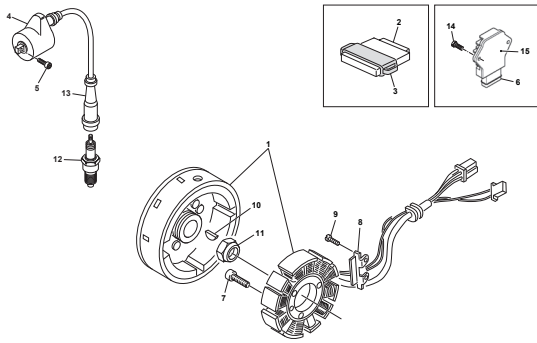

Pagina - Page - Page - Seite - Paja

46

Tavola - Drawing - Table - Bild - Tabla

14

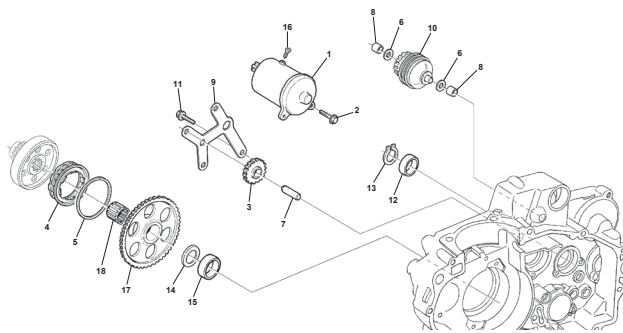

Pagina - Page - Page - Seite - Paja

48

Tavola - Drawing - Table - Bild - Tabla

15

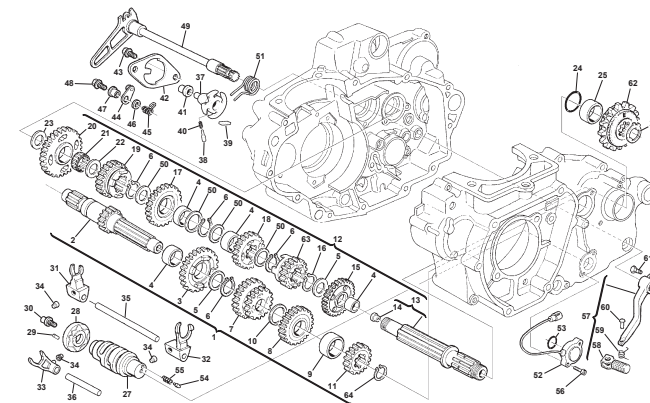

Pagina - Page - Page - Seite - Paja

50

Tavola - Drawing - Table - Bild - Tabla

16

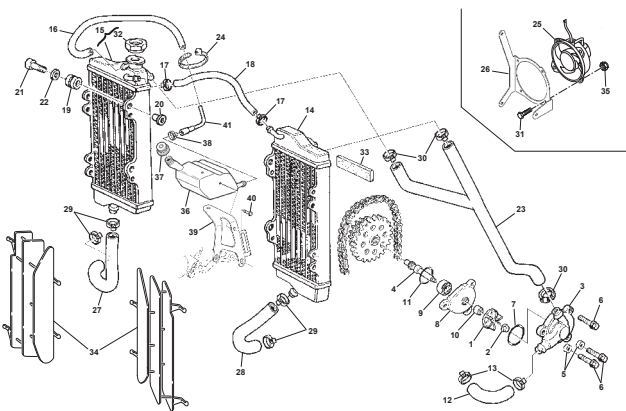

Pagina - Page - Page - Seite - Paja

54

Tavola - Drawing - Table - Bild - Tabla

17

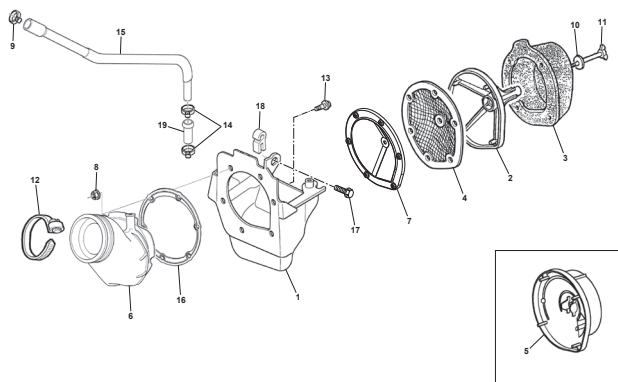

Pagina - Page - Page - Seite - Paja

58

Tavola - Drawing - Table - Bild - Tabla

18

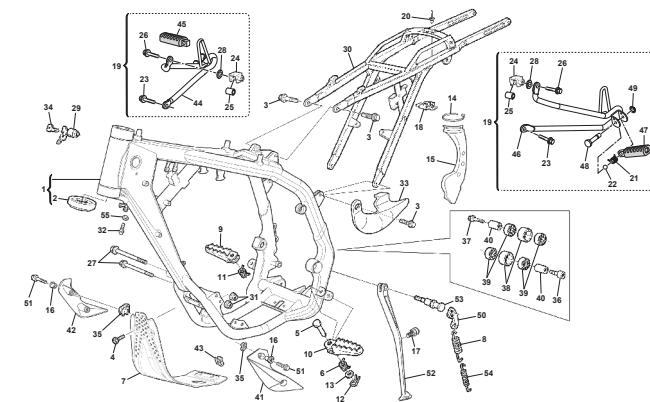

Pagina - Page - Page - Seite - Paja

60

Tavola - Drawing - Table - Bild - Tabla

19

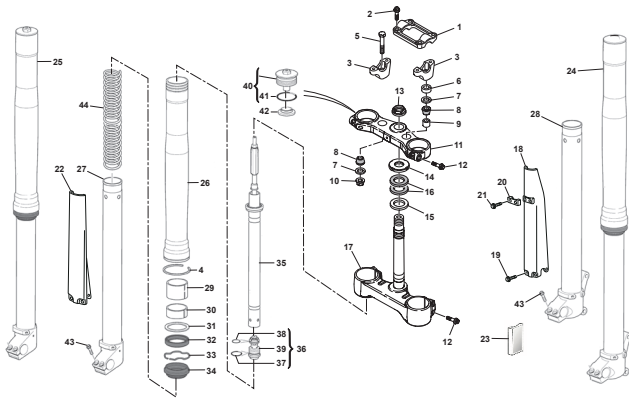

Pagina - Page - Page - Seite - Paja

64

Tavola - Drawing - Table - Bild - Tabla

19A

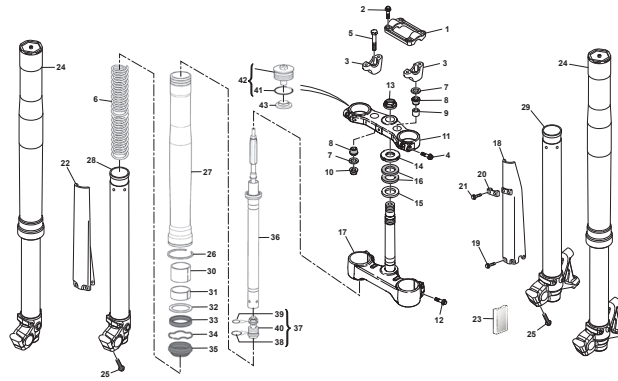

Pagina - Page - Page - Seite - Paja

68

Tavola - Drawing - Table - Bild - Tabla

20

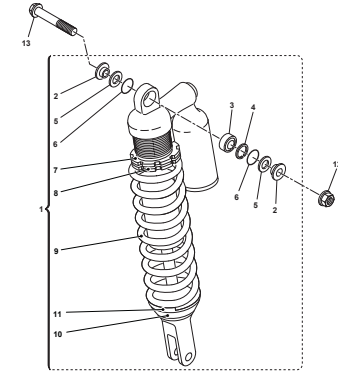

Pagina - Page - Page - Seite - Paja

72

Tavola - Drawing - Table - Bild - Tabla

21

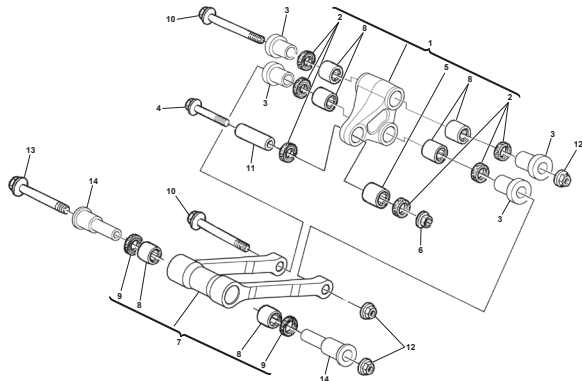

Pagina - Page - Page - Seite - Paja

74

Tavola - Drawing - Table - Bild - Tabla

22

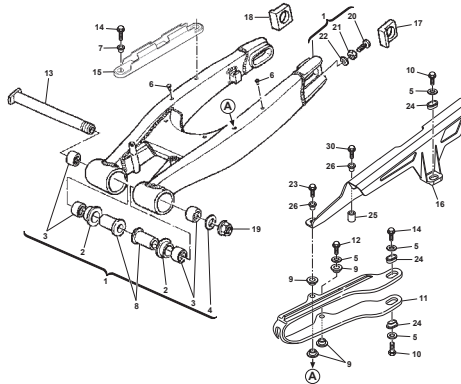

Pagina - Page - Page - Seite - Paja

76



Tavola - Drawing - Table - Bild - Tabla

23

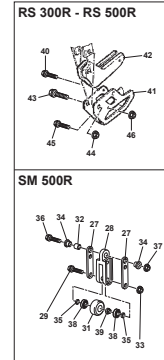
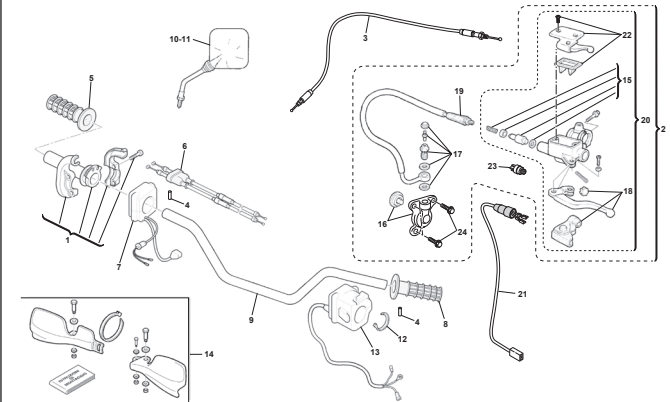

Pagina - Page - Page - Seite - Paja

80

Tavola - Drawing - Table - Bild - Tabla

24

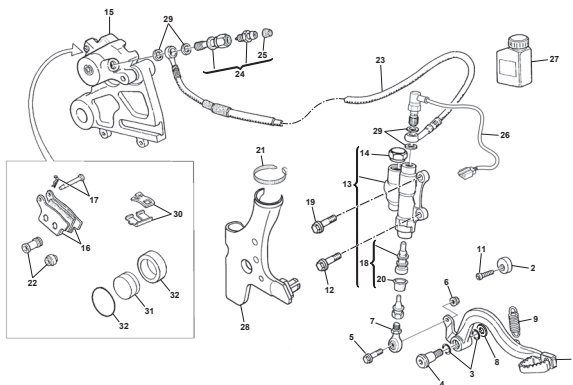

Pagina - Page - Page - Seite - Paja

82

Tavola - Drawing - Table - Bild - Tabla

25

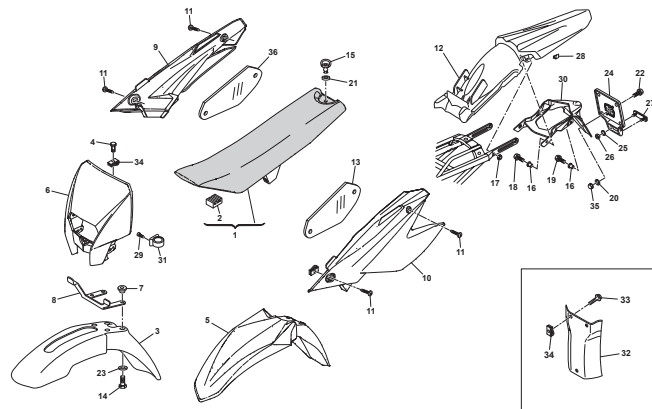

Pagina - Page - Page - Seite - Paja

84

Tavola - Drawing - Table - Bild - Tabla

26

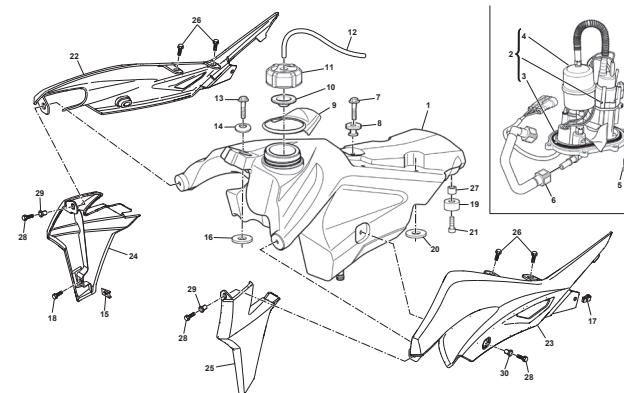

Pagina - Page - Page - Seite - Paja

88

Tavola - Drawing - Table - Bild - Tabla

27

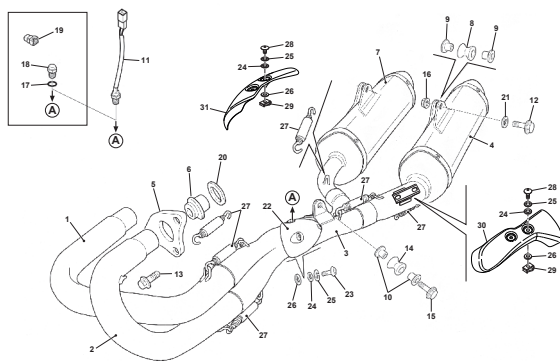

Pagina - Page - Page - Seite - Paja

90

Tavola - Drawing - Table - Bild - Tabla

28

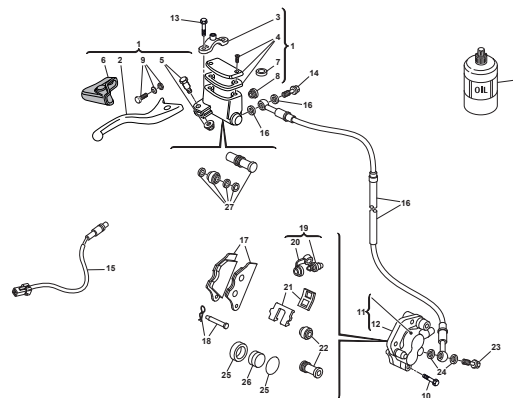

Pagina - Page - Page - Seite - Paja

94

Tavola - Drawing - Table - Bild - Tabla

28A

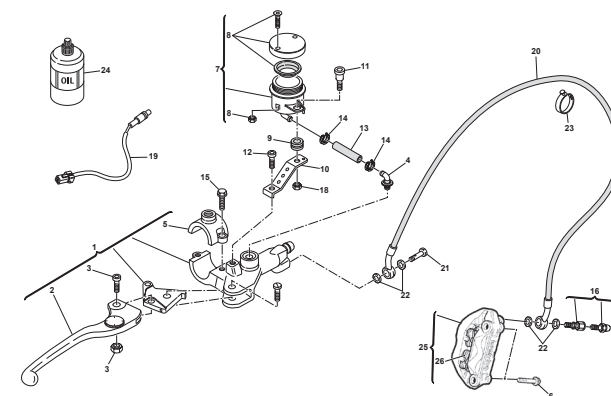

Pagina - Page - Page - Seite - Paja

96

Tavola - Drawing - Table - Bild - Tabla

29

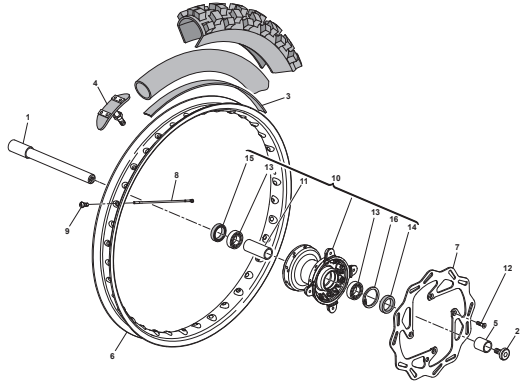

Pagina - Page - Page - Seite - Paja

98

Tavola - Drawing - Table - Bild - Tabla

29A

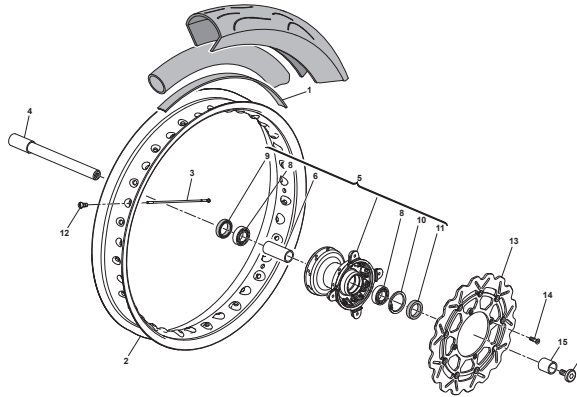

Pagina - Page - Page - Seite - Paja

100

Tavola - Drawing - Table - Bild - Tabla

30

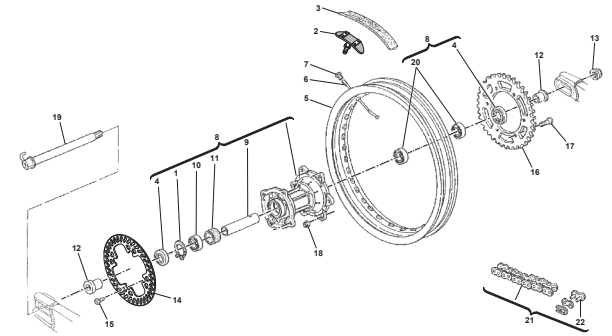

Pagina - Page - Page - Seite - Paja

102

Tavola - Drawing - Table - Bild - Tabla

31

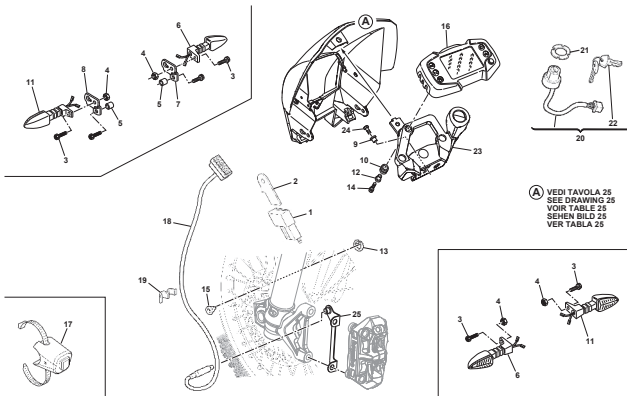

Pagina - Page - Page - Seite - Paja

104

Tavola - Drawing - Table - Bild - Tabla

32

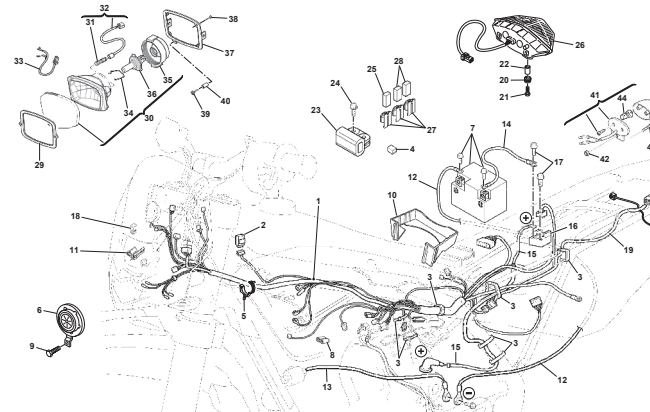

Pagina - Page - Page - Seite - Paja

106

Tavola - Drawing - Table - Bild - Tabla

33

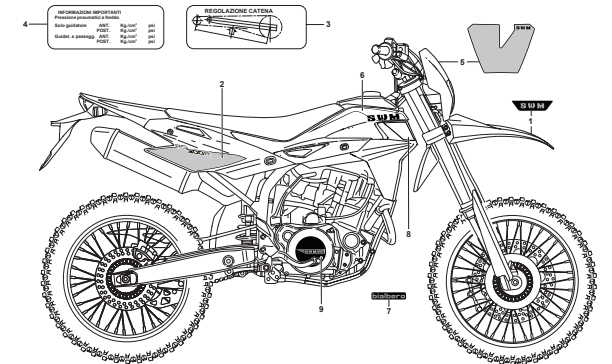

Pagina - Page - Page - Seite - Paja

110



INDICE - INDEX - INDEX - INHALTSVERZEICHNIS - INDICE

RS 300R/2016
SM 500R - RS 500R/2016

Tavola - Drawing - Table - Bild - Tabla

34

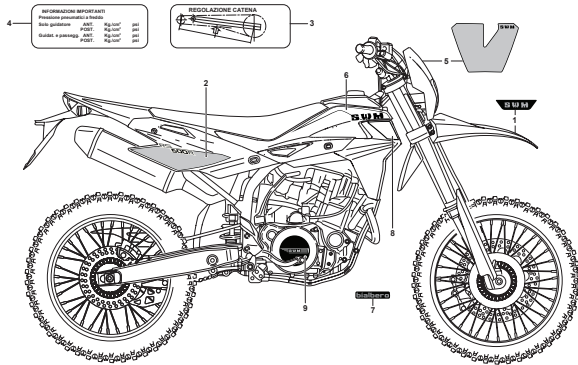

Pagina - Page - Page - Seite - Paja

112

Tavola - Drawing - Table - Bild - Tabla

35

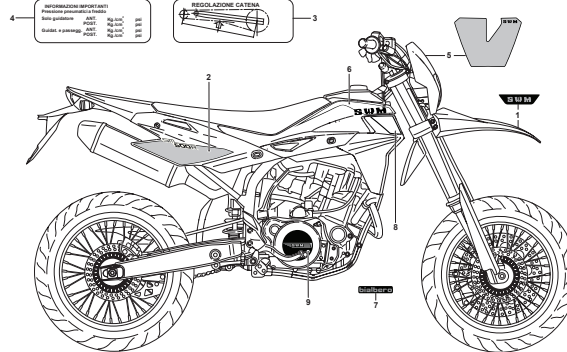

Pagina - Page - Page - Seite - Paja

114

Tavola - Drawing - Table - Bild - Tabla

Tavola - Drawing - Table - Bild - Tabla

Tavola - Drawing - Table - Bild - Tabla

Tavola - Drawing - Table - Bild - Tabla

Pagina - Page - Page - Seite - Paja

Pagina - Page - Page - Seite - Paja

Pagina - Page - Page - Seite - Paja

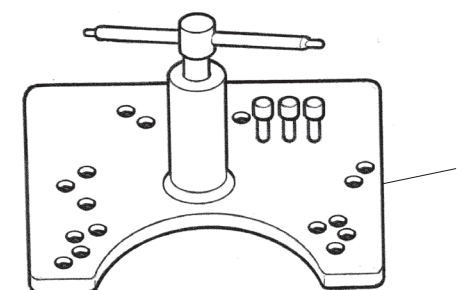
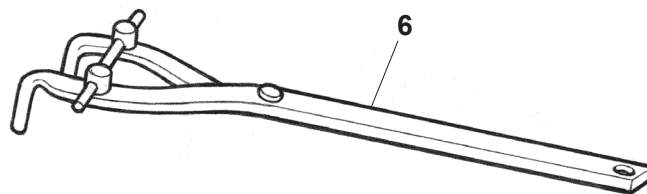
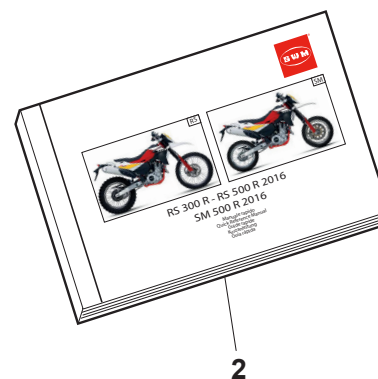
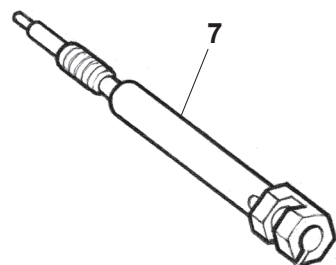
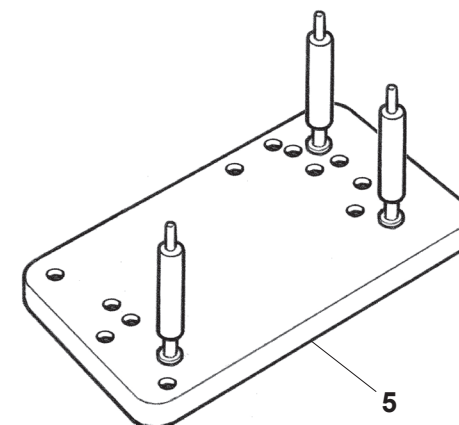
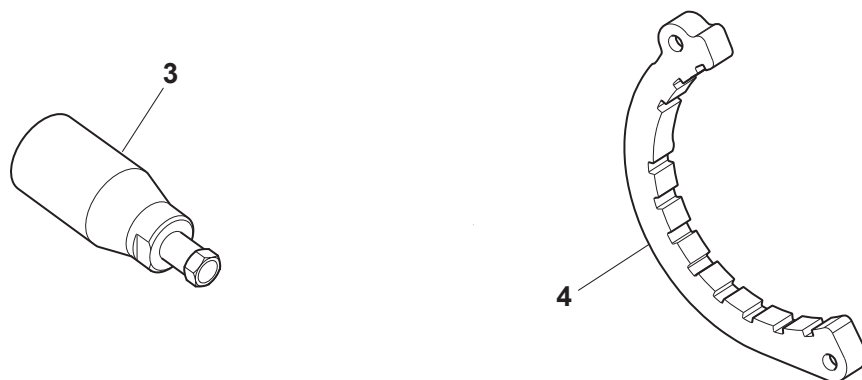

Note Notes Notes Marke Notas	Pos. No. Index Pos.	N. Cod. Code No. Nr. Code Code Nr N. Cod.	Q.tà Q.ty Q.te M.ge C.ad	DENOMINAZIONE	NAME	DESIGNATION	BESHREIBUNG	DENOMINACION
	1	151794702	1	ESTRATTORE CARTER MOTORE	PULLER, CRANKCASE	EXTRACTEUR CARTER MOTEUR	AUSZIEHER, KURBELGEHAUSE	EXTRACTOR CARTER MOTOR
	2	A000P00747	1	MANUALE RAPIDO	QUICK MANUAL	GUIDE RAPIDE	KURZANLEITUNG	GUIA RAPIDA
	3	M000P00835	1	ESTRATTORE VOLANO	FLYWHEEL PULLER	EXTRACTEUR VOLANT MAGNETIQUE	AUSZIEHER, SCHWUNGRAD	EXTRACTOR VOLANTE
	4	M000P00687	1	ATTREZZO FERMO VOLANO P.M.S.	TOOL GENERATOR T.D.C.	OUTIL BLOCAGE VOLANT P.M.H.	WERKZEUG-GENERATOR O.T.	LLAVE BLOQUEO VOLANTE P.M.S.
	5	8A0090662	1	SUPPORTO PER MONTAGGIO MOTORE	SUPPORT ASSY	SUPPORT COMPL.	HALTER	SOPORTE
	6	800079015	1	ATTREZZO BLOCCAGGIO FRIZIONE	WRENCH, CLUTCH HUB RETAINING	OUTIL VERROULAGE EMBRAYAGE	SCHLUSSEL KUPPLUNGSNABE	HERRAMIENTA MONTAJE EMBRAGUE
	7	8000A1625	1	ATTREZZO PORTACOMPARATORE	DIAL GAUGE HOLDING TOOL	OUTIL SUPPORT COMPARETEUR	WERKZEUG MESSUHRHALTER	HERRAMIENTA PORTA RELOJ COMPARADOR

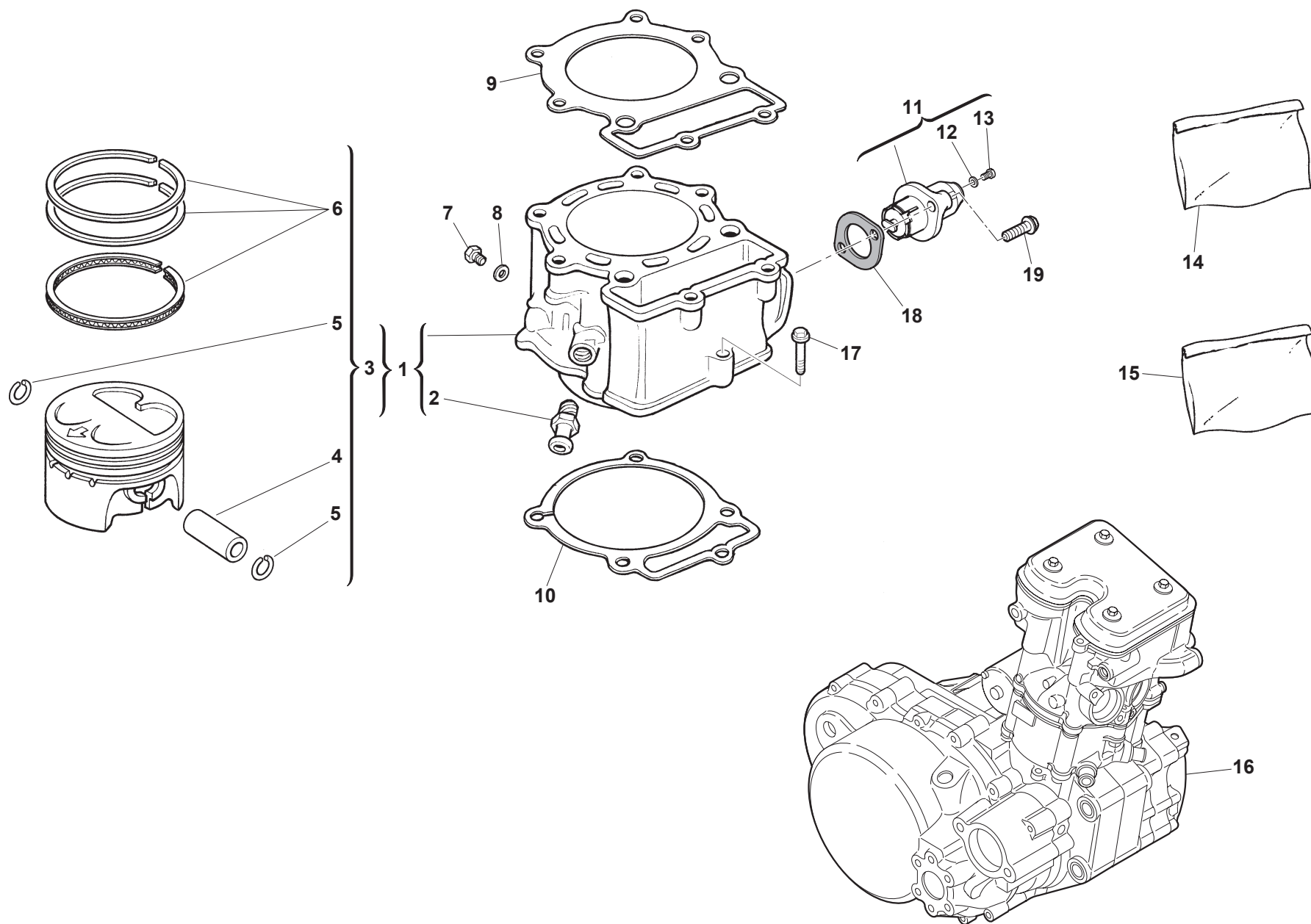



RS 300R/2016
RS 500R/2016
SM 500R/2016

CILINDRO, PISTONE - CYLINDER, PISTON
CYLINDRE, PISTON- ZYLINDER, KOLBEN
CILINDRO, PISTON

TAVOLA
DRAWING
TABLE
BILD
TABLA

2

Note Notes Notes Marke Notas	Pos. No. N. Index Pos.	N. Cod. Code No. Nr. Code Code Nr N. Cod.	Q.tà Q.ty Q.te M.ge C.ad	DENOMINAZIONE	NAME	DESIGNATION	BESHREIBUNG	DENOMINACION
	1	M000A00150	1	CILINDRO COMPLETO	CYLINDER ASSY	CYLINDRE COMPLET	ZYLINDER KOMPL	CILINDRO COMPLETO
	1	M000A00151	1	CILINDRO COMPLETO	CYLINDER ASSY	CYLINDRE COMPLET	ZYLINDER KOMPL	CILINDRO COMPLETO
	2	800063885	2	RACCORDO	JOINT	RACCORD	ANSCHLUSS	EMPALME
	3	8000A9228	1	PISTONE COMPLETO 97 mm	PISTON ASSY. 97 mm	PISTON COMPLET 97 mm	KOLBEN KOMPLETT 97 mm	PISTON COMPLETO 97 mm
	3	8000H0507	1	PISTONE COMPLETO 83 mm	PISTON ASSY. 83 mm	PISTON COMPLET 83 mm	KOLBEN, KPL. 83 mm	PISTON COMPLETO 83 mm
	4	8000A0854	1	SPINOTTO PISTONE	PIN, PISTON	AXE PISTON	KOLBENBOLZEN	BULON PISTON
	4	8000A5459	1	SPINOTTO PISTONE	PIN, PISTON	AXE PISTON	KOLBENBOLZEN	BULON PISTON
	5	8000A3378	2	ANELLINO FERMA SPINOTTO	CLIP PISTON PIN	ATTACHE AXE PISTON	SICHERUNG, KOLBENBOLZEN	GRAPA, BULON PISTON
	5	8000A5460	2	ANELLINO FERMA SPINOTTO	CLIP PISTON PIN	ATTACHE AXE PISTON	SICHERUNG, KOLBENBOLZEN	GRAPA, BULON PISTON
	6	8000A0855	1	SERIE SEGMENTI	PISTON RING SET	JEU SEGMENT PISTON	KOLBENRING SATZ	JUEGO ARO PISTON
	6	8000H0510	1	SERIE SEGMENTI	PISTON RING SET	JEU SEGMENT PISTON	KOLBENRING SATZ	JUEGO ARO PISTON
	7	ZS0067545	1	VITE TEF M6X1X8 CH8	SCREW TEF M6X1X8 CH8	VIS TEF M6X1X8 CH8	SCHRAUBE TEF M6X1X8 CH8	TORNILLO TEF M6X1X8 CH8
	8	8A0015960	1	GUARNIZIONE 10X6,2X1	GASKET 10X6,2X1	JOINT 10X6,2X1	DICHTUNG 10X6,2X1	JUNTA 10X6,2X1
	9	8000H0504	1	GUARNIZIONE TESTA CILINDRO 0,8 mm	GASKET CYLINDER HEAD 0.8 mm	JOINT CULASSE 0,8 mm	DICHTUNG ZYLINDERKOPF 0,8 mm	JUNTA CULATA 0,8 mm
	9	8A00H0504	1	GUARNIZIONE TESTA CILINDRO 0,7 mm	GASKET CYLINDER HEAD 0.7 mm	JOINT CULASSE 0,7 mm	DICHTUNG ZYLINDERKOPF 0,7 mm	JUNTA CULATA 0,7 mm
	9	8B00H0504	1	GUARNIZIONE TESTA CILINDRO 0,9 mm	GASKET CYLINDER HEAD 0.9 mm	JOINT CULASSE 0,9 mm	DICHTUNG ZYLINDERKOPF 0,9 mm	JUNTA CULATA 0,9 mm
	9	8B00A4195	1	GUARNIZIONE TESTA CILINDRO 1,1 mm	GASKET CYLINDER HEAD 1.1 mm	JOINT CULASSE 1,1 mm	DICHTUNG ZYLINDERKOPF 1,1 mm	JUNTA CULATA 1,1 mm
	9	8E00A4195	1	GUARNIZIONE TESTA CILINDRO 1,0 mm	GASKET CYLINDER HEAD 1.0 mm	JOINT CULASSE 1,0 mm	DICHTUNG ZYLINDERKOPF 1,0 mm	JUNTA CULATA 1,0 mm
	9	8H00A4195	1	GUARNIZIONE TESTA CILINDRO 1,2 mm	GASKET CYLINDER HEAD 1.2 mm	JOINT CULASSE 1,2 mm	DICHTUNG ZYLINDERKOPF 1,2 mm	JUNTA CULATA 1,2 mm
	10	800099841	1	GUARNIZIONE BASE CILINDRO	GASKET, CYLINDER BASE	JOINT BASE CYLINDRE	DICHTUNG, ZYLINDER	JUNTA BASE CILINDRO
	11	8000A6950	1	TENDICATENA DISTRIBUZIONE	TENSIONER, TIMING CHAIN	TENDEUR CHAINE DISTRIBUTION	STEUERKETTENSPELLER	TENSIONADOR CADENA DISTRIBUCION
	12	8000A6358	1	RONDELLA	WASHER	RONDELLE	UNTERLEGSCHIEBE	ARANDELA
	13	8000A6357	1	VITE TEF M6X8	SCREW TEF M6X8	VIS TEF M6X8	SCHRAUBE TEF M6X8	TORNILLO TEF M6X8
	14	8000H0503	1	SERIE GUARNIZIONI MOTORE	GASKET SET, ENGINE	JEU JOINT MOTEUR	MOTORDICHTUNGSSATZ	JUEGO JUNTAS MOTOR
	14	8000H0942	1	SERIE GUARNIZIONI MOTORE	GASKET SET, ENGINE	JEU JOINT MOTEUR	MOTORDICHTUNGSSATZ	JUEGO JUNTAS MOTOR
	15	8000B0364	1	SERIE PARAOLIO MOTORE	OIL SEAL SET, ENGINE	JEU BAGUES ETANCHEITE MOTEUR	MOTORWELLENDICHTRINGENSATZ	JUEGO RETENES ACEITE MOTOR
	15	8000B0373	1	SERIE PARAOLIO MOTORE	OIL SEAL SET, ENGINE	JEU BAGUES ETANCHEITE MOTEUR	MOTORWELLENDICHTRINGENSATZ	JUEGO RETENES ACEITE MOTOR
	16	M000A00148	1	MOTORE	ENGINE	MOTEUR	MOTOR	MOTOR
	16	M000A00149	1	MOTORE	ENGINE	MOTEUR	MOTOR	MOTOR
	17	ZE0067545	1	VITE TEF M6X1,00X40 CH8	SCREW TEF M6X1.00X40 CH8	VIS TEF M6X1,00X40 CH8	SCHRAUBE TEF M6X1,00X40 CH8	TORNILLO TEF M6X1,00X40 CH8
	18	8000A6954	1	GUARNIZIONE TENDICATENA DISTRIBUZIONE	GASKET, TENSIONER ADJUSTER	JOINT TENDEUR CHAINE DISTRIBUTION	DICHTUNG STEUERKETTENSPELLER	JUNTA TENSIONADOR CADENA DISTRIBUCION
	19	Z00062728	2	VITE TE M6X1X20 CH8	SCREW TE M6X1X20 CH8	VIS TE M6X1X20 CH8	SCHRAUBE TE M6X1X20 CH8	TORNILLO TE M6X1X20 CH8

A VEDI TAVOLA 9
SEE DRAWING 9
VOIR TABLE 9
SEHEN BILD 9
VER TABLA 9

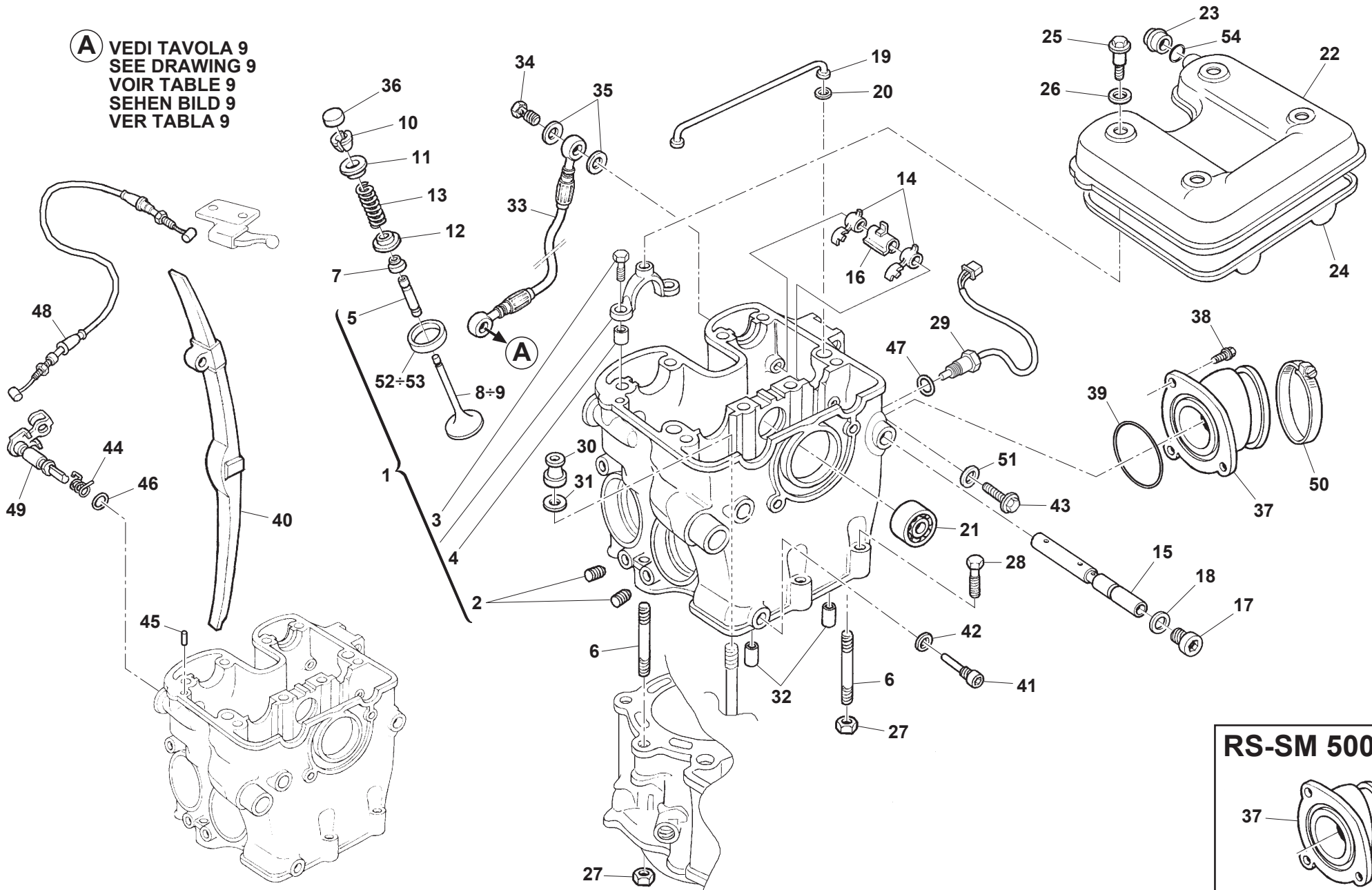

RS-SM 500R

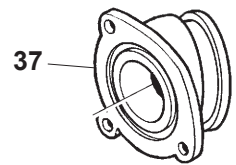



RS 300R/2016
RS 500R/2016
SM 500R/2016

TESTA CILINDRO - CYLINDER HEAD
CULASSE - ZYLINDERKOPF
CULATA

TAVOLA
DRAWING
TABLE
BILD
TABLA

3

Note Notes Marke Notas	Pos. No. N. Index Pos.	N. Cod. Code No. Nr. Code Code Nr N. Cod.	Q.tà Q.ty M.ge C.ad	DENOMINAZIONE	NAME	DESIGNATION	BESHREIBUNG	DENOMINACION
RS 300R	1	8000B0394	1	TESTA CILINDRO	HEAD, CYLINDER	CULASSE	ZYLINDERKOPF	CULATA
RS 500R - SM 500R	1	8000H1474	1	TESTA CILINDRO	HEAD, CYLINDER	CULASSE	ZYLINDERKOPF	CULATA
	2	800049792	4	INSERTO FILETTATO HELI-COIL	THREADED INSERT HELI-COIL	INSERTION FILETE HELI-COIL	GEWINDINSATZ HELI-COIL	ROSCA ROSCADA HELI-COIL
	3	8A0085071	8	VITE TCEI M6X1X25	SCREW TCEI M6X1X25	VIS TCEI M6X1X25	SCHRAUBE TCEI M6X1X25	TORNILLO TCEI M6X1X25
	4	161795501	8	BOCCOLA 8X6,4X6	BUSH 8X6,4X6	DOUILLE 8X6,4X6	BUCHSE 8X6,4X6	CASQUILLO 8X6,4X6
RS 300R	5	8000A4152	4	GUIDAVALVOLA 5 mm	GUIDE-VALVE 5 mm	GUIDE-SOUPAPE 5 mm	VENTILFUEHRUNG 5 mm	GUIA-VALVULA 5 mm
RS 500R - SM 500R	5	8000A4158	2	GUIDAVALVOLA SCARICO 5 mm	GUIDE, EXHAUST VALVE 5 mm	GUIDE-SOUPAPE ECHAPPEMENT 5 mm	AUSLASSVENTILFUEHRUNG 5 mm	GUIA-VALVULA ESCAPE 5 mm
RS 500R - SM 500R	5	8000A4159	2	GUIDAVALVOLA ASPIRAZIONE 5,5 mm	GUIDE INTAKE VALVE 5.5 mm	GUIDE-SOUPAPE D'ASPIRATION 5,5 mm	EINLASSVENTILFUEHRUNG 5,5 mm	GUIA-VALVULA ADMISION 5,5 mm
	6	800074836	2	PRIGIONIERO CILINDRO M8X51mm	STUD BOLT M8X51mm	GOIJON M8X51mm	STIFTSCHRAUBE M8X51mm	ESPARRAGO M8X51mm
RS 500R - SM 500R	7	8000A4136	2	PARAOLIO VALVOLA 5 mm	SEAL VALVE STEM 5 mm	BAGUE D'ETENCHEITE SOUPAPE 5 mm	WELLENDICHRING VENTIL 5 mm	RETEN DE ACEITE VALVULA 5 mm
RS 300R	7	8000A4136	4	PARAOLIO VALVOLA 5 mm	SEAL VALVE STEM 5 mm	BAGUE D'ETENCHEITE SOUPAPE 5 mm	WELLENDICHRING VENTIL 5 mm	RETEN DE ACEITE VALVULA 5 mm
RS 500R - SM 500R	7	8000A4137	2	PARAOLIO VALVOLA 5,5 mm	SEAL VALVE STEM 5.5 mm	BAGUE D'ETENCHEITE SOUPAPE 5,5 mm	WELLENDICHRING VENTIL 5,5 mm	RETEN DE ACEITE VALVULA 5,5 mm
RS 300R	8	8000A5440	2	VALVOLA ASPIRAZIONE TITANIO 5X30,5 mm	VALVE, INTAKE TITANIUM 5X30.5 mm	SOUPAPE ADMISSION TITANE 5X30,5 mm	VENTIL, EINLASS TITAN 5X30,5 mm	VALVULA ADMISION TITANIO 5X30,5 mm
RS 500R - SM 500R	8	8000A5445	2	VALVOLA ASPIRAZIONE TITANIO 5,5X37 mm	VALVE, INTAKE TITANIUM 5.5X37 mm	SOUPAPE ADMISSION TITANE 5,5X37 mm	VENTIL, EINLASS TITAN 5,5X37 mm	VALVULA ADMISION TITANIO 5,5X37 mm
RS 300R	9	8000H0185	2	VALVOLA SCARICO ACCIAIO	VALVE, EXHAUST STEEL	SOUPAPE D'ECHAPPEMENT ACIER	VENTIL, AUSLASS STHAL	VALVULA DE ESCAPE ACERO
RS 500R - SM 500R	9	8000H4194	2	VALVOLA SCARICO ACCIAIO	VALVE, EXHAUST STEEL	SOUPAPE D'ECHAPPEMENT ACIER	VENTIL, AUSLASS STHAL	VALVULA DE ESCAPE ACERO
RS 500R - SM 500R	10	8000A4106	4	SEMICONO VALVOLA 5 mm	COTTER, VALVE 5 mm	DEMI-CLAVETTE SOUPAPE 5 mm	VENTILHALBKEGEL 5 mm	SEMICONO VALVULA 5 mm
RS 300R	10	8000A4106	8	SEMICONO VALVOLA 5 mm	COTTER, VALVE 5 mm	DEMI-CLAVETTE SOUPAPE 5 mm	VENTILHALBKEGEL 5 mm	SEMICONO VALVULA 5 mm
RS 500R - SM 500R	10	8000A4107	4	SEMICONO VALVOLA 5,5 mm	COTTER, VALVE 5.5 mm	DEMI-CLAVETTE SOUPAPE 5,5 mm	VENTILHALBKEGEL 5,5 mm	SEMICONO VALVULA 5,5 mm
RS 500R - SM 500R	11	8000A4151	2	SCODELLINO MOLLA VALVOLA SCARICO 5 mm	RETAINER, EXHAUST VALVE SPRING 5 mm	FIXATION RESSORT SUPAPE ECHAPPEM. 5 mm	TELLER, AUSLASSVENTILFEDER 5 mm	RETEN, RESORTE VALVULA DESCARGA 5 mm
RS 300R	11	8000A4151	4	SCODELLINO MOLLA VALVOLA SCARICO 5 mm	RETAINER, EXHAUST VALVE SPRING 5 mm	FIXATION RESSORT SUPAPE ECHAPPEM. 5 mm	TELLER, AUSLASSVENTILFEDER 5 mm	RETEN, RESORTE VALVULA DESCARGA 5 mm
RS 500R - SM 500R	11	8000A4157	2	SCODELLINO MOLLA VALVOLA ASPIRAZ. 5,5 mm	RETAINER, SPRING INTAKE VALVE 5.5 mm	FIXATION RESSORT SUPAPE ASPIRATION 5,5mm	TELLER, EINLASSVENTILFEDER 5,5 mm	RETEN, RESORTE VALVULA ADMISION 5,5 mm
RS 500R - SM 500R	12	800091578	2	SEDE MOLLA VALVOLA SCARICO	SEAT, SPRING EXHAUST	SIEGE RESSORT DU SOUPAPE ECHAPPEMENT	SITZ, AUSLASSVENTILFEDER	ASIENTO MUELLE VALVULA ESCAPE
RS 300R	12	800091578	4	SEDE MOLLA VALVOLA SCARICO	SEAT, SPRING EXHAUST	SIEGE RESSORT DU SOUPAPE ECHAPPEMENT	SITZ, AUSLASSVENTILFEDER	ASIENTO MUELLE VALVULA ESCAPE
RS 500R - SM 500R	12	8000A4135	2	SEDE MOLLA VALVOLA ASPIRAZIONE	SEAT, SPRING INTAKE	SIEGE RESSORT DU SOUPAPE ADMISSION	SITZ, ENLASS VENTILFEDER	ASIENTO MUELLE VALVULA ADMISION
RS 300R	13	800091579	4	MOLLA VALVOLA	SPRING, VALVE	RESSORT SOUPAPE	VENTILFEDER	MUELLE PARA VALVULA
RS 500R - SM 500R	13	8000A0568	4	MOLLA VALVOLA	SPRING, VALVE	RESSORT SOUPAPE	VENTILFEDER	MUELLE PARA VALVULA
	14	800091568	4	BILANCIERE	ARM ROCKER	CULBUTEUR	KIPPEBEL	BALANCIN
RS 300R	15	8000A5436	2	ASSE BILANCIERE	AXLE, VALVE ROCKER ARM	AXE DU CULBUTEURS	KIPPEBELACHSE	EJE BALANCIN
RS 500R - SM 500R	15	8000A5437	2	ASSE BILANCIERE	AXLE, VALVE ROCKER ARM	AXE CULBUTEURS	KIPPEBELACHSE	EJE BALANCIN
RS 300R	16	8000A5435	1	DISTANZIALE A MOLLA 22,5mm	SPACER, SPRING 22.5mm	ENTRETOISE 22,5mm	ABSTANDHALTER 22,5mm	DISTANCIADOR 22,5mm
RS 300R	16	8A00A5435	1	DISTANZIALE A MOLLA 23,5mm	SPACER, SPRING 23.5mm	ENTRETOISE 23,5mm	ABSTANDHALTER 23,5mm	DISTANCIADOR 23,5mm
RS 500R - SM 500R	16	8B00A5435	1	DISTANZIALE A MOLLA 25,8mm	SPACER, SPRING 25.8mm	ENTRETOISE 25,8mm	ABSTANDHALTER 25,8mm	DISTANCIADOR 25,8mm

A VEDI TAVOLA 9
SEE DRAWING 9
VOIR TABLE 9
SEHEN BILD 9
VER TABLA 9

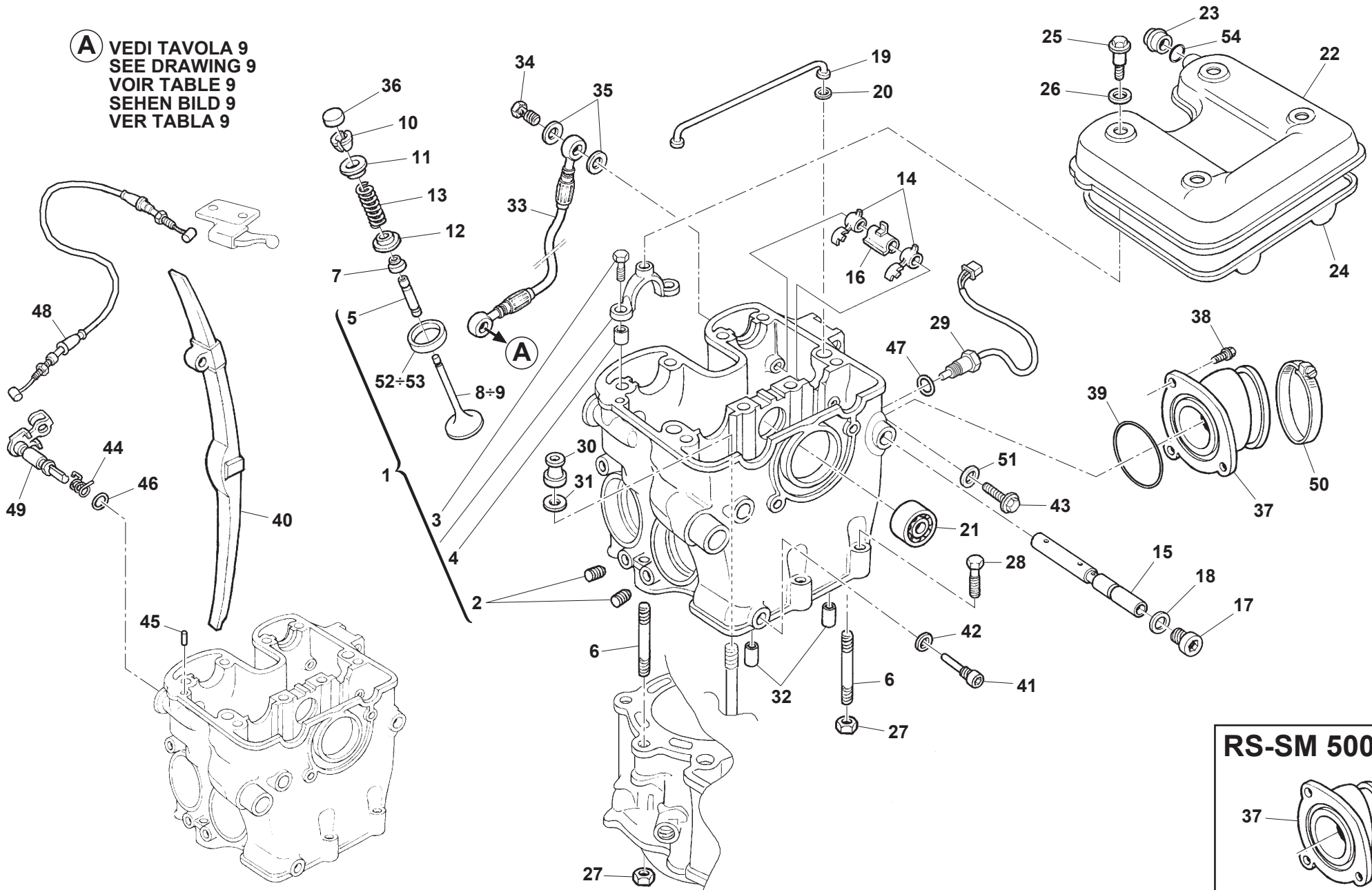

RS-SM 500R

37



RS 300R/2016
RS 500R/2016
SM 500R/2016

TESTA CILINDRO - CYLINDER HEAD
CULASSE - ZYLINDERKOPF
CULATA

TAVOLA
DRAWING
TABLE
BILD
TABLA

3

Note Notes Marke Notas	Pos. No. N. Index Pos.	N. Cod. Code No. Nr. Code Code Nr N. Cod.	Q.tà Q.ty Q.te M.ge C.ad	DENOMINAZIONE	NAME	DESIGNATION	BESHREIBUNG	DENOMINACION
RS 500R - SM 500R	16	8C00A5435	1	DISTANZIALE A MOLLA 30,8mm	SPACER, SPRING 30.8mm	ENTRETOISE 30,8mm	ABSTANDHALTER 30,8mm	DISTANCIADOR 30,8mm
	17	800099711	2	TAPPO DIN 908 M14X1,5	PLUG DIN 908 M14X1.5	BOUCHON DIN 908 M14X1,5	VERSCHLUSS DIN 908 M14X1,5	TAPON DIN 908 M14X1,5
	18	800047763	2	RONDELLA 17,9X14,2X1,5 mm	WASHER 17.9X14.2X1.5 mm	RONDELLE 17,9X14,2X1,5 mm	SCHEIBE 17,9X14,2X1,5 mm	ARANDELA 17,9X14,2X1,5 mm
RS 300R	19	800091583	1	TUBO OLIO	HOSE, OIL	TUYAU HUILE	OELSCHLAUCH	MANGUITO ACEITE
RS 500R - SM 500R	19	800099834	1	TUBO OLIO	HOSE, OIL	TUYAU HUILE	OELSCHLAUCH	MANGUERA ACEITE
	20	800091584	2	ANELLO O-RING 2018 1,78 D4,48	O-RING 2018 1.78 D4.48	JOINT TORIQUE 2018 1,78 D4,48	O-RING 2018 1,78 D4,48	JUNTA TORICA 2018 1,78 D4,48
	21	800034317	1	CUSCINETTO A SFERE 12X28X8	BEARING, BALL 12X28X8	ROULEMENT A BILLES 12X28X8	KUGELLAGER 12X28X8	COJINETE DE BOLAS 12X28X8
RS 500R - SM 500R	22	M000P00098	1	COPERCHIO VALVOLE	COVER, CYLINDER HEAD	COUVERCLE CULASSE	DECKEL, ZYLINDERKOPF	CUBIERTA CULATA
RS 300R	22	M000P00110	1	COPERCHIO VALVOLE	COVER, CYLINDER HEAD	COUVERCLE CULASSE	DECKEL, ZYLINDERKOPF	CUBIERTA CULATA
	23	8000A7039	1	RACCORDO SFIATO	BREATHER PIPE FITTING	RACCORD RENIFLARD	ENTLÜFTUNGSANSCHLUSS	RACOR RESPIRADERO
RS 300R	24	800091566	1	GUARNIZIONE COPERCHIO VALVOLE	GASKET CYLINDER HEAD COVER	JOINT, COUVERCLE CULASSE	DICHTUNG, ZYLINDERKOPFDECKEL	JUNTA CUBIERTA CULATA
RS 500R - SM 500R	24	800099837	1	GUARNIZIONE COPERCHIO VALVOLE	GASKET CYLINDER HEAD COVER	JOINT, COUVERCLE CULASSE	DICHTUNG, ZYLINDERKOPFDECKEL	JUNTA CUBIERTA CULATA
	25	Z00091587	4	VITE	SCREW	VIS	SCHRAUBE	TORNILLO
	26	800091588	4	RONDELLA	WASHER	RONDELLE	SCHEIBE	ARANDELA
	27	Z00054700	2	DADO	NUT	ÉCROU	MUTTER	TUERCA
	28	Z00062730	2	VITE TE M6X1X30 CH8	SCREW TE M6X1X30 CH8	VIS TE M6X1X30 CH8	SCHRAUBE TE M6X1X30 CH8	TORNILLO TE M6X1X30 CH8
	28	ZE0067545	1	VITE TEF M6X1,00X40 CH8	SCREW TEF M6X1.00X40 CH8	VIS TEF M6X1,00X40 CH8	SCHRAUBE TEF M6X1,00X40 CH8	TORNILLO TEF M6X1,00X40 CH8
	29	8000H3649	1	SENSORE TEMPERATURA ACQUA	WATER TEMPERATURE SENSOR	CAPTEUR DE TEMPÉRATURE EAU	WASSERTEMPERATURSENSOR	SENSOR TEMPERATURA AGUA
	30	800091589	4	DADO	NUT	ECROU	MUTTER	TUERCA
	31	Z00023374	4	RONDELLA	WASHER	RONDELLE	UNTERLEGSCHIEBE	ARANDELA
	32	8000H0278	4	BOCCOLA	BUSH	DOUILLE	BUCHSE	BUJE
RS 300 R	33	80A0A0232	1	TUBO OLIO	HOSE, OIL	TUYAU HUILE	OELSCHLAUCH	MANGUITO ACEITE
RS-SM 500 R	33	8AA0A0232	1	TUBO OLIO	HOSE, OIL	TUYAU HUILE	OELSCHLAUCH	MANGUERA ACEITE
	34	8A00A0574	2	VITE FORATA	BANJO BOLT	VIS CREUSE	HOHLSCHRAUBE	TORNILLO TALADRADO
	35	800021480	4	RONDELLA	WASHER	RONDELLE	UNTERLEGSCHIEBE	ARANDELA
	36	8000A4162	4	PASTIGLIA VALVOLA 1,60 mm	PAD, VALVE ADJUSTING 1.60 mm	PASTILLE REGLAGE CULBETEUR 1,60 mm	VENTILKAEPFCHEN 1,60 mm	REGISTRO BALANCIN 1,60 mm
	36	8A00A4162	4	PASTIGLIA VALVOLA 1,65 mm	PAD, VALVE ADJUSTING 1.65 mm	PASTILLE REGLAGE CULBETEUR 1,65 mm	VENTILKAEPFCHEN 1,65 mm	REGISTRO BALANCIN 1,65 mm
	36	8B00A4162	4	PASTIGLIA VALVOLA 1,70 mm	PAD, VALVE ADJUSTING 1.70 mm	PASTILLE REGLAGE CULBETEUR 1,70 mm	VENTILKAEPFCHEN 1,70 mm	REGISTRO BALANCIN 1,70 mm
	36	8C00A4162	4	PASTIGLIA VALVOLA 1,75 mm	PAD, VALVE ADJUSTING 1.75 mm	PASTILLE REGLAGE CULBETEUR 1,75 mm	VENTILKAEPFCHEN 1,75 mm	REGISTRO BALANCIN 1,75 mm
	36	8D00A4162	4	PASTIGLIA VALVOLA 1,80 mm	PAD, VALVE ADJUSTING 1.80 mm	PASTILLE REGLAGE CULBETEUR 1,80 mm	VENTILKAEPFCHEN 1,80 mm	REGISTRO BALANCIN 1,80 mm
	36	8E00A4162	4	PASTIGLIA VALVOLA 1,85 mm	PAD, VALVE ADJUSTING 1.85 mm	PASTILLE REGLAGE CULBETEUR 1,85 mm	VENTILKAEPFCHEN 1,85 mm	REGISTRO BALANCIN 1,85 mm
	36	8F00A4162	4	PASTIGLIA VALVOLA 1,90 mm	PAD, VALVE ADJUSTING 1.90 mm	PASTILLE REGLAGE CULBETEUR 1,90 mm	VENTILKAEPFCHEN 1,90 mm	REGISTRO BALANCIN 1,90 mm
	36	8G00A4162	4	PASTIGLIA VALVOLA 1,95 mm	PAD, VALVE ADJUSTING 1.95 mm	PASTILLE REGLAGE CULBETEUR 1,95 mm	VENTILKAEPFCHEN 1,95 mm	REGISTRO BALANCIN 1,95 mm

A VEDI TAVOLA 9
SEE DRAWING 9
VOIR TABLE 9
SEHEN BILD 9
VER TABLA 9

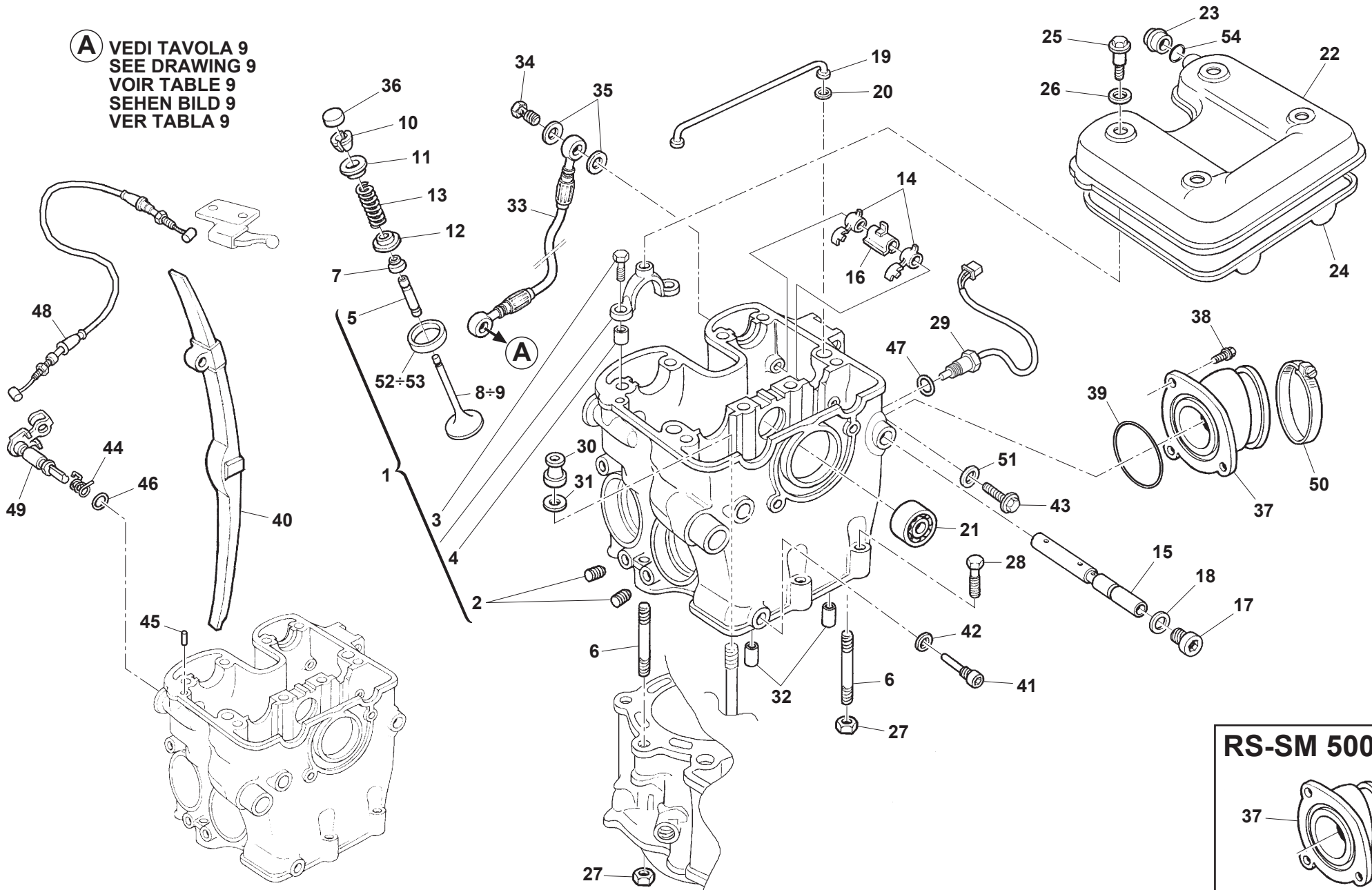

RS-SM 500R



RS 300R/2016
RS 500R/2016
SM 500R/2016

TESTA CILINDRO - CYLINDER HEAD
CULASSE - ZYLINDERKOPF
CULATA

TAVOLA
DRAWING
TABLE
BILD
TABLA

3

Note Notes Notas	Pos. No. Index Pos.	N. Cod. Code No. Nr. Code Code Nr N. Cod.	Q.tà Q.ty Q.te M.ge C.ad	DENOMINAZIONE	NAME	DESIGNATION	BESHREIBUNG	DENOMINACION
	36	8H00A4162	4	PASTIGLIA VALVOLA 2,00 mm	PAD, VALVE ADJUSTING 2.00 mm	PASTILLE REGLAGE CULBETEUR 2,00 mm	VENTILKAEPFCHEN 2,00 mm	REGISTRO BALANCIN 2,00 mm
	36	8J00A4162	4	PASTIGLIA VALVOLA 2,05 mm	PAD, VALVE ADJUSTING 2.05 mm	PASTILLE REGLAGE CULBETEUR 2,05 mm	VENTILKAEPFCHEN 2,05 mm	REGISTRO BALANCIN 2,05 mm
	36	8K00A4162	4	PASTIGLIA VALVOLA 2,10 mm	PAD, VALVE ADJUSTING 2.10 mm	PASTILLE REGLAGE CULBETEUR 2,10 mm	VENTILKAEPFCHEN 2,10 mm	REGISTRO BALANCIN 2,10 mm
	36	8L00A4162	4	PASTIGLIA VALVOLA 2,15 mm	PAD, VALVE ADJUSTING 2.15 mm	PASTILLE REGLAGE CULBETEUR 2,15 mm	VENTILKAEPFCHEN 2,15 mm	REGISTRO BALANCIN 2,15 mm
	36	8M00A4162	4	PASTIGLIA VALVOLA 2,20 mm	PAD, VALVE ADJUSTING 2.20 mm	PASTILLE REGLAGE CULBETEUR 2,20 mm	VENTILKAEPFCHEN 2,20 mm	REGISTRO BALANCIN 2,20 mm
	36	8N00A4162	4	PASTIGLIA VALVOLA 2,25 mm	PAD, VALVE ADJUSTING 2.25 mm	PASTILLE REGLAGE CULBETEUR 2,25 mm	VENTILKAEPFCHEN 2,25 mm	REGISTRO BALANCIN 2,25 mm
	36	8P00A4162	4	PASTIGLIA VALVOLA 2,30 mm	PAD, VALVE ADJUSTING 2.30 mm	PASTILLE REGLAGE CULBETEUR 2,30 mm	VENTILKAEPFCHEN 2,30 mm	REGISTRO BALANCIN 2,30 mm
	36	8R00A4162	4	PASTIGLIA VALVOLA 2,35 mm	PAD, VALVE ADJUSTING 2.35 mm	PASTILLE REGLAGE CULBETEUR 2,35 mm	VENTILKAEPFCHEN 2,35 mm	REGISTRO BALANCIN 2,35 mm
	36	8S00A4162	4	PASTIGLIA VALVOLA 2,40 mm	PAD, VALVE ADJUSTING 2.40 mm	PASTILLE REGLAGE CULBETEUR 2,40 mm	VENTILKAEPFCHEN 2,40 mm	REGISTRO BALANCIN 2,40 mm
	36	8T00A4162	4	PASTIGLIA VALVOLA 2,45 mm	PAD, VALVE ADJUSTING 2.45 mm	PASTILLE REGLAGE CULBETEUR 2,45 mm	VENTILKAEPFCHEN 2,45 mm	REGISTRO BALANCIN 2,45 mm
	36	8U00A4162	4	PASTIGLIA VALVOLA 2,50 mm	PAD, VALVE ADJUSTING 2.50 mm	PASTILLE REGLAGE CULBETEUR 2,50 mm	VENTILKAEPFCHEN 2,50 mm	REGISTRO BALANCIN 2,50 mm
	36	8V00A4162	4	PASTIGLIA VALVOLA 2,55 mm	PAD, VALVE ADJUSTING 2.55 mm	PASTILLE REGLAGE CULBETEUR 2,55 mm	VENTILKAEPFCHEN 2,55 mm	REGISTRO BALANCIN 2,55 mm
	36	8W00A4162	4	PASTIGLIA VALVOLA 2,60 mm	PAD, VALVE ADJUSTING 2.60 mm	PASTILLE REGLAGE CULBETEUR 2,60 mm	VENTILKAEPFCHEN 2,60 mm	REGISTRO BALANCIN 2,60 mm
RS 500R - SM 500R	37	8000B0357	1	COLLETTORE ASPIRAZIONE	MANIFOLD, INTAKE	COLLECTEUR ADMISSION	EINSATZ KRUEMMER	COLECTOR ADMISION
RS 300R	37	8000B0369	1	COLLETTORE ASPIRAZIONE	MANIFOLD, INTAKE	COLLECTEUR ADMISSION	EINSATZ KRUEMMER	COLECTOR ADMISION
	38	60ND02509	3	VITE TCEI M6X1X20 CH5	SCREW TCEI M6X1X20 CH5	VIS TCEI M6X1X20 CH5	SCHRAUBE TCEI M6X1X20 CH5	TORNILLO TCEI M6X1X20 CH5
	39	8A0028553	1	ANELLO O-RING 3200 2,62X50,47	O-RING 3200	JOINT TORIQUE 3200	O-RING 3200	JUNTA TORICA 3200
	40	800091553	1	PATTINO GUIDA CATENA DISTRIBUZIONE	GUIDE, TIMING CHAIN	PATIN GUIDE CHAINE DISTRIBUTION	STEUERKETTENFUEHRUNG	GUIA CADENA DISTRIBUCION
	41	161535902	1	VITE	SCREW	VIS	SCHRAUBE	TORNILLO
	42	800045194	1	RONDELLA 14X8,2X1	WASHER 14X8.2X1	RONDELLE 14X8,2X1	SCHEIBE 14X8,2X1	ARANDELA 14X8,2X1
	43	ZD0067997	1	VITE TE M5X0,8X8	SCREW TE M5X0.8X8	VIS TE M5X0,8X8	SCHRAUBE TE M5X0,8X8	TORNILLO TE M5X0,8X8
	44	800099687	1	MOLLA ALZAVOLVOLE	SPRING	RESSORT	FEDER	MUELLE
	45	800044298	1	RULLINO CILINDRICO 19,8X4	ROLLER 19.8X4	ROULEAU 19,8X4	ROLLE 19,8X4	RULO 19,8X4
	46	800023107	1	ANELLO O-RING 8,73-1,78	O-RING 8.73-1.78	JOINT TORIQUE 8,73-1,78	O-RING 8,73-1,78	JUNTA TORICA 8,73-1,78
	47	8A0023108	4	ANELLO O-RING 2037 1,78X9,25	O RING 2037 1.78X9.25	JOINT TORIQUE 2037 1,78X9,25	O-RING 2037 1,78X9,25	JUNTA TORICA 2037 1,78X9,25
	48	8000A7777	1	CAVO ALZAVOLVOLE	CABLE, DECOMPRESSION	CABLE DECOMPRESSEUR	DEKOMPRESSIONSSEIL	TRANSMISION DESCOMPRESION
	49	800099684	1	LEVA ALZAVOLVOLE	LEVER, VALVE LIFTER	LEVIER DECOMPRESSEUR	DEKOMPRESSIONS HEBEL	PALANCA DECOMPRESION
	50	8000A7693	1	FASCETTA	CLAMP	COLLIER	KLAMMER	ABRAZADERA
	51	62N015672	1	RONDELLA ALLUMINIO 10X5,1X1 mm	ALUMINIUM WASHER 10X5.1X1 mm	RONDELLE EN ALUMINIUM 10X5,1X1 mm	ALUMINIUM SCHEIBE 10X5,1X1 mm	ARANDELA DE ALUMINIO 10X5,1X1 mm
RS 300R	52	8000A5447	2	SEDE VALVOLA ASPIRAZIONE	INTAKE VALVE SEAT	LOGEMENT SOUPEPE D'ADMISSION	EINLASSVENTILSITZ	ASIENTO VÁLVULA ADMISIÓN
RS 500R - SM 500R	52	8000A5450	2	SEDE VALVOLA ASPIRAZIONE	INTAKE VALVE SEAT	LOGEMENT SOUPEPE D'ADMISSION	EINLASSVENTILSITZ	ASIENTO VÁLVULA ADMISIÓN
RS 300R	53	8000A5446	2	SEDE VALVOLA SCARICO	OUTLET VALVE SEAT	LOGEMENT SOUPEPE D'ÉCHAPPEMENT	AUSLASSVENTILSITZ	ASIENTO VÁLVULA ESCAPE
RS 500R - SM 500R	53	8000A5449	2	SEDE VALVOLA SCARICO	OUTLET VALVE SEAT	LOGEMENT SOUPEPE D'ÉCHAPPEMENT	AUSLASSVENTILSITZ	ASIENTO VÁLVULA ESCAPE

A VEDI TAVOLA 9
SEE DRAWING 9
VOIR TABLE 9
SEHEN BILD 9
VER TABLA 9

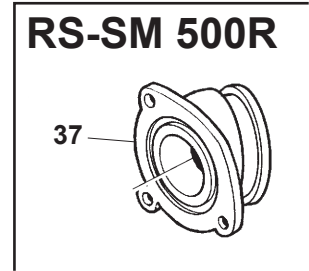
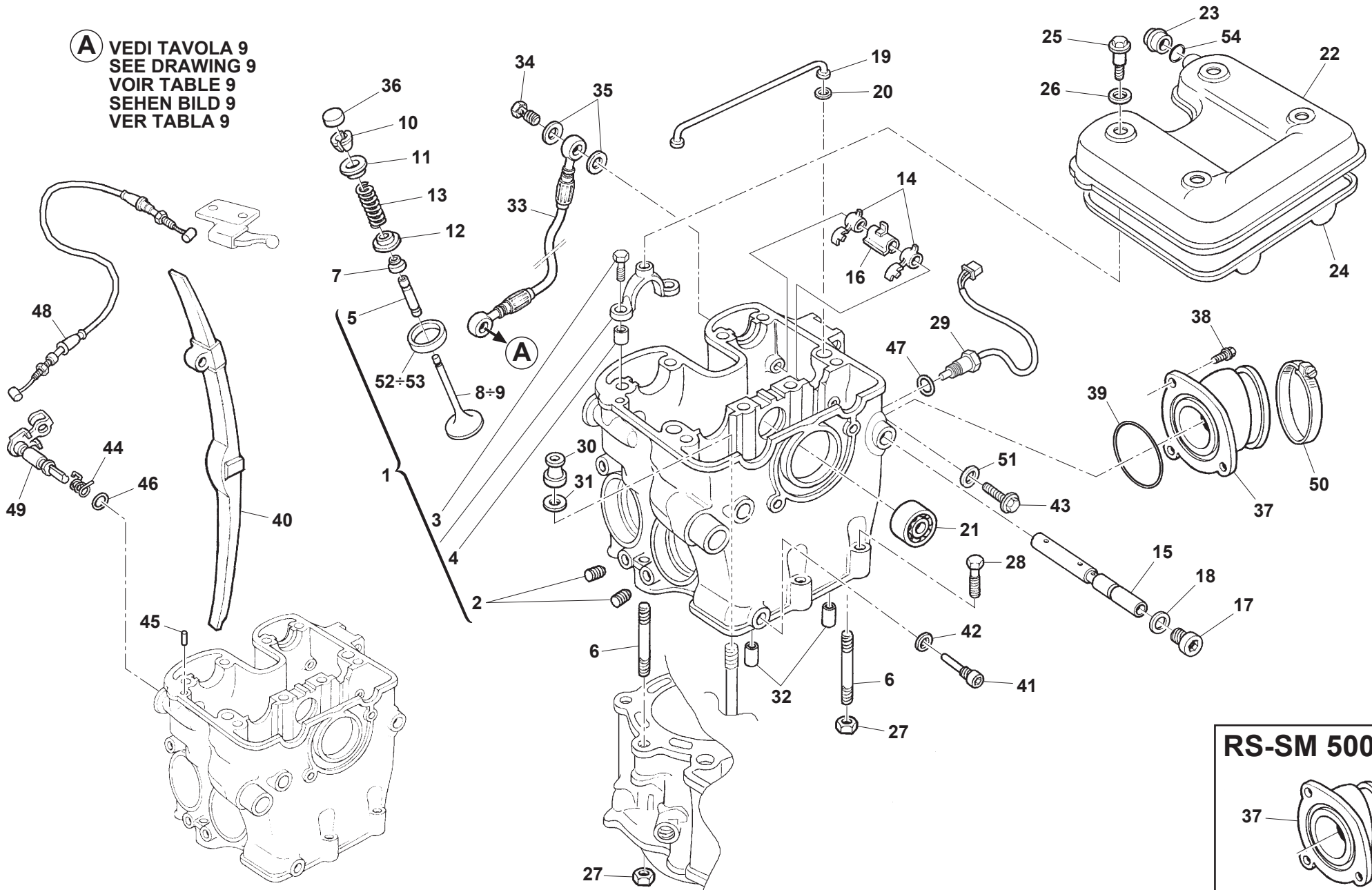

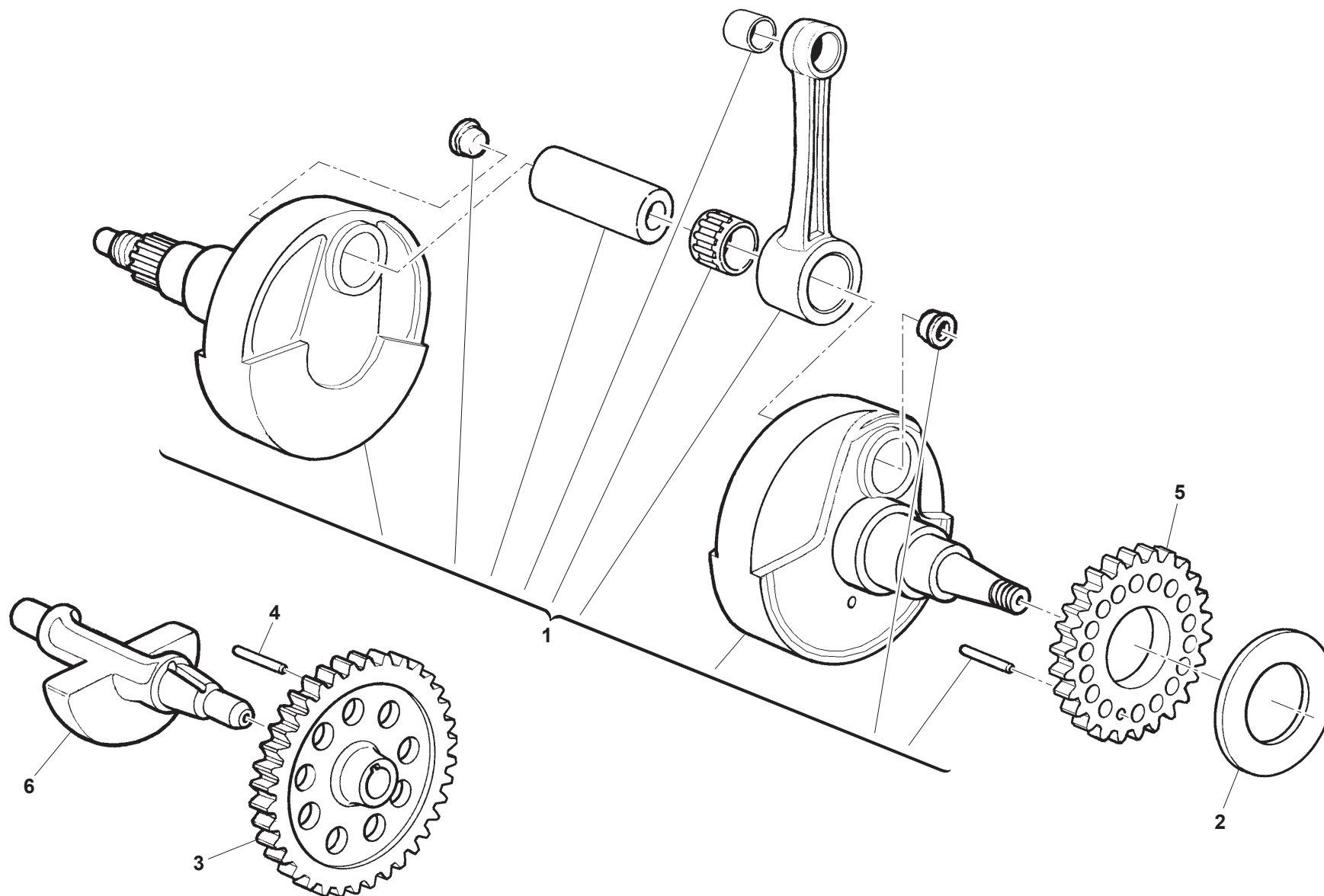

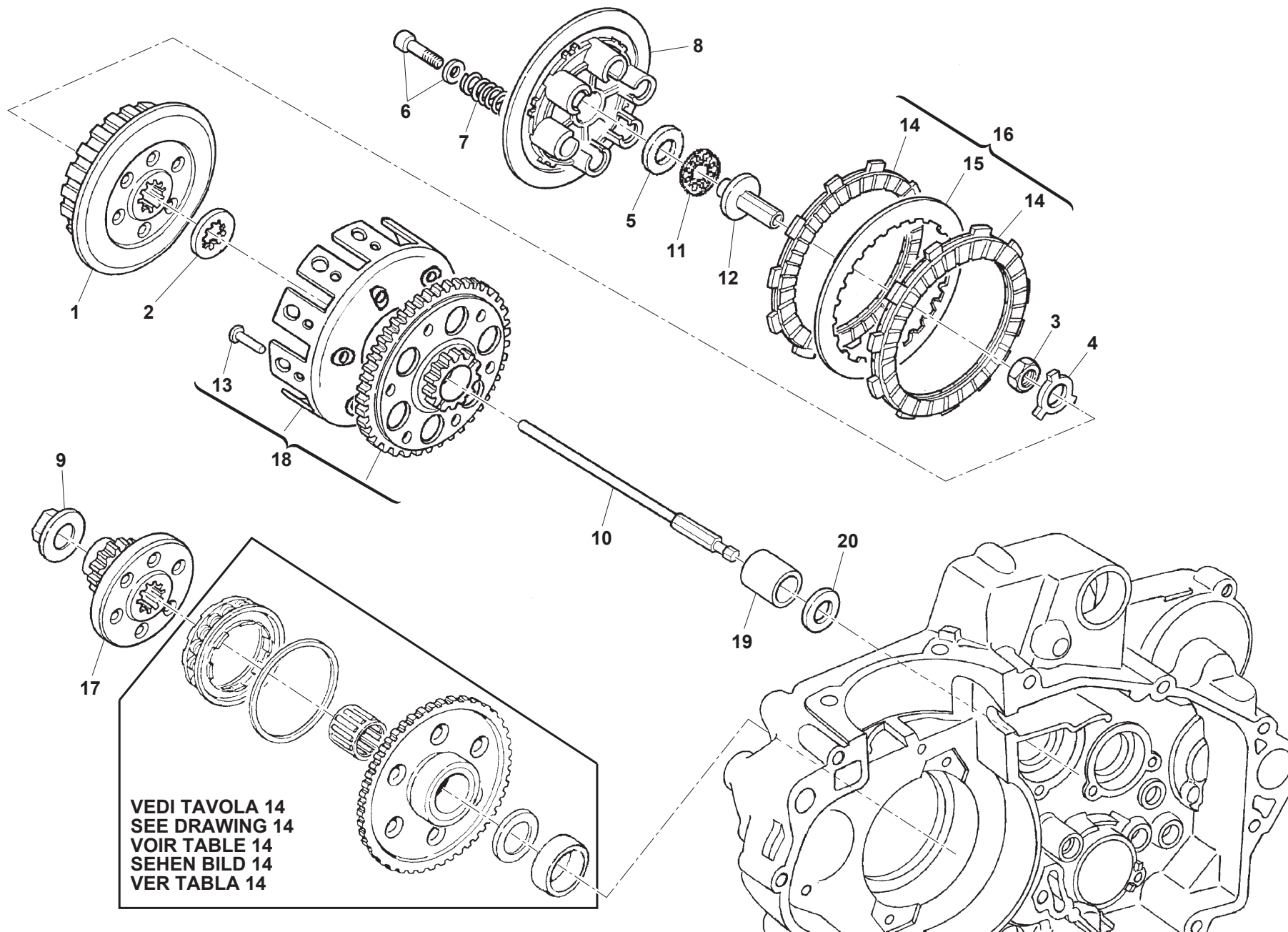

VEDI TAVOLA 14
SEE DRAWING 14
VOIR TABLE 14
SEHEN BILD 14
VER TABLA 14



RS 300R/2016
RS 500R/2016
SM 500R/2016

TRASMISSIONE PRIMARIA, FRIZIONE - PRIMARY DRIVE, CLUTCH
TRANSMISSION PRIMAIRE, EMBRAYAGE
PRIMÄRÜBERSETZUNG, KUPPLUNG - TRANSMISION PRIMARIA, EMBRAGUE

TAVOLA
DRAWING
TABLE
BILD
TABLA

5

Note Notes Notes Marke Notas	Pos. No. N. Index Pos.	N. Cod. Code No. Nr. Code Code Nr N. Cod.	Q.tà Q.ty Q.te M.ge C.ad	DENOMINAZIONE	NAME	DESIGNATION	BESHREIBUNG	DENOMINACION
	1	800085390	1	MOZZETTO FRIZIONE	BOSS, CLUTCH	MOYEU EMBRAYAGE PORTE-DISQUE	KUPPLUNGSSCHEIBENHALTERNABE	CUBO EMBRAGUE PORTA-DISCOS
	2	800038350	1	RONDELLA 46X22X19	WASHER 46X22X19	RONDELLE 46X22X19	SCHEIBE 46X22X19	ARANDELA 46X22X19
	3	800036856	1	DADO M18X1	NUT M18X1	ECROU M18X1	MUTTER M18X1	TUERCA M18X1
	4	800036857	1	RONDELLA DI SICUREZZA 18mm	WASHER, LOCK 18mm	RONDELLE VERROULAGE 18mm	SICHERUNGSSCHEIBE 18mm	ARANDELA CIERRE 18mm
	5	800035781	1	RALLA CUSCINETTO ASSIALE	WASHER, AXIAL BERING	RONDELLE ROULEMENT BUTEE	SCHEIBE DRUCKLAGER	ARANDELA COJINETE EMPUJADOR
	6	M000P00464	6	VITE CON ROSETTA	SCREW WITH WASHER	VIS AVEC RONDELLE	SCHRAUBE MIT SCHEIBE	TORNILLO CON ARANDELA
	7	8000A0730	6	MOLLA FRIZIONE	SPRING, CLUTCH	RESSORT EMBRAYAGE	KUPPLUNGSFEDER	MUELLE EMBRAGUE
	8	800048138	1	PIATTO SPINGIDISCHI FRIZIONE	DISC, CLUTCH PRESSURE	DISQUE POUSSEE EMBRAYAGE	ANDRUECKTELLER KUPPLUNGSSCHEIBE	EMPUJADOR DISCO EMBRAGUE
	9	Y00099933	1	DADO FLANGIATO M18X1,25	NUT FLANGE M18X1.25	ECROU BRIDE M18X1.25	GEFLANSCHTE MUTTER M18X1,25	TUERCA CON REBORDE M18X1,25
	10	8A00B0497	1	ASTA SPINGIFRIZIONE	ROD-PUSH, CLUTCH	TIGE POUSSEE EMBRAYAGE	KUPPLUNGSGESTAENGE	VARILLA EMPUJE DISCO EMBRAGUE
	11	800035780	1	CUSCINETTO ASSIALE REGGISPINTA	BEARING, THRUST	ROULEMENT BUTEE	DRUCKLAGER	COJINETE EMPUJADOR
	12	8000A9749	1	PUNTALINO FRIZIONE	PIECE, CLUTCH PUSH	BARRE PRESSION	DRUCKSTANGE	PISTON BOMBIN EMBRAGUE
RS 500R - SM 500R	13	800048236	8	RIBATTINO TSP 5X22 UNI 752	RIVET TSP 5X22 UNI 752	RIVET TSP 5X22 UNI 752	NIET TSP 5X22 UNI 752	REMACHE TSP 5X22 UNI 752
	14	8000A6916	8	DISCO FRIZIONE CONDUTTORE	PLATE, CLUTCH	DISQUE EMBRAYAGE MENANT	TREIBENDE KUPPLUNGSSCHEIBE	DISCO EMBRAGUE CONDUCTOR
	15	800048138	7	DISCO FRIZIONE CONDOTTO	PLATE, CLUTCH DRIVEN	DISQUE EMBRAYAGE ENTRAINE	ANGETRIEBENES KUPPLUNGSSCHEIBE	DISCO EMBRAGUE ACCIONADO
	16	8000A9764	1	SERIE DISCHI FRIZIONE	CLUTCH DISC SET	JEU DISQUES EMBRAYAGE	KUPPLUNGSSCHEIBENSATZ	JUEGO DISCOS EMBRAGUE
RS 500R - SM 500R	17	8000A5921	1	INGRANAGGIO CONDUTTORE Z23	GEAR, DRIVE T23	ENGRENAGE MENANT D23	TREIBENDES ZAHNRAD Z23	ENGRANAJE CONDUCTOR D23
RS 300R	17	M000A00210	1	INGRANAGGIO CONDUTTORE Z24	GEAR, DRIVE T24	ENGRENAGE MENANT D24	TREIBENDES ZAHNRAD Z24	ENGRANAJE CONDUCTOR D24
RS 500R - SM 500R	18	8000A9202	1	CAMPANA FRIZIONE	CLUTCH HOUSING	CLOCHE EMBRAYAGE	KUPPLUNGSKASTEN	CAMPANA EMBRAGUE
RS 300R	18	M000A00088	1	CAMPANA FRIZIONE	CLUTCH HOUSING	CLOCHE EMBRAYAGE	KUPPLUNGSKASTEN	CAMPANA EMBRAGUE
	19	161538801	1	BOCCOLA	BUSH	DOUILLE	BUCHSE	BUJE
	20	8E0030053	1	RONDELLA RASAMENTO 38X25,2	THRUST WASHER 38X25.2	RONDELLE DE BUTEE 38X25,2	DISTANZSCHEIBE 38X25,2	ARANDELA DE SEPARACION 38X25,2

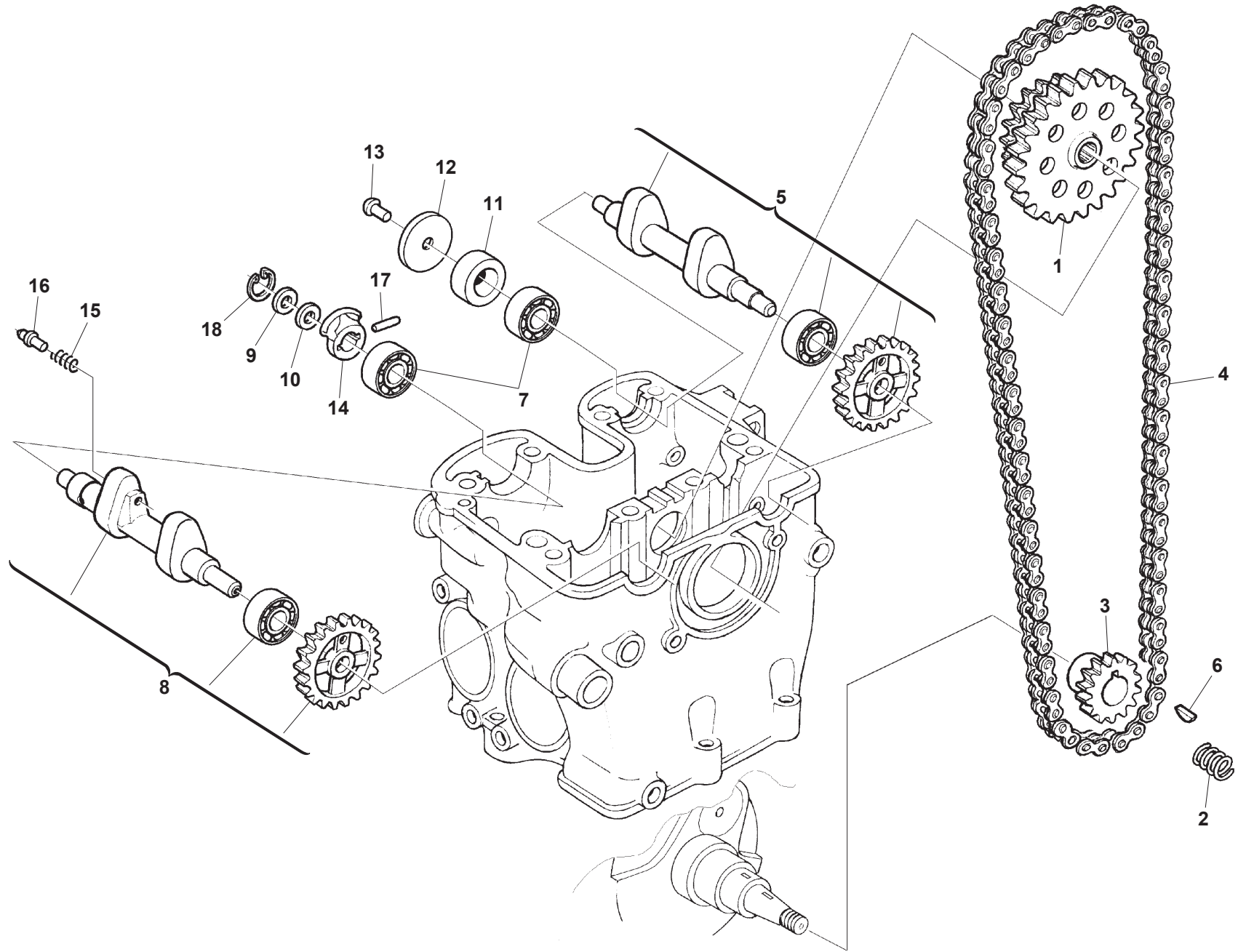



RS 300R/2016
RS 500R/2016
SM 500R/2016

DISTRIBUZIONE - VALVE TIMING
DISTRIBUTION - VENTILSTEUERUNG
DISTRIBUCION

TAVOLA
 DRAWING
 TABLE
 BILD
 TABLA

6

Note Notes Notes Marke Notas	Pos. No. N. Index Pos.	N. Cod. Code No. Nr. Code Code Nr N. Cod.	Q.tà Q.ty Q.te M.ge C.ad	DENOMINAZIONE	NAME	DESIGNATION	BESHREIBUNG	DENOMINACION
RS 500R - SM 500R	1	8000A4790	1	INGRANAGGIO RINVIO DISTRIBUZIONE Z36/34	GEAR, TIMING T36/34	ENGRANAGE DISTRIBUTION D36/34	STEUERZAHNRAD Z36/34	ENGRANAJE DISTRIBUCCION D36/34
RS 300R	1	8000A4791	1	INGRANAGGIO RINVIO DISTRIBUZIONE Z33/34	GEAR, TIMING T33/34	ENGRANAGE DISTRIBUTION D33/34	STEUERZAHNRAD Z33/34	ENGRANAJE DISTRIBUCCION D33/34
	2	800061275	1	MOLLA	SPRING	RESSORT	FEDER	MUELLE
	3	8C0063811	1	INGRANAGGIO DISTRIBUZIONE Z17	TIMING GEAR T17	PIGNON DISTRIBUTION D17	STEUERZAHNRAD Z17	ENGRANAJE DISTRIBUCCION D17
RS 500R - SM 500R	4	8B0035794	1	CATENA DISTRIBUZIONE	CHAIN, TIMING	CHAINE DISTRIBUTION	STEUERKETTE	CADENA DISTRIBUCION
RS 300R	4	8F0035794	1	CATENA DISTRIBUZIONE	CHAIN, TIMING	CHAINE DISTRIBUTION	STEUERKETTE	CADENA DISTRIBUCION
RS 300R	5	8000A5592	1	ALBERO A CAMME ASPIRAZIONE	CAM SHAFT, INTAKE	ARBRE A CAMES ASPIRATION	ENLASS NOCKENWELLE	ARBOL LEVAS ADMISION
RS 500R - SM 500R	5	8000A5595	1	ALBERO A CAMME ASPIRAZIONE	CAM SHAFT, INTAKE	ARBRE A CAMES ASPIRATION	ENLASS NOCKENWELLE	ARBOL LEVAS ADMISION
	6	161509801	1	CHIAVETTA WOODRUFF	KEY, WOODRUFF	CLAVETTE, DEMI-LUNE WOODRUFF	EINLEGE KEIL, WOODRUFF	CHAVETA WOODRUFF
	7	800034317	2	CUSCINETTO A SFERE 12X28X8	BEARING, BALL 12X28X8	ROULEMENT A BILLES 12X28X8	KUGELLAGER 12X28X8	COJINETE DE BOLAS 12X28X8
RS 300R	8	800099694	1	ALBERO A CAMME SCARICO	CAM SHAFT, EXHAUST	ARBRE A CAMES ECHAPPEMENT	AUSLASS NOCKENWELLE	ARBOL LEVAS ESCAPE
RS 500R - SM 500R	8	8000A4953	1	ALBERO A CAMME SCARICO	CAM SHAFT, EXHAUST	ARBRE A CAMES ECHAPPEMENT	AUSLASS NOCKENWELLE	ARBOL LEVAS ESCAPE
	9	8A00H0597	1	RONDELLA RASAMENTO 16X19,2 X0,8	WASHER. THRUST 16X19,2 X0,8	RONDELLE DE BUTEE 16X19,2 X0,8	DISTANZSCHEIBE 16X19,2 X0,8	ARANDELA DE SEPARACION 16X19,2 X0,8
	10	8000H0597	1	RONDELLA RASAMENTO 16X19,2X1	WASHER. THRUST 16X19,2X1	RONDELLE DE BUTEE 16X19,2X1	DISTANZSCHEIBE 16X19,2X1	ARANDELA DE SEPARACION 16X19,2X1
	11	8000A6271	1	DISTANZIALE	SPACER	ENTRETOISE	ABSTANDHALTER	DISTANCIADOR
	12	800099703	1	DISCO CENTRIFUGO	CENTRIFUGAL DISC	DISQUE CENTRIFUGE	SCHEIBE	DISCO CENTRIFUGO
	13	Z00055699	1	VITE TCEI M6X1X10	SCREW TCEI M6X1X10	VIS TCEI M6X1X10	SCHRAUBE TCEI M6X1X10	TORNILLO TCEI M6X1X10
RS 500R - SM 500R	14	8000A8994	1	MASSA ALZAVALVOLA	WEIGHT, VALVE LIFTER	MASSELOTTE DECOMPRESSEUR	GEWICHT, DEKOMPRESSION	MASA DECOMPRESION
RS 300R	14	8000A9450	1	MASSA ALZAVALVOLA	WEIGHT, VALVE LIFTER	MASSELOTTE DECOMPRESSEUR	GEWICHT, DEKOMPRESSION	MASA DECOMPRESION
	15	800099699	1	MOLLA	SPRING	RESSORT	FEDER	MUELLE
	16	800099700	1	PERNO	PIN	PIVOT	BOLZEN	PERNO
	17	800099701	1	RULLINO B4X21,8	ROLLER B4X21,8	ROULEAU B4X21,8	ROLLE B4X21,8	RULO B4X21,8
	18	66N021205	1	ANELLO SEEGER 16 mm	CIRCLIP 16 mm	CIRCLIP 16 mm	SEEGERRING 16 mm	ANILLO SEEGER 16 mm

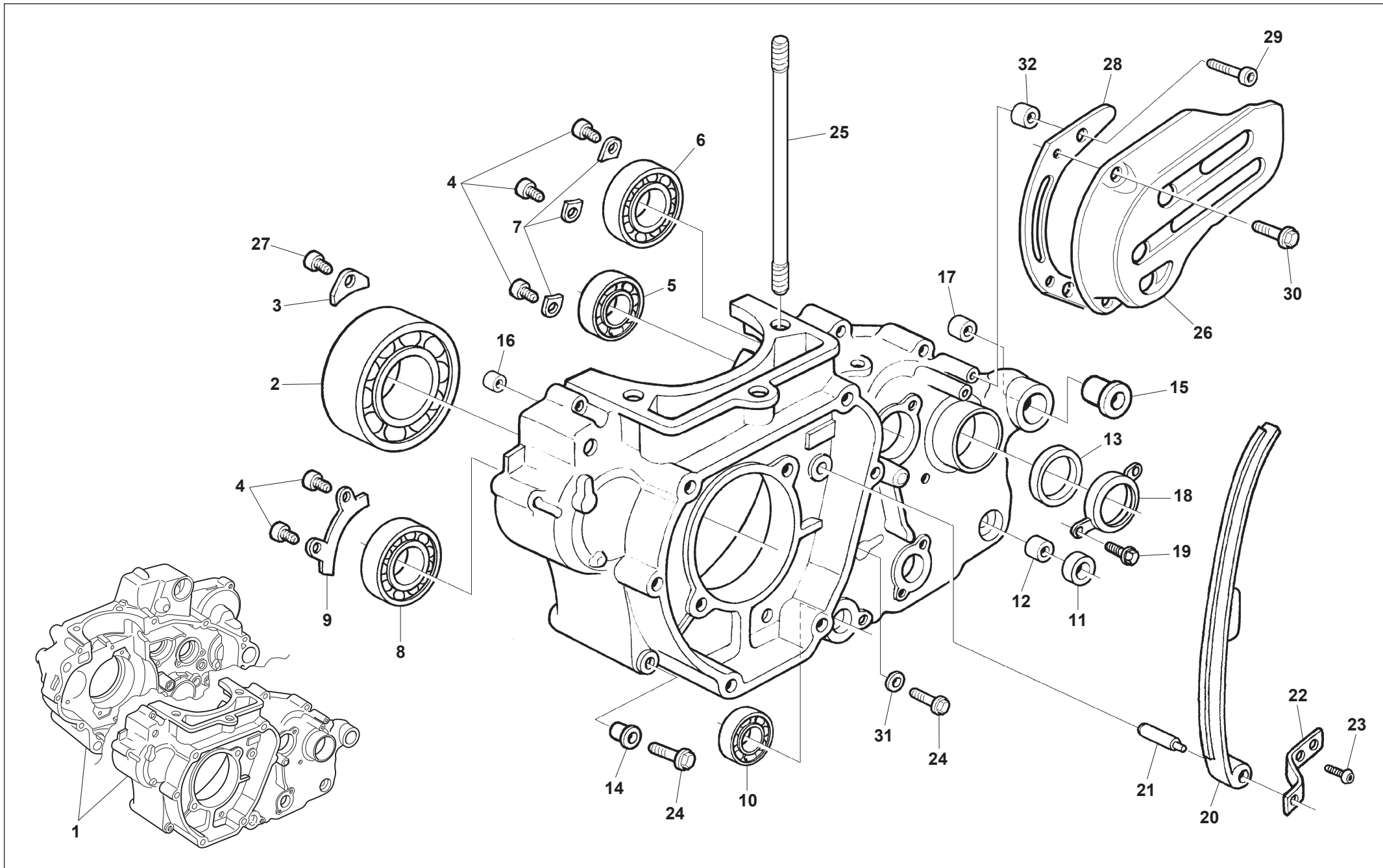



RS 300R/2016
RS 500R/2016
SM 500R/2016

SEMICARTER SINISTRO - L.H. HALF CRANKCASE
CARTER G. - GEHAUSEDECKEL L.
BANCADA IZQ.

TAVOLA
DRAWING
TABLE
BILD
TABLA

7

Note Notes Notas	Pos. No. Index Pos.	N. Cod. Code No. Nr. Code Code Nr N. Cod.	Q.tà Q.ty M.ge C.ad	DENOMINAZIONE	NAME	DESIGNATION	BESHREIBUNG	DENOMINACION
	1	8A00A5671	1	CARTER MOTORE	CRANKCASE SET	CARTER MOTEUR	KURBELWELLENGEHAUSE	CARTER MOTOR
	2	800099846	1	CUSCINETTO A SFERE 30X72X19 mm	BALL BEARING 30X72X19 mm	ROULEMENT A BILLES 30X72X19 mm	KUGELLAGER 30X72X19 mm	COJINETE DE BOLAS 30X72X19 mm
	3	800097941	2	PIASTRINA RITEGNO CUSCINETTO	RETAINER, BEARING	PLAQUE ARRET ROULEMENT	STOPPLATTE, LAGER	PLACA RETENCION COJINETE
	4	YA0055241	3	VITE TCEI M6X1,00X14 CH5	SCREW TCEI M6X1.00X14 CH5	VIS TCEI M6X1,00X14 CH5	SCHRAUBE TCEI M6X1,00X14 CH5	TORNILLO TCEI M6X1,00X14 CH5
	5	800099847	1	CUSCINETTO A SFERE 17X40X12	BEARING, DRIVE SHAFT, RH 17X40X12	ROULEMENT A BILLES 17X40X12	KUGELLAGER 17X40X12	COJINETE DE BOLAS 17X40X12
	6	8A0043567	1	CUSCINETTO 25X52X15mm	BEARING 25X52X15mm	ROULEMENT 25X52X15mm	LAGER 25X52X15mm	COJINETE 25X52X15mm
	7	800051746	3	PIASTRINA RITEGNO CUSCINETTO	RETAINER, BEARING	PLAQUE ARRET ROULEMENT	STOPPLATTE, LAGER	PLACA RETENCION COJINETE
	8	8A0019768	1	CUSCINETTO A SFERE	BEARING, BALL	ROULEMENT A BILLES	KUGELLAGER	COJINETE DE BOLAS
	9	800091602	1	PIASTRINA RITEGNO CUSCINETTO	RETAINER, BEARING	PLAQUE ARRET ROULEMENT	STOPPLATTE, LAGER	PLACA RETENCION COJINETE
	10	800065884	1	CUSCINETTO A SFERE 37X25X7	BEARING, RADIAL BALL 37X25X7	ROULEMENT A BILLES 37X25X7	KUGELLAGER 37X25X7	COJINETE DE BOLAS 37X25X7
	11	800034451	1	PARAOLIO 12X19X5	OIL SEAL 12X19X5	BAGUE D'ETANCHEITE 12X19X5	WELLENDICHTRING 12X19X5	RETEN DE ACEITE 12X19X5
	12	8A0065847	1	BOCCOLA	BUSH	DOUILLE	BUCHSE	BUJE
	13	800059977	1	PARAOLIO 32X40X5	SEAL, OIL 32X40X5	BAGUE D'ETANCHEITE 32X40X5	WELLENDICHTRING 32X40X5	RETEN DE ACEITE 32X40X5
	14	161077703	2	BOCCOLA FLANGIATA	BUSH WITH COLLAR	DOUILLE BRIDEE	GEFLANSCHBUCHSE	CASQUILLO REBORDEADO
	15	800073500	1	BOCCOLA FORCELLONE	BUSHING, SWING ARM	DOUILLE, BRAS OSCILLANT	HULSE, SCHWINGE	COLLAR BASCULANTE
	16	161077601	1	BOCCOLA 13X8,5X15	BUSH 13X8.5X15	DOUILLE 13X8,5X15	BUCHSE 13X8,5X15	BUJE 13X8,5X15
	17	161459002	1	BOCCOLA 22X17,5X15	BUSH 22X17.5X15	DOUILLE 22X17,5X15	BUCHSE 22X17,5X15	BUJE 22X17,5X15
	18	800099850	1	PIASTRINA RITEGNO PARAOLIO	PLATE HOLDING OIL SEAL	PLAQUETTE FIXATION JBAGUE ETANCHEITE	HALTEPLATTE WELLENDICHTRING	PLACA SUJECION RETEN ACEITE
	19	Z00067997	2	VITE TEF M5X0,8X12	SCREW TEF M5X0.8X12	VIS TEF M5X0,8X12	SCHRAUBE TEF M5X0,8X12	TORNILLO TEF M5X0,8X12
RS 300R	20	8000H0241	1	PATTINO TENDICATENA DISTRIBUZIONE	TENSIONER, CAM CHAIN	PATIN TENDEUR CHAINE DISTRIBUTION	STEUERKETTENGLEITFUEHRUNG	PATIN TENSOR CADENA DISTRIBUCION
RS 500R - SM 500R	20	8000H0285	1	PATTINO TENDICATENA DISTRIBUZIONE	TENSIONER, CAM CHAIN	PATIN TENDEUR CHAINE DISTRIBUTION	STEUERKETTENGLEITFUEHRUNG	PATIN TENSOR CADENA DISTRIBUCION
	21	800099704	1	PERNO	PIN	PIVOT	BOLZEN	PERNO
	22	800099705	1	PIASTRINA	PLATE	PLAQUETTE	PLAETTCHEN	PLETINA
	23	Z00066774	2	VITE TCIC M4X0,7X8	SCREW TCIC M4X0.7X8	VIS TCIC M4X0,7X8	SCHRAUBE TCIC M4X0,7X8	TORNILLO TCIC M4X0,7X8
	24	Z00062731	12	VITE TEF M6X1X45	SCREW TEF M6X1X45	VIS TEF M6X1X45	SCHRAUBE TEF M6X1X45	TORNILLO TEF M6X1X45
RS 300R	25	8C0081650	2	PRIGIONIERO M10X165 mm	STUD BOLT M10X165 mm	GOUJON M10X165 mm	STIFTSCHRAUBE M10X165 mm	ESPARRAGO M10X165 mm
RS 500R - SM 500R	25	8D0081650	2	PRIGIONIERO M10X193 mm	STUD BOLT M10X193 mm	GOUJON M10X193 mm	STIFTSCHRAUBE M10X193 mm	ESPARRAGO M10X193 mm
	26	80A066973	1	COPERCHIO PIGNONE	COVER, SPROCKET	COUVERCLE PIGNON CHAINE	DECKEL, RITZEL	CUBIERTA PINON CADENA
	27	Y00028327	2	VITE TSEI M6X1,00X14 CH4	SCREW TSEI M6X1.00X14 CH4	VIS TSEI M6X1,00X14 CH4	SCHRAUBE TSEI M6X1,00X14 CH4	TORNILLO TSEI M6X1,00X14 CH4
	28	8000A0663	1	PIASTRA GUIDA CATENA	PLATE, CHAIN GUIDE	PLAQUE GUIDE CHAINE	FUEHRUNGSPLATTE, KETTE	PLACA, GUIA CADENA
	29	YA0055241	2	VITE TCEI M6X1,00X14 CH5	SCREW TCEI M6X1.00X14 CH5	VIS TCEI M6X1,00X14 CH5	SCHRAUBE TCEI M6X1,00X14 CH5	TORNILLO TCEI M6X1,00X14 CH5
	30	Z00062725	2	VITE TEF M6X1,00X10 CH8	SCREW TEF M6X1.00X10 CH8	VIS TEF M6X1,00X10 CH8	SCHRAUBE TEF M6X1,00X10 CH8	TORNILLO TEF M6X1,00X10 CH8
	31	8A0015960	1	GUARNIZIONE 10X6,2X1	GASKET 10X6,2X1	JOINT 10X6,2X1	DICHTUNG 10X6,2X1	JUNTA 10X6,2X1

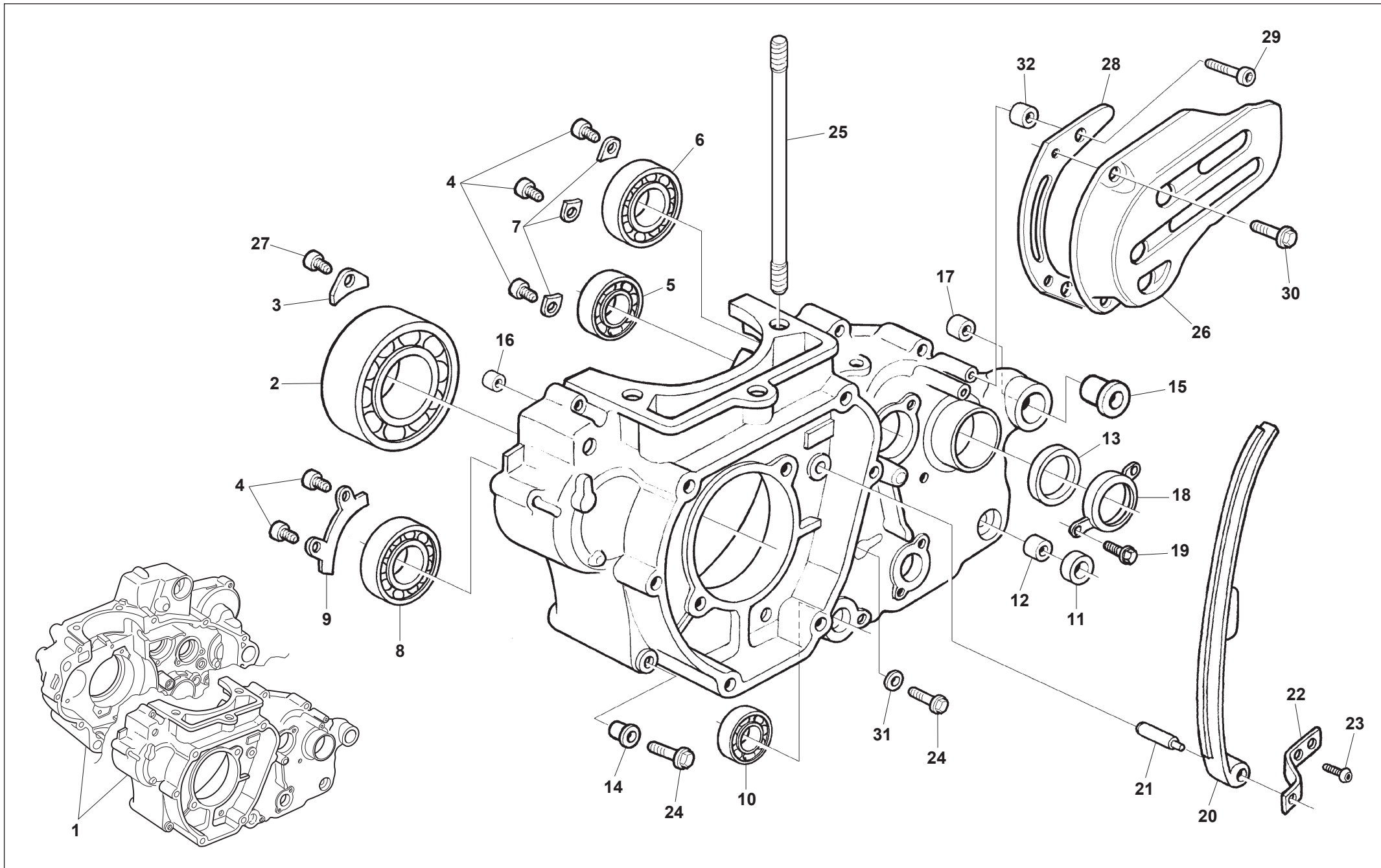

VEDI TAVOLA 11
SEE DRAWING 11
VOIR TABLE 11
SEHEN BILD 11
VER TABLA 11

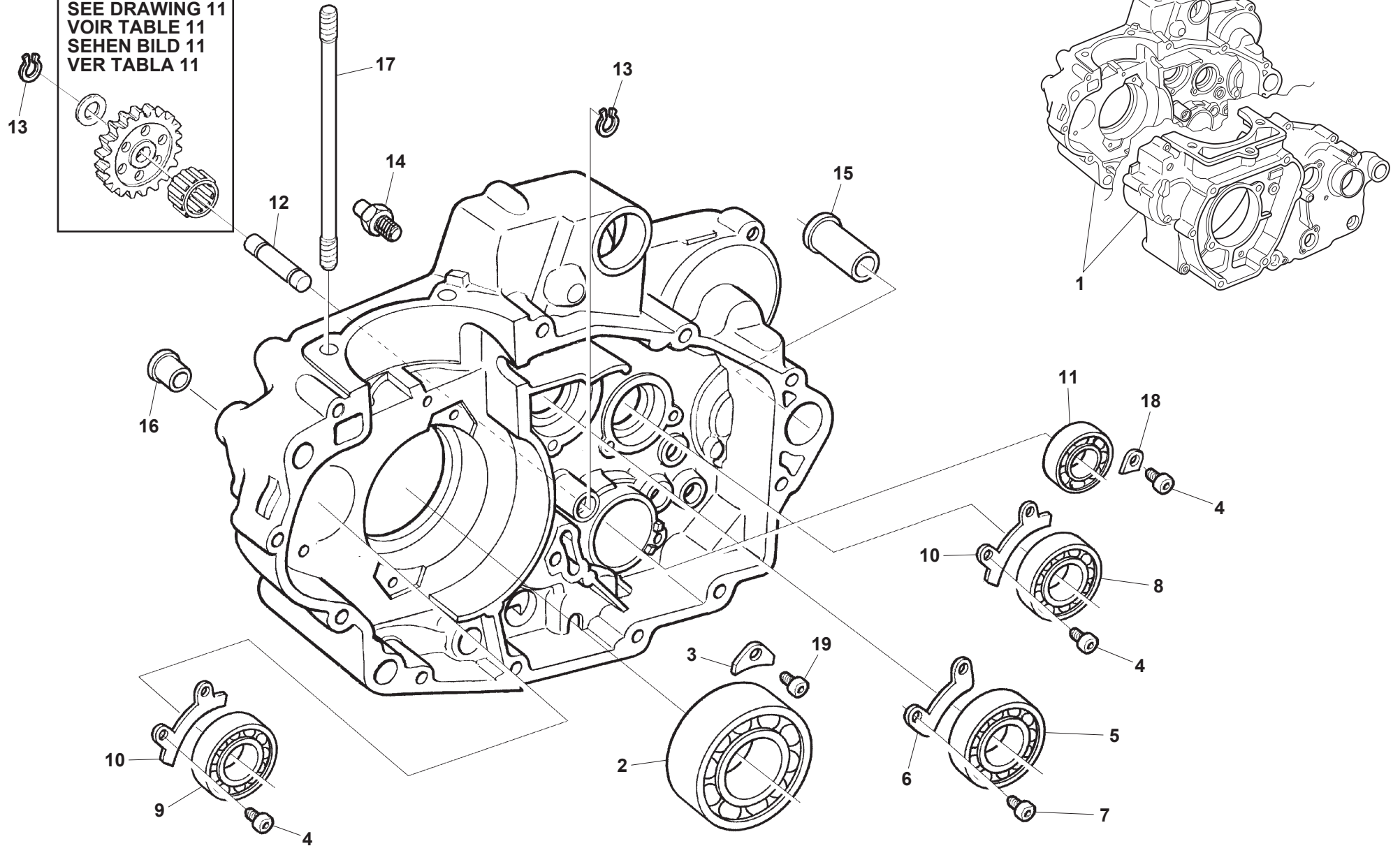

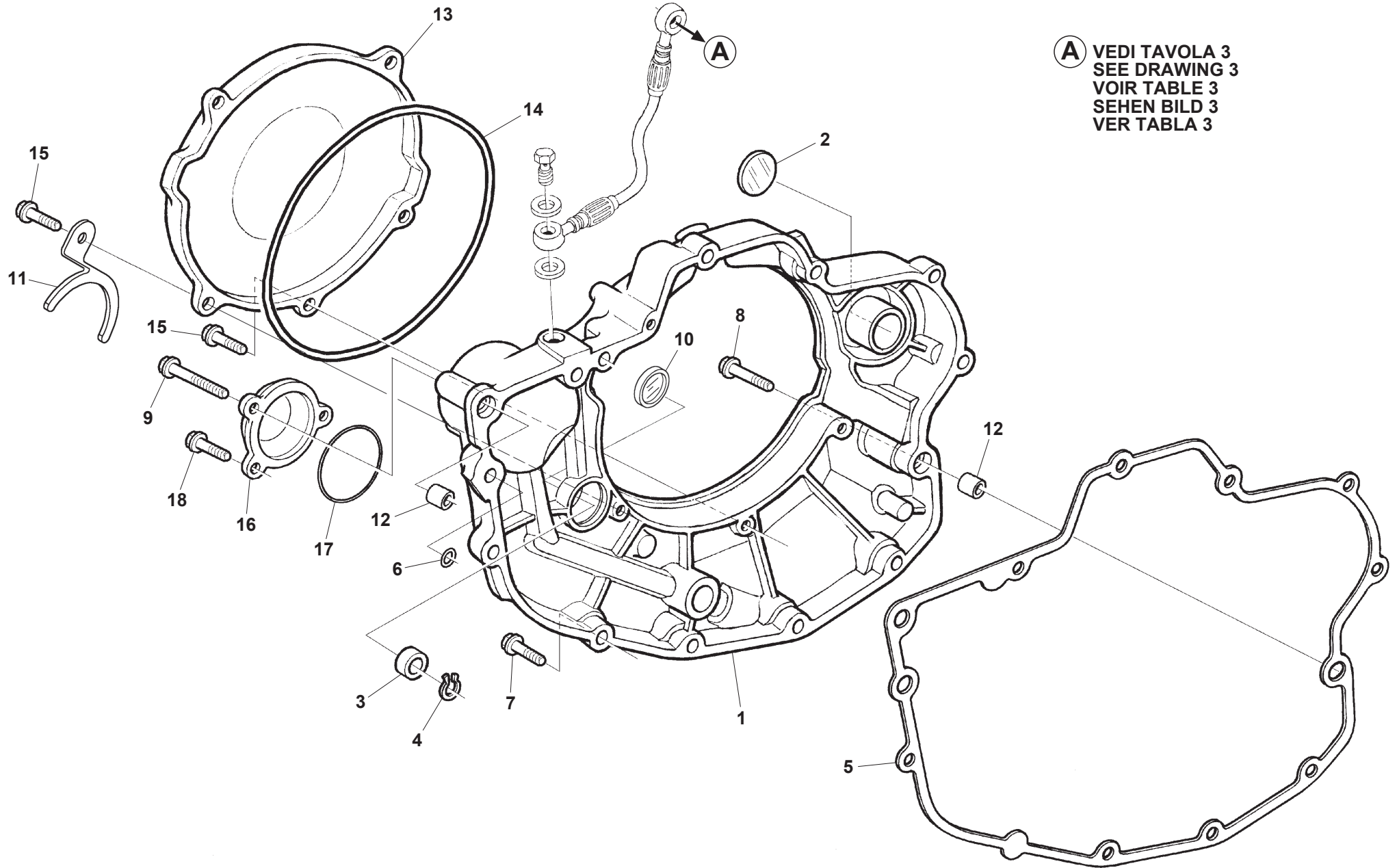

A VEDI TAVOLA 3
SEE DRAWING 3
VOIR TABLE 3
SEHEN BILD 3
VER TABLA 3

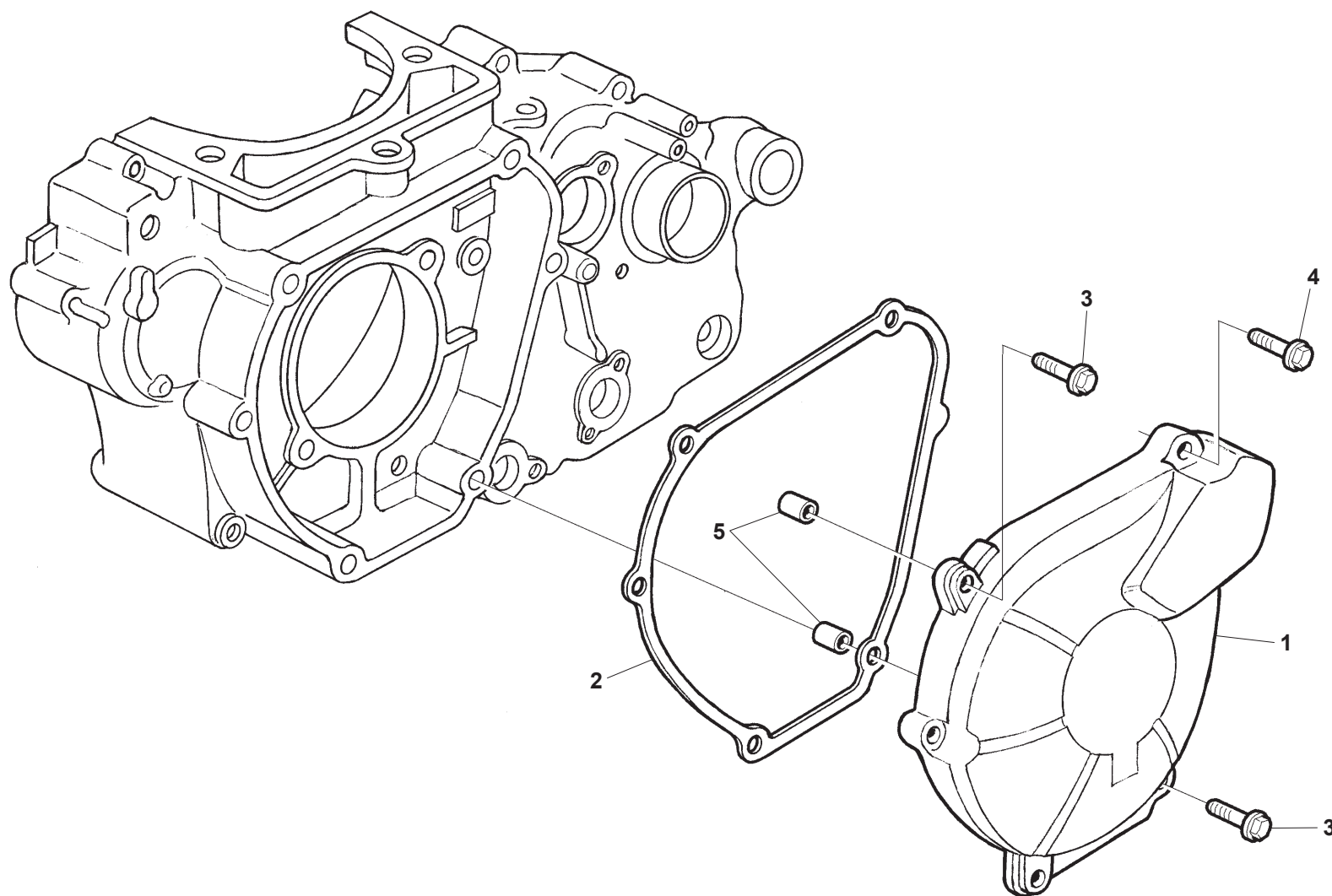



RS 300R/2016
RS 500R/2016
SM 500R/2016

COPERCHI SEMICARTER SINISTRO - L.H. HALF CRANKCASE COVERS
COUVERCLES CARTER G. - GEHAUSEDECKEL L.
TAPAS BANCADA IZQ.

TAVOLA
 DRAWING
 TABLE
 BILD
 TABLA

10

Note Notes Notes Marke Notas	Pos. No. N. Index Pos.	N. Cod. Code No. Nr. Code Code Nr N. Cod.	Q.tà Q.ty Q.te M.ge C.ad	DENOMINAZIONE	NAME	DESIGNATION	BESHREIBUNG	DENOMINACION
	1	M000P00090	1	COPERCHIO GENERATORE	COVER, GENERATOR	COUVERCLE GENERATEUR	DECKEL, STROMGENERATORS	CUBIERTA GENERADOR
	2	800099856	1	GUARNIZIONE COPERCHIO GENERATORE	GASKET, GENERATOR COVER	JOINT COUVERCLE GENERATEUR	DICHTUNG, STROMGENERATOR DECKEL	JUNTA CUBIERTA GENERADOR
	3	ZA0067545	2	VITE TEF M6X1,00X35 CH8	SCREW TEF M6X1.00X35 CH8	VIS TEF M6X1,00X35 CH8	SCHRAUBE TEF M6X1,00X35 CH8	TORNILLO TEF M6X1,00X35 CH8
	4	Z00062729	4	VITE TEF M6X1X25 CH8	SCREW TEF M6X1X25 CH8	VIS TEF M6X1X25 CH8	SCHRAUBE TEF M6X1X25 CH8	TORNILLO TEF M6X1X25 CH8
	5	800007719	2	GRANO RIFERIMENTO 10X7,2X16	PIN, DOWEL 10X7.2X16	GOUJON DE REFERENCE 10X7,2X16	BEZUGSSTIFT 10X7,2X16	ESPIGA DE REFERENCIA 10X7,2X16

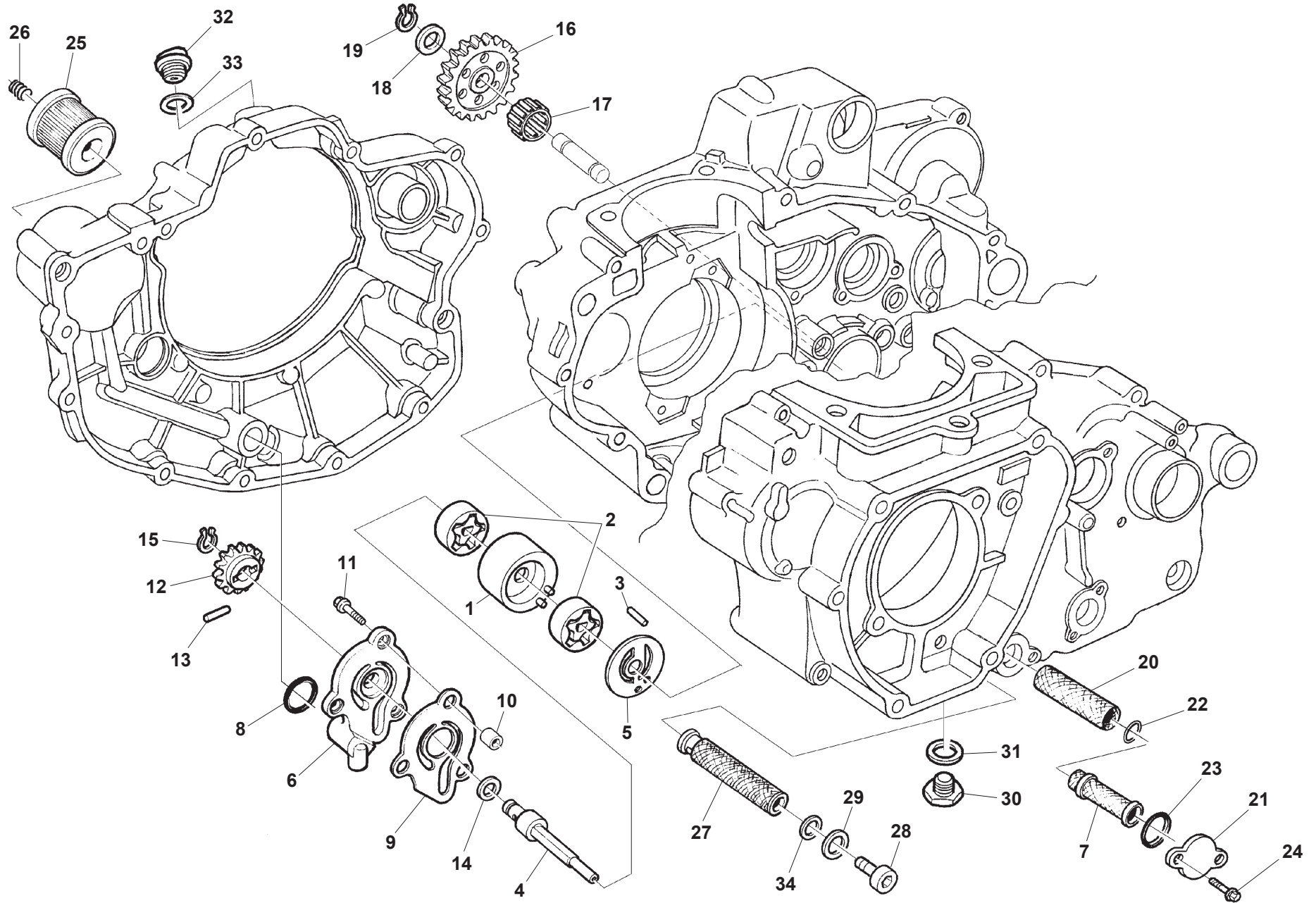



RS 300R/2016
RS 500R/2016
SM 500R/2016

LUBRIFICAZIONE - LUBRIFICATION
GRAISSAGE - SCHMIERUNG
LUBRICACION

TAVOLA
 DRAWING
 TABLE
 BILD
 TABLA

11

Note Notes Notes Marke Notas	Pos. No. Index Pos.	N. Cod. Code No. Nr. Code Code Nr N. Cod.	Q.tà Q.ty Q.te M.ge C.ad	DENOMINAZIONE	NAME	DESIGNATION	BESHREIBUNG	DENOMINACION
	1	800099858	1	CORPO POMPA OLIO	HOUSING, OIL PUMP	CORPS POMPE A HUILE	OELPUMPEGEHAEUSE	CUERPO BOMBA ACEITE
	2	800082948	2	TROCOIDE ASPIRAZIONE OLIO	OIL SUCTION ROTOR	ROTOR ASPIRATEUR HUILE	OELSAUGROTOR	ROTOR ADMISION ACEITE
	3	8A0047773	2	RULLINO	ROLLER	ROULEAU	ROLLE	RODILLO
	4	800099860	1	ALBERO POMPA OLIO	SHAFT, OIL PUMP	ARBRE POMPE A HUILE	WELLE, OELPUMPE	ARBOL, BOMBA ACEITE
	5	800099861	1	DISTANZIALE ROTORE POMPA OLIO	SPACER, OIL PUMP ROTOR	ENTRETOISE ROTOR POMPE A HUILE	ABSTANDHALTER, ROTOR OELPUMPE	DISTANCIADOR ROTOR BOMBA ACEITE
	6	8000H0243	1	COPERCHIO POMPA OLIO	COVER OIL PUMP	COUVERCLE POMPE HUILE	OELPUMPENDECKEL	CUBIERTA BOMBA ACEITE
	7	800072427	1	FILTRO OLIO INTERNO	OIL FILTER, INNER	FILTRE A HUILE INTERIEUR	OELFILTER, INNEN	FILTRO ACEITE INTERIOR
	8	800025082	1	ANELLO O-RING 3056 13,95X2,62	O-RING 13.95X2.62	JOINT TORIQUE 13,95X2,62	O-RING 13,95X2,62	JUNTA TORICA 13,95X2,62
	9	800099862	1	COPERCHIO INTERMEDIO POMPA	COVER	COUVERCLE	DECKEL	CUBIERTA
	10	161795502	2	GRANO RIFERIMENTO 8X6,4X10	PIN DOWEL 8X6.4X10	GOUJON, D'ASSEMBLAGE 8X6,4X10	BEZUGSSTIFT 8X6,4X10	PASADOR ESPIGA DE REFERENCIA 8X6,4X10
	11	Z00062728	3	VITE TEF M6X1X20 CH8	SCREW TEF M6X1X20 CH8	VIS TEF M6X1X20 CH8	SCHRAUBE TEF M6X1X20 CH8	TORNILLO TEF M6X1X20 CH8
	12	800099863	1	INGRANAGGIO CONDOTTO POMPA Z11	GEAR, PUMP DRIVEN T11	ENGRANAGE ENTRAINE PUMPE D11	ANTRIEBSRAD Z11	ENGRANAJE ACCIONADO BOMBA D11
	13	800047773	1	RULLINO	ROLLER	ROULEAU	ROLLE	RODILLO
	14	8E0034292	1	RONDELLA 14X8,2	WASHER 14X8.2	RONDELLE 14X8,2	SCHEIBE 14X8,2	ARANDELA 14X8,2
	15	800021375	1	ANELLO SEEGER 8mm DIN 471	CIRCLIP 8mm DIN 471	CIRCLIP 8mm DIN 471	SEEGERRING 8mm DIN 471	ANILLO ELASTICO 8mm DIN 471
	16	800099864	1	INGRANAGGIO INTERMEDIO POMPA Z24	IDLE GEAR T24	PIGNON INTERMEDIAIRE D24	FREILAUFRAD Z24	ENGRANAJE INTERMEDIO D24
	17	800033718	1	ASTUCCIO A RULLI HK1210	BEARING, NEEDLE HK1210	ROULEMENT A AIGUILLES HK1210	NADELLAGER HK1210	COJINETE DE AGUJAS HK1210
	18	8A0001261	1	RONDELLA 19X12X0,3	WASHER 19X12X0.3	RONDELLE 19X12X0,3	SCHEIBE 19X12X0,3	ARANDELA 19X12X0,3
	19	66N021202	1	ANELLO SEEGER 12mm	CIRCLIP 12mm	CIRCLIP 12mm	SPRENGRING 12mm	ANILLO SEEGER 12mm
	20	800072426	1	FILTRO OLIO ESTERNO	OIL FILTER, OUTER	FILTRE A HUILE EXTERIEUR	OELFILTER, AUSSER	FILTRO ACEITE EXTERIOR
	21	800072425	1	COPERCHIO FILTRO OLIO	COVER, OIL ELEMENT	COUVERCLE FILTRE A HUILE	DECKEL, OELFILTER	CUBIERTA FILTRO ACEITE
	22	800026884	1	ANELLO O-RING 3062 15,54X2,62	O-RING 3062 15.54X2.62	JOINT TORIQUE 3062 15,54X2,62	O-RING 3062 15,54X2,62	JUNTA TORICA 3062 15,54X2,62
	23	800034609	1	ANELLO O-RING 3087 22X2,62	O-RING 3087 22X2.62	JOINT TORIQUE 3087 22X2,62	O-RING 3087 22X2,62	JUNTA TORICA 3087 22X2,62
	24	Z00066525	2	VITE TEF M5X0,8X12	SCREW TEF M5X0.8X12	VIS TEF M5X0,8X12	SCHRAUBE TEF M5X0,8X12	TORNILLO TEF M5X0,8X12
	25	8000B0593	1	FILTRO OLIO	FILTER, OIL	FILTRE A HUILE	OELFILTER	FILTRO ACEITE
	26	800099866	1	MOLLA FILTRO OLIO	SPRING, OIL FILTER	RESSORT FILTRE A HUILE	FEDER, OELFILTER	RESORTE, FILTRO ACEITE
	27	8A0074716	1	FILTRO OLIO ASPIRAZIONE	STRAINER, OIL	CREPINE HUILE	OLNETZ	REDECILLA ACEITE
	28	800099711	1	TAPPO DIN 908 M14X1,5	PLUG DIN 908 M14X1.5	BOUCHON DIN 908 M14X1,5	VERSCHLUSS DIN 908 M14X1,5	TAPON DIN 908 M14X1,5
	29	62N015678	1	RONDELLA IN ALLUMINIO 21X14,3X1,2	WASHER, ALUMINIUM 21X14.3X1.2	RONDELLE EN ALUMINIUM 21X14,3X1,2	ALUMINIUM SCHEIBE 21X14,3X1,2	ARANDELA ALUMINIO 21X14,3X1,2
	30	800073011	1	TAPPO DRENAGGIO OLIO	PLUG, OIL DRAIN	BOUCHON VIDANGE HUILE	VERSCHLUSS, OELABLASS	TAPON PURGA ACEITE
	31	62N015679	1	RONDELLA IN ALLUMINIO 24X16,3	ALUMINIUM WASHER 24X16.3	RONDELLE EN ALUMINIUM 24X16,3	ALUMINIUM SCHEIBE 24X16,3	ARANDELA DE ALUMINIO 24X16,3
	32	800036786	1	TAPPO ALIMENTAZIONE OLIO	CAP, OIL FILLER	BOUCHON REMPLISSEMENT HUILE	STOEPSSEL OELEINFUELL	TAPON INTRUDUCCION ACEITE
	33	800029171	1	ANELLO O-RING 123 2,65X17,86 mm	O-RING 123 2.65X17.86 mm	JOINT TORIQUE 123 2,65X17,86 mm	O-RING 123 2,65X17,86 mm	JUNTA TORICA 123 2,65X17,86 mm

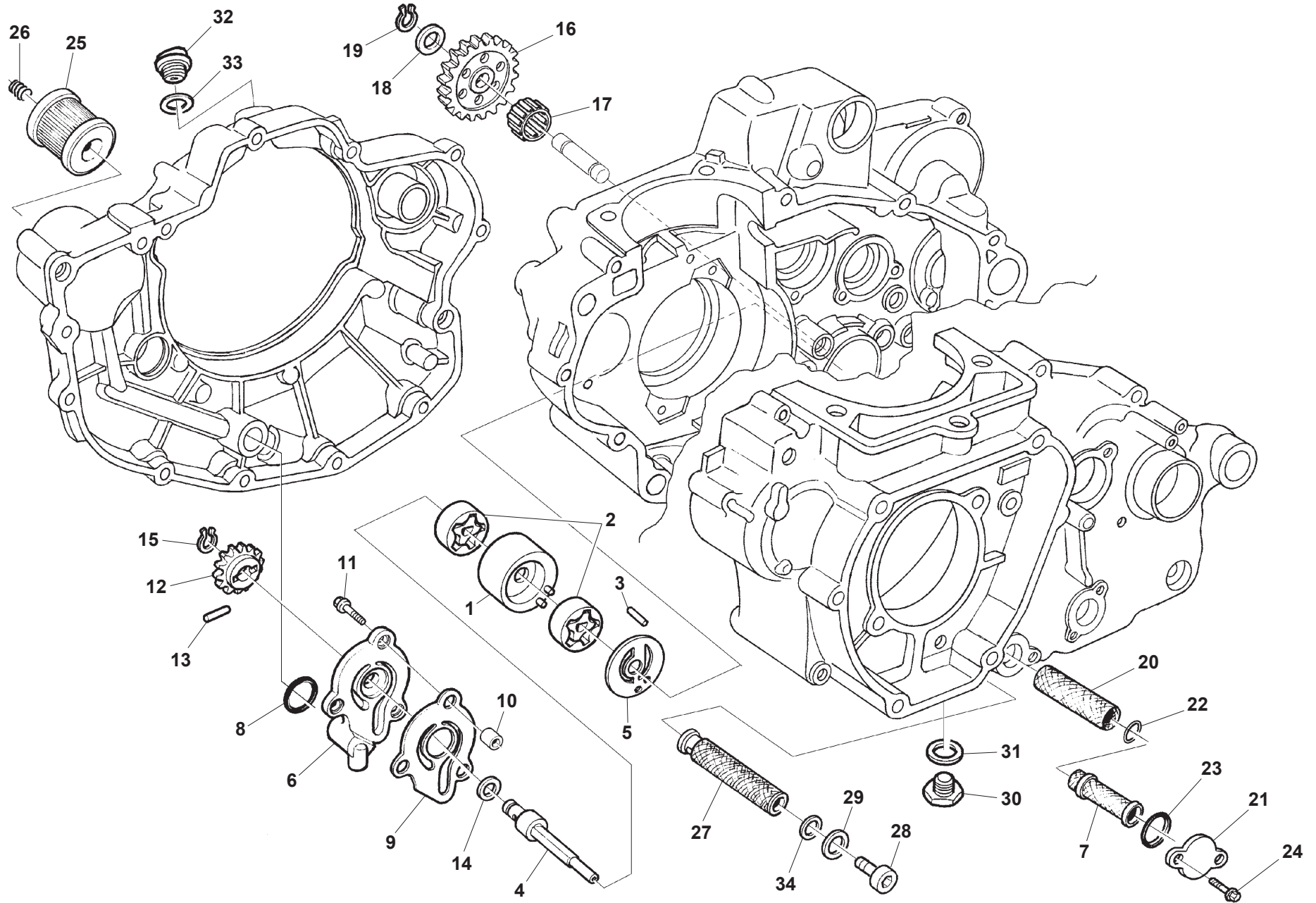

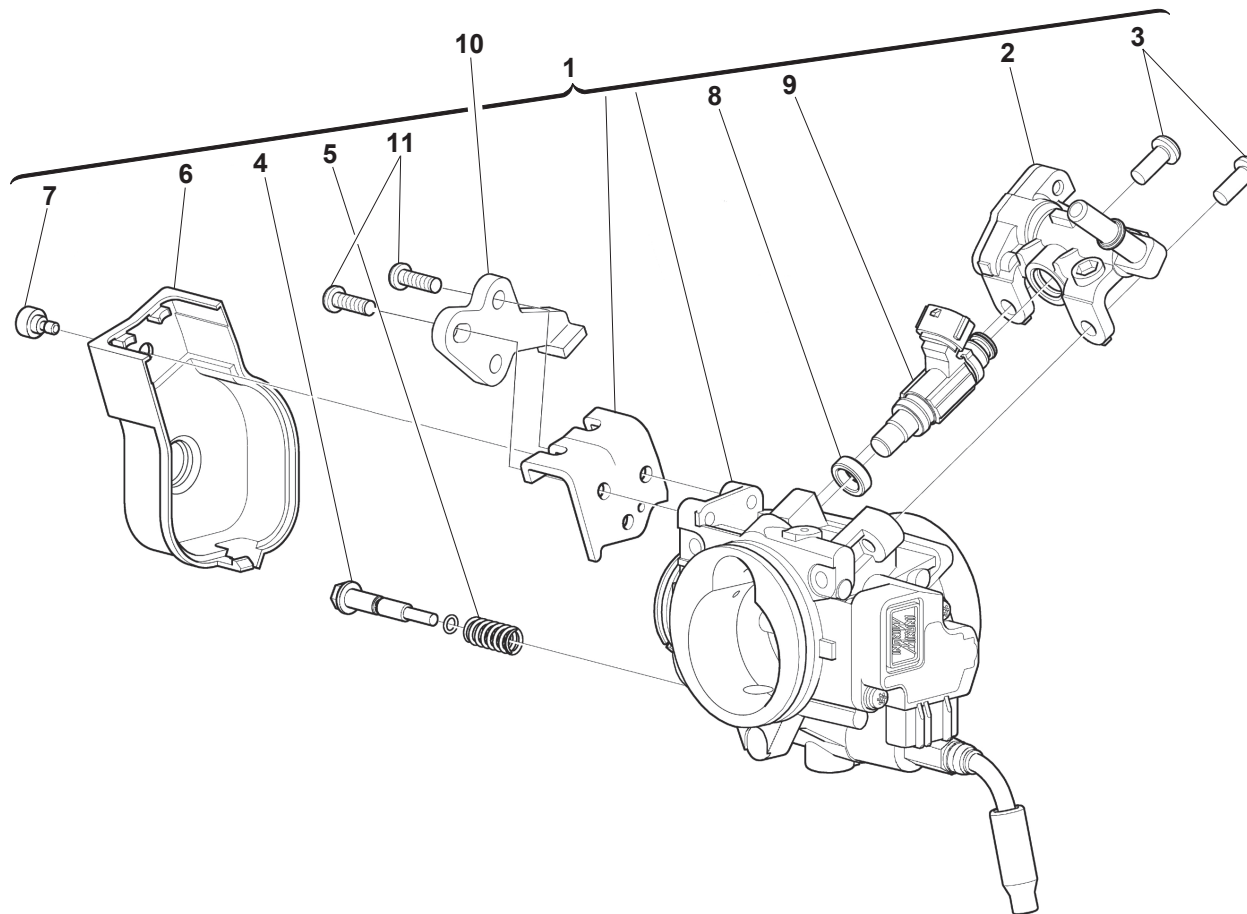

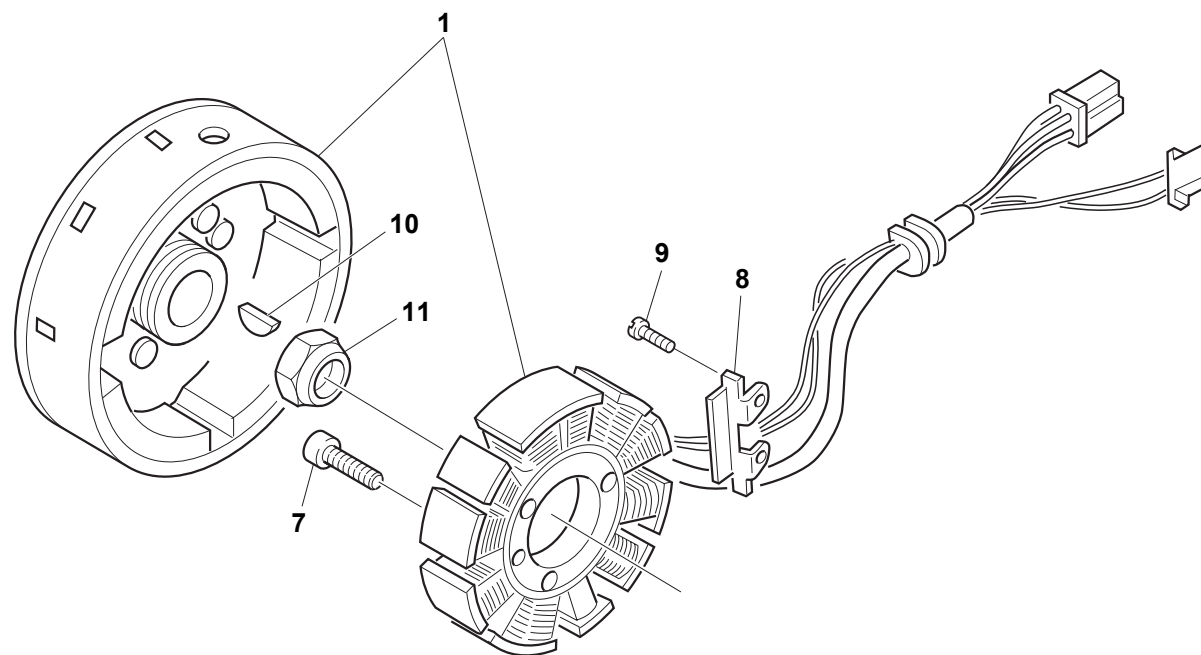
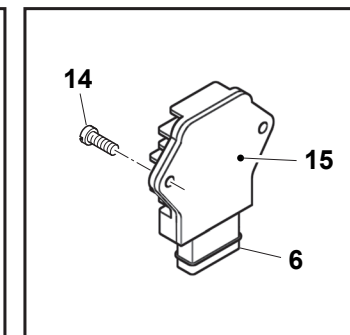
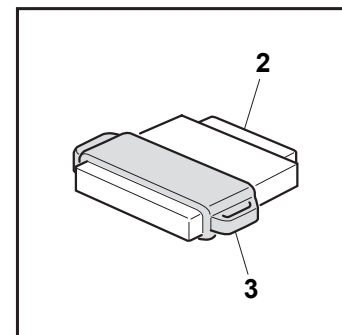
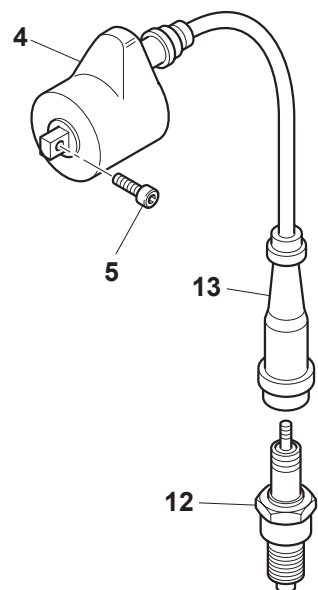



RS 300R/2016
RS 500R/2016
SM 500R/2016

PARTE ELETTRICA - IGNITION SYSTEM
PARTIE ELECTRIQUE
ELEKTRISCHE TEILE - PARTE ELECTRICA

TAVOLA
 DRAWING
 TABLE
 BILD
 TABLA

13

Note Notes Marke Notas	Pos. No. Index Pos.	N. Cod. Code No. Nr. Code Code Nr N. Cod.	Q.tà Q.ty Q.te M.ge C.ad.	DENOMINAZIONE	NAME	DESIGNATION	BESHREIBUNG	DENOMINACION
	1	8000A6737	1	GENERATORE	GENERATOR	GENERATEUR	STROMGENERATOR	GENERADOR
RS 300R	2	EA00P00738	1	CENTRALINA INIEZIONE (EUROPA)	ENGINE CONTROL UNIT (EUROPE)	CENTRALE INJECTION (EUROPE)	EINSPRITZUNG ZENTRALANLAGE (EUROPA)	CENTRAL INYECCION (EUROPA)
RS 500R - SM 500R	2	EB00P00738	1	CENTRALINA INIEZIONE (EUROPA)	ENGINE CONTROL UNIT (EUROPE)	CENTRALE INJECTION (EUROPE)	EINSPRITZUNG ZENTRALANLAGE (EUROPA)	CENTRAL INYECCION (EUROPA)
	3	F000P00132	1	SUPPORTO CENTRALINA INIEZIONE	BRACKET ENGINE CONTROL UNIT	SUPPORT UNITE' CONTROLE INJECTION	HALTER, EINSPIRITZUNG ZENTRALANLAGE	SOPORTE CENTRAL INYECCION
	4	8000H0276	1	BOBINA ACCENSIONE	COIL, IGNITION	BOBINE ALLUMAGE	ZUENDSPULE	BOBINA ENCENDIDO
	5	Z00062728	2	VITE TEF M6X1X20 CH8	SCREW TEF M6X1X20 CH8	VIS TEF M6X1X20 CH8	SCHRAUBE TEF M6X1X20 CH8	TORNILLO TEF M6X1X20 CH8
	6	8000B0563	1	REGOLATORE DI TENSIONE	REGULATOR & RECTIFIER	REGULATEUR TENSION	SPANNUNGSREGLER	REGULADOR TENSION
	7	60ND02488	3	VITE TCEI M5X0,8X25	SCREW TCEI M5X0,8X25	VIS TEF TCEI M5X0,8X25	SCHRAUBE TCEI M5X0,8X25	TORNILLO TCEI M5X0,8X25
	8	800099868	1	FERMACAVO	CLAMP, WIRE	COLLIER, CORDON	KABELKLEMME	GRAMPA CORDON
	9	ZA0067997	2	VITE TEF M5X0,8X16	SCREW TEF M5X0,8X16	VIS TEF M5X0,8X16	SCHRAUBE TEF M5X0,8X16	TORNILLO TEF M5X0,8X16
	10	151371301	1	CHIAVETTA WOODRUFF	KEY, WOODRUFF	CLAVETTE, DEMI-LUNE WOODRUFF	EINLEGE KEIL, WOODRUFF	CHAVETA WOODRUFF
	11	8000A0033	1	DADO FLANGIATO M12X1	NUT FLANGE M12X1	ECROU BRIDE M12X1	GEFLANSCHTE MUTTER M12X1	TUERCA CON REBORDE M12X1
	12	8000A0573	1	CANDELA	PLUG, SPARK	BOUGIE	ZUENDKERZE	BUJIA
	13	8000A6740	1	PIPETTA CANDELA	CAP, SPARK PLUG	ANTIPARASITE	ZUENDKERZENSTECKER	CAPUCHON PORTA BUJIA
	14	Z00062728	2	VITE TEF M6X1X20 CH8	SCREW TEF M6X1X20 CH8	VIS TEF M6X1X20 CH8	SCHRAUBE TEF M6X1X20 CH8	TORNILLO TEF M6X1X20 CH8
	15	8000B1061	1	PIASTRA	PLATE	PLAQUE	PLATTE	PLACA

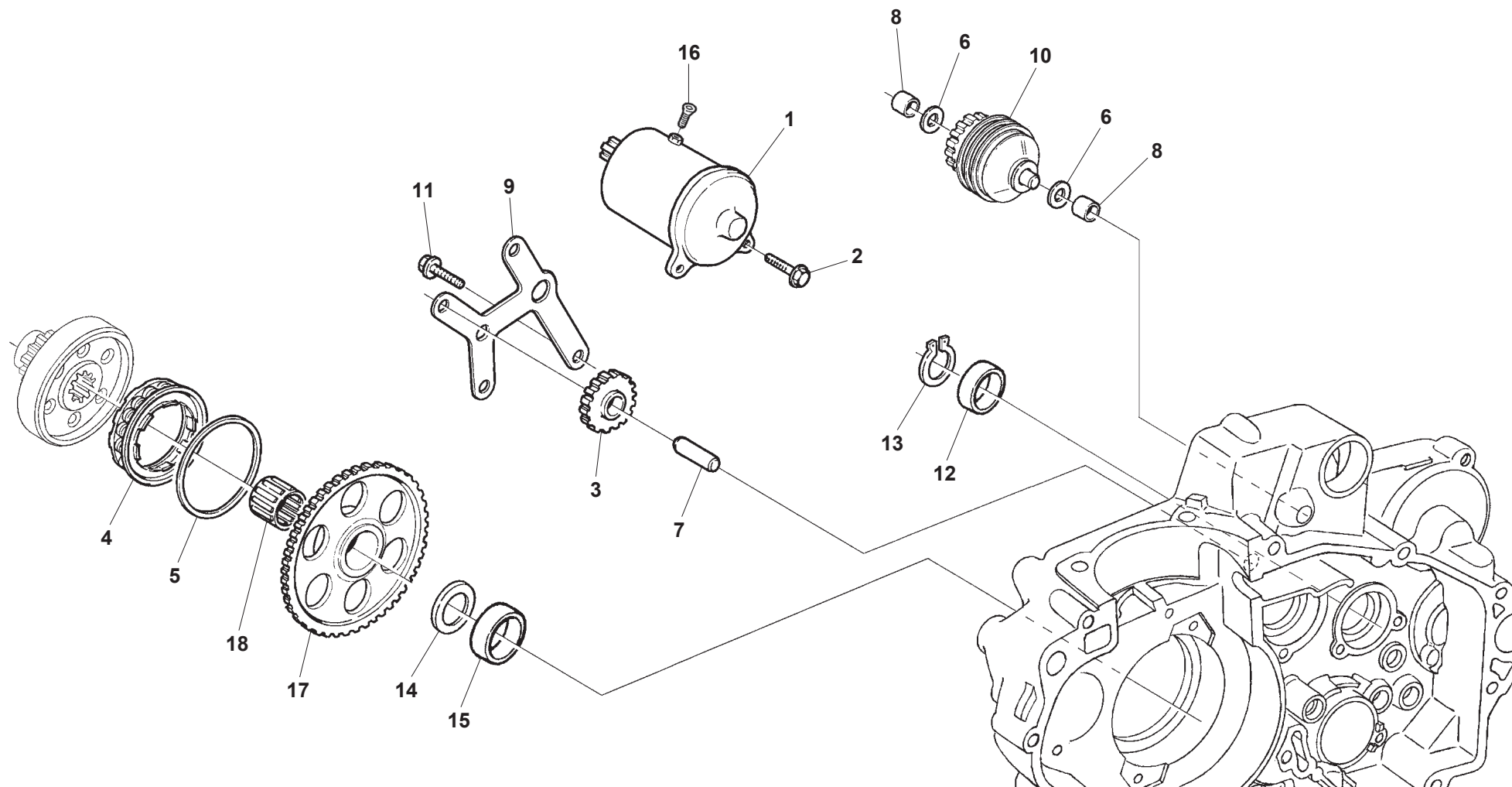



RS 300R/2016
RS 500R/2016
SM 500R/2016

AVVIAMENTO - STARTING
DEMARRAGE - ANLASSER
ARRANQUE

TAVOLA
 DRAWING
 TABLE
 BILD
 TABLA

14

Note Notes Marke Notas	Pos. No. Index Pos.	N. Cod. Code No. Nr. Code Code Nr N. Cod.	Q.tà Q.ty Q.te M.ge C.ad	DENOMINAZIONE	NAME	DESIGNATION	BESHREIBUNG	DENOMINACION
	1	8000B1373	1	MOTORINO AVVIAMENTO	STARTING MOTOR	DEMARREUR ELECTRIQUE	ANLASSERMOTOR	MOTOR ARRANQUE
	2	Z00062729	2	VITE TEF M6X1X25 CH8	SCREW TEF M6X1X25 CH8	VIS TEF M6X1X25 CH8	SCHRAUBE TEF M6X1X25 CH8	TORNILLO TEF M6X1X25 CH8
	3	800099958	1	INGRANAGGIO INTERMEDIO Z24	IDLE GEAR 24 T	PIGNON INTERMEDIAIRE D24	FREILAUFRAD Z24	ENGRANAJE INTERMEDIO D24
	4	8000A0709	1	RUOTA LIBERA	CLUTCH, ONE WAY	ROUE LIBRE	EINWEGKUPPLUNG	EMBRAGUE, UNA VIA
	5	8000A0710	1	DISCO RITEGNO RUOTA LIBERA	RETAINER, CLUTCH ONE WAY	ARRETOIR ROUE LIBRE	FREILAUF VERSCHLUSS	RETEN RUEDA LIBRE
	6	800005876	2	RONDELLA 18X10X0,5	WASHER 18X10X0,5	RONDELLE 18X10X0,5	SCHEIBE 18X10X0,5	ARANDELA 18X10X0,5
	7	800099960	1	PERNO INGRANAGGIO INTERMEDIO	STARTER REDUCTION SHAFT	PIVOT ENGRANAGE	ZAHNRADSTIFT	PERNO ENGRANAJE INTERMEDIO
	8	8000A1017	2	BOCCOLA	BUSH	DOUILLE	BUCHSE	BUJE
	9	8000A1022	1	PIASTRA	PLATE	PLAQUE	PLATTE	PLACA
	10	8000A1279	1	FRIZIONE AVVIAMENTO ELETTRICO	CLUTCH, ELECTRIC START	EMBRAYAGE, DEMARRAGE ELECTRIQUE	KUPPLUNG, ELEKROANLASSER	EMBRAGUE ARRANQUE ELECTRICO
	11	Z00062727	4	VITE TE M6X1X16 CH8	SCREW TE M6X1X16 CH8	VIS TE M6X1X16 CH8	SCHRAUBE TE M6X1X16 CH8	TORNILLO TE M6X1X16 CH8
	12	8000A0746	1	DISTANZIALE	SPACER	ENTRETOISE	ABSTANDHALTER	DISTANCIADOR
	13	66N021208	1	ANELLO ELASTICO 28X16,5 mm	SPRING RING 28X16.5 mm	BAGUE ELASTIQUE 28X16,5 mm	FEDERRING 28X16,5 mm	ANILLO ELASTICO 28X16,5 mm
	14	M000P00258	1	RONDELLA RASAMENTO	WASHER, THRUST	RONDELLE BUTEE	DISTANZSCHEIBE	ARANDELA SEPARACION
	15	800099957	1	DISTANZIALE	SPACER	ENTRETOISE	ABSTANDHALTER	DISTANCIADOR
	16	ZF0067997	1	VITE TEF M5X0,8X6,5	SCREW TEF M5X0,8X6,5	VIS TEF M5X0,8X6,5	SCHRAUBE TEF M5X0,8X6,5	TORNILLO TEF M5X0,8X6,5
	17	8000A0739	1	CORONA DENTATA Z70	RING GEAR T70	COURONNE DENTEE D70	ZAHNRAD Z70	CORONA DENTADA D70
	18	800035763	1	GABBIA A RULLI K28X33X17	NEEDLE BEARING K28X33X17	CAGE A ROULEMENT K28X33X17	ROLLENKAEFIG K28X33X17	JAULA DE RODILLOS K28X33X17

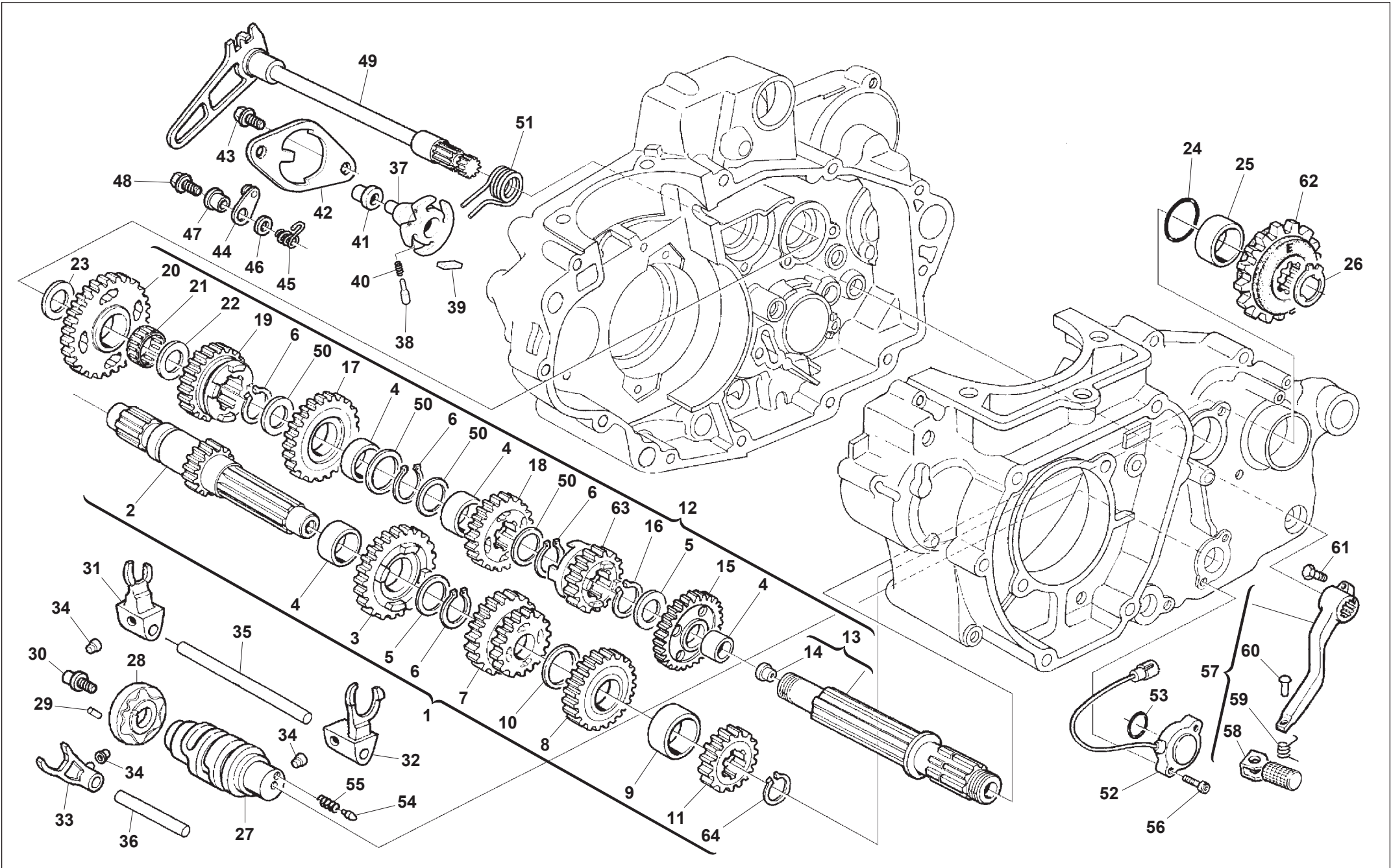

Note Notes Notas	Pos. No. Index Pos.	N. Cod. Code No. Nr. Code Code Nr N. Cod.	Q.tà Q.ty M.ge C.ad	DENOMINAZIONE	NAME	DESIGNATION	BESHREIBUNG	DENOMINACION
	1	8000A3511	1	ALBERO PRIMARIO COMPLETO	COMPLETE MAIN SHAFT	ARBRE PRIMAIRE COMPLET	KOMPLETTE HAUPTWELLE	ARBOL PRIMARIO COMPLETO
	2	8000A3512	1	ALBERO PRIMARIO Z14	AXLE MAIN 14T	ARBRE PRIMAIRE D14	HAUPTWELLE Z14	ARBOL PRIMARIO CAMBIO D14
	3	800088244	1	INGRANAGGIO CONDUTTORE 5A Z25	GEAR, 5TH PINION 25T	ENGRENAGE MENANT 5EME VITESSE D25	TREIBENDES ZAHNRAD 5. GESCHWIND. Z25	ENGRANAJE CONDUCTOR 5A VELOCIDAD D25
	4	800063822	5	BOCCOLA 28X25X7	BUSH 28X25X7	DOUILLE 28X25X7	BUCHSE 28X25X7	BUJE 28X25X7
	5	8D0036022	2	RONDELLA RASAMENTO 32X25,1X0,5 mm	THRUST WASHER 32X25.1X0.5 mm	RONDELLE DE BUTEE 32X25,1X0,5 mm	DISTANZSCHEIBE 32X25,1X0,5 mm	ARANDELA DE SEPARACION 32X25,1X0,5 mm
	6	800031772	4	ANELLO ELASTICO 23,2X1,2	CIRCLIP 23.2X1.2	BAGUE ELASTIQUE 23,2X1,2	SPRENGRING 23,2X1,2	ANILLO ELASTICO 23,2X1,2
	7	8000A3972	1	INGRANAGGIO CONDUTTORE 3A-4A Z18/23	GEAR DRIVE 3/4TH SPEED T18/23	ENGRENAGE MENANT 3/4EME VITESSE D18/23	TREIBENDES ZAHNRAD 3/4. GESCHWIND.Z18/23	ENGRANAJE CONDUCTOR 3/4A VEL. D18/23
	8	800088246	1	INGRANAGGIO CONDOTTO 6A Z27	DRIVEN GEAR 6TH SPEED 27T	ENGRENAGE ENTRAINE 6EME VITESSE D27	ANGETRIEBENES ZAHNRAD 6. GESCHWIND.Z27	ENGRANAJE ACCIONADO 6A VELOCIDAD D27
	9	8A0061261	1	BOCCOLA 25X22	BUSH 25X22	DOUILLE 25X22	BUCHSE 25X22	CASQUILLO 25X22
	10	8B0036023	1	RONDELLA RASAMENTO	WASHER, THRUST	RONDELLE BUTEE	DISTANZSCHEIBE	ARANDELA SEPARACION
	11	800088247	1	INGRANAGGIO CONDUTTORE 2A Z18	GEAR, INPUT 2ND, 18T	ENGRENAGE MENANT 2EME VITESSE D18	TREIBENDES ZAHNRAD 2. GESCHWIND. Z18	ENGRANAJE CONDUCTOR 2NDA VELOCIDAD D18
	12	M000A00808	1	ALBERO SECONDARIO COMPLETO	COUNTER SHAFT ASSY	ARBRE SECONDAIRE COMPLET	NEBENGETRIEBEWELLE KOMPL.	ARBOL SECONDARIO CAMBIO COMPLETO
	13	M000A00809	1	ALBERO SECONDARIO	COUNTER SHAFT	ARBRE SECONDAIRE	ANTRIEBSWELLE	ARBOL SECONDARIO
	14	800057196	1	TAPPO 12X6X10	PLUG 12X6X10	BOUCHON 12X6X10	VERSCHLUSS 12X6X10	TAPON 12X6X10
	15	8000A1918	1	INGRANAGGIO CONDOTTO 2A Z29	DRIVEN GEAR 2ND SPEED T29	ENGRENAGE ENTRAINE 2EME VITESSE D29	ANGETRIEBENES ZAHNRAD 2. GESCHWIND.Z29	ENGRANAJE ACCIONADO 2NDA VELOCIDAD D29
	16	66N021211	3	ANELLO SEEGER 25mm DIN471	CIRCLIP 25mm DIN471	CIRCLIP 25mm DIN471	SPRENGRING 25mm DIN471	ANILLO SEEGER 25mm DIN471
	17	800088254	1	INGRANAGGIO CONDOTTO 4A Z25	DRIVEN GEAR 4TH SPEED T:25	ENGRENAGE ENTRAINE 4EME VITESSE D25	ANGETRIEBENES ZAHNRAD 4. GESCHWIND.Z25	ENGRANAJE ACCIONADO 4A VELOCIDAD D25
	18	8000A3970	1	INGRANAGGIO CONDOTTO 3A Z24	DRIVEN GEAR 3TH SPEED T24	ENGRENAGE ENTRAINE 3EME VITESSE D24	ANGETRIEBENES ZAHNRAD 3. GESCHWIND. Z24	ENGRANAJE ACCIONADO 3ERA VELOCIDAD D24
	19	8000A1920	1	INGRANAGGIO CONDOTTO 5A Z23	DRIVEN GEAR 5TH SPEED 23T	ENGRENAGE ENTRAINE 5EME VITESSE D23	ANGETRIEBENES ZAHNRAD 5. GESCHWIND.Z23	ENGRANAJE ACCIONADO 5A VELOCIDAD D23
	20	8000A1921	1	INGRANAGGIO CONDOTTO 1A Z28	DRIVEN GEAR 1ST SPEED T28	ENGRENAGE ENTRAINE 1ERE VITESSE D28	ANGETRIEBENES ZAHNRAD 1. GESCHWINDIG Z28	ENGRANAJE ACCIONADO 1ERA VELOCIDAD D28
	21	800022373	1	GABBIA A RULLI 20X24X10	BEARING, NEEDLE 20X24X10	ROULEMENT A AIGUILLES 20X24X10	NADELLAGER 20X24X10	COJINETE DE AGUJAS 20X24X10
	22	8G0007989	1	RONDELLA 28X20X1	WASHER 28X20X1	RONDELLE 28X20X1	SCHEIBE 28X20X1	ARANDELA 28X20X1
	23	8G0007989	1	RONDELLA 28X20X1	WASHER 28X20X1	RONDELLE 28X20X1	SCHEIBE 28X20X1	ARANDELA 28X20X1
	24	800041693	1	ANELLO O-RING 21,95X1,78	O-RING 21.95X1.78	JOINT TORIQUE 21,95X1,78	O-RING 21,95X1,78	JUNTA TORICA 21,95X1,78
	25	800086953	1	DISTANZIALE	SPACER	ENTRETOISE	ABSTANDHALTER	DISTANCIADOR
	26	66N021211	1	ANELLO SEEGER 25mm DIN471	CIRCLIP 25mm DIN471	CIRCLIP 25mm DIN471	SPRENGRING 25mm DIN471	ANILLO SEEGER 25mm DIN471
	27	8000H0246	1	TAMBURO DESMODROMICO	CAM, GEAR SHIFT	TAMBOUR DESMODROMIQUE	VERSCHIEBENOCKEN	TAMBOR CAMBIO
	28	8A0097739	1	ROCCHETTO DESMODROMICO	CAM-CHANGE DRUM	PIGNION DESMODROMIQUE	VERSCHIEBENOCKENRITZEL	PINION TAMBOR CAMBIO
	29	800038520	1	RULLO 4X8	ROLLER 4X8	ROULEAU 4X8	ROLLE 4X8	RODILLO 4X8
	30	800098149	1	VITE	SCREW	VIS	SCHRAUBE	TORNILLO
	31	8A0086980	1	FORCELLA SELETTORE CAMBIO 1A-4A	SHIFT FORK 1-4	FOURCHETTE SELECTEUR 1-4	SCHALTGABEL 1-4	HORQUILLA SELECTOR 1-4
	32	8A0048127	1	FORCELLA SELETTORE CAMBIO 2A-3A	SHIFT FORK 2-3	FOURCHETTE SELECTEUR 2-3	SCHALTGABEL 2-3	HORQUILLA SELECTOR 2-3
	33	800099738	1	FORCELLA SELETTORE CAMBIO 5A-6A	SHIFT FORK 5-6	FOURCHETTE SELECTEUR 5-6	SCHALTGABEL 5-6	HORQUILLA SELECTOR 5-6

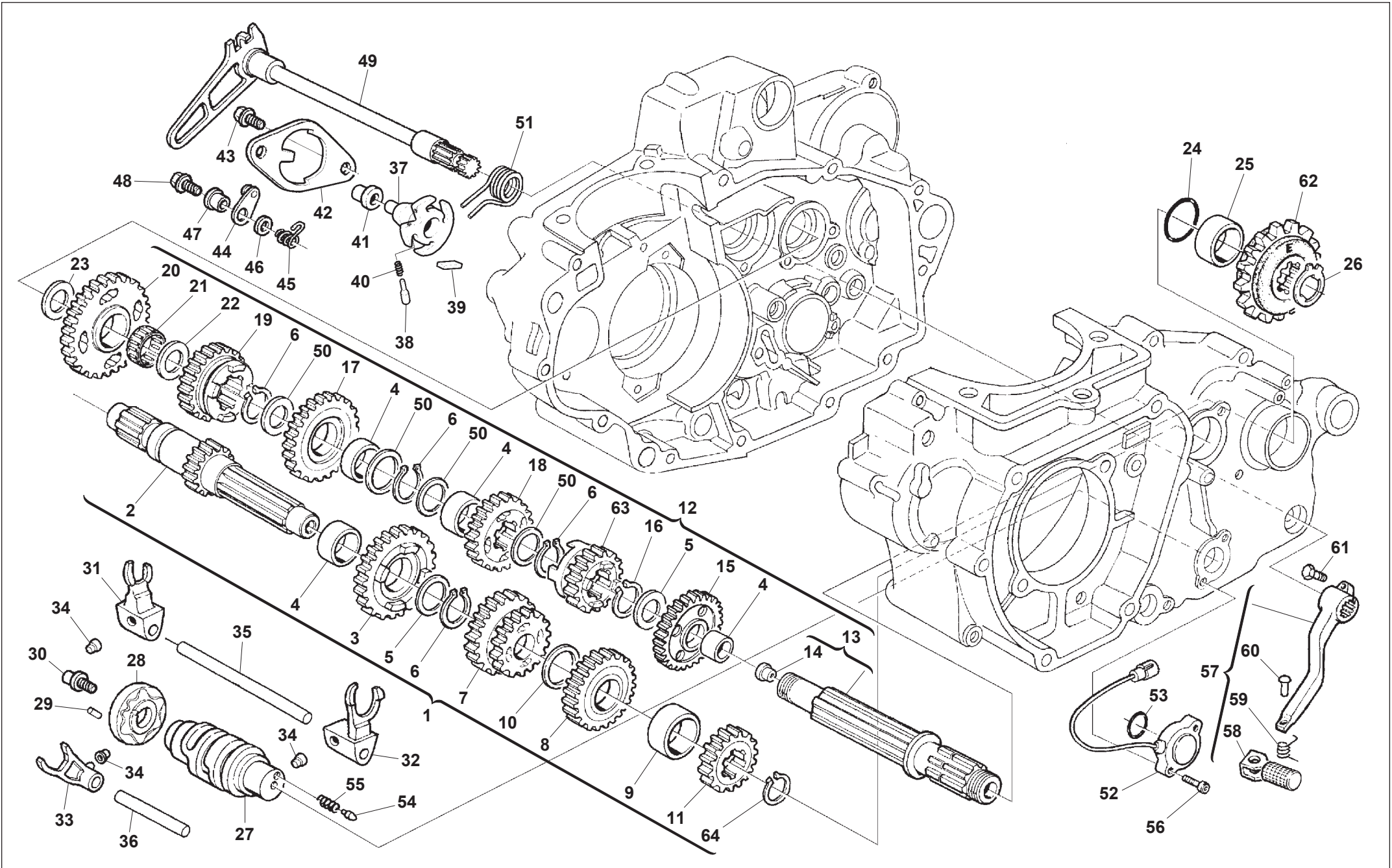



RS 300R/2016
RS 500R/2016
SM 500R/2016

CAMBIO, COMANDO CAMBIO - TRANSMISSION SHIFTER
BOITE DE VITESSE, COMMANDE DE VITESSE
WECHSELGETRIEBE, GANGSCHALTUNG - CAMBIO, MANDO CAMBIO

TAVOLA
DRAWING
TABLE
BILD
TABLA

15

Note Notes Marke Notas	Pos. No. Index Pos.	N. Cod. Code No. Nr. Code Code Nr N. Cod.	Q.tà Q.ty M.ge C.ad	DENOMINAZIONE	NAME	DESIGNATION	BESHREIBUNG	DENOMINACION
	34	800071010	3	ROTELLA	ROLLER	ROULEAU	ROLLENKERN	RODILLO
	35	800038711	1	ASSE FORCHETTA CAMBIO 96 mm	AXLE, SHIFT FORK GUIDE 96 mm	AXE FOURCHETTE CHANGEMENT VITESSE 96 mm	ACHSE, GANGSCHALTGABEL 96 mm	EJE GUIA HORQUILLA CAMBIO 96 mm
	36	800038712	1	ASSE FORCHETTA CAMBIO 57,5 mm	AXLE, SHIFT FORK GUIDE 57.5 mm	AXE FOURCHETTE CHANGEMENT VITESSE 57,5 mm	ACHSE, GANGSCHALTGABEL 57,5 mm	EJE GUIA HORQUILLA CAMBIO 57,5 mm
	37	8000H0247	1	ROCCHETTO SELETTORE	SELECTOR SPROCKET	CROCHET SELECTEUR	KLEINRAD GANGWAHL	CORONA SELECTOR
	38	8000A7515	2	SALTARELLO ROCCHETTO	PAWL	CLIQUET	STRUMHAKEN	SALTARELO
	39	800071008	2	PUNTALE SALTARELLO	PUSH ROD	BARRE PRESSION	DRUCKSTANGE	VARILLA PRESION
	40	800071009	2	MOLLA PUNTALE	SPRING	RESSORT	FEDER	MUELLE
	41	800071010	1	ROTELLA	ROLLER	ROULEAU	ROLLENKERN	RODILLO
	42	8000A7514	1	PIASTRINA	PLATE	PLAQUETTE	PLAETTCHEN	PLETINA
	43	Z00062726	2	VITE TEF M6X1,00X14 CH8	SCREW TEF M6X1.00X14 CH8	VIS TEF M6X1,00X14 CH8	SCHRAUBE TEF M6X1,00X14 CH8	TORNILLO TEF M6X1,00X14 CH8
	44	800085495	1	SALTARELLO FISSA MARCE	GEAR FIXING CLICK ASSEMBLY	CLIQUET COMPLETE	SPERRKLINKE. KPL.	TRINQUETE FIJO MARCHAS
	45	8000A1748	1	MOLLA	SPRING	RESSORT	FEDER	MUELLE
	46	800086107	1	RONDELLA RASAMENTO 6,2X20	THRUST WASHER 6.2X20	RONDELLE DE BUTEE 6,2X20	DISTANZSCHEIBE 6,2X20	ARANDELA DE SEPARACION 6,2X20
	47	800085493	1	BUSSOLA ROTAZIONE SALTARELLO	BUSH	DOUILLE	BUCHSE	BUJE
	48	Z00062726	1	VITE TEF M6X1,00X14 CH8	SCREW TEF M6X1.00X14 CH8	VIS TEF M6X1,00X14 CH8	SCHRAUBE TEF M6X1,00X14 CH8	TORNILLO TEF M6X1,00X14 CH8
	49	800091559	1	ALBERO SELETTORE CAMBIO	GEAR SELECTOR SHAFT	ARBRE SELECTEUR	SCHALTWELLE	ARBOL SELECTOR
	50	800088255	4	RONDELLA RASAMENTO	WASHER, THRUST	RONDELLE BUTEE	DISTANZSCHEIBE	ARANDELA SEPARACION
	51	8A00A7329	1	MOLLA CAMBIO	SPRING, SHIFT RETURN	RESSORT RAPPEL LEVIER COMMANDE	RUECKHOLFEDER SCHALTHEBEL	MUELLE RETRACTOR PALANCA CAMBIO
	52	8000A6751	1	SEGNALATORE MARCE	SENSOR ASSY, GEAR POSITION	CAPEUR POINT MORT	SENSOR LEERLAUF	SENSOR PUNTO MUERTO
	53	8A0042700	1	ANELLO O-RING 2093 23,52X1,78 mm	O-RING 2093 23.52X1.78 mm	JOINT TORIQUE 2093 23,52X1,78 mm	O-RING 2093 23,52X1,78 mm	JUNTA TORICA 2093 23,52X1,78 mm
	54	800042676	1	PUNTALE FOLLE	POINT, NEUTRAL	CONTACTEUR POINT-MORT	BOLZEN LEERLAUF	PUNTO NEUTRO
	55	800042677	1	MOLLA PUNTALE	SPRING	RESSORT	FEDER	MUELLE
	56	Z00066525	2	VITE TEF M5X0,8X12	SCREW TEF M5X0.8X12	VIS TEF M5X0,8X12	SCHRAUBE TEF M5X0,8X12	TORNILLO TEF M5X0,8X12
	57	8000A3488	1	PEDALE CAMBIO	PEDAL, GEAR CHANGE	PEDALE CHANGEMENT VITESSE	SCHALTPEDAL	PEDAL, CAMBIO VELOCIDADES
	58	8A00A3485	1	BRACCIO PEDALE CAMBIO	ARM, GEAR SHIFT LEVER	BRAS PEDAL CHANGEMENT VITESSE	ARM, SCHALTPEDAL	BRAZO, PEDAL CAMBIO
	59	800070216	1	MOLLA	SPRING	RESSORT	FEDER	MUELLE
	60	800099744	1	RIBATTINO 6X22 UNI 748	RIVET 6X22 UNI 748	RIVET 6X22 UNI 748	NIETE 6X22 UNI 748	REMACHE 6X22 UNI 748
	61	Z00062728	1	VITE TEF M6X1X20 CH8	SCREW TEF M6X1X20 CH8	VIS TEF M6X1X20 CH8	SCHRAUBE TEF M6X1X20 CH8	TORNILLO TEF M6X1X20 CH8
RS 300R - RS 500R	62	M000P00806	1	PIGNONE Z13	SPROCKET, CHAIN 13T	PIGNON CHAINE D13	KETTENRITZEL Z13	PINON CADENA D13
SM 500R	62	M000P00712	1	PIGNONE Z15	SPROCKET, CHAIN T15	PIGNON CHAINE Z15	KETTENRITZEL Z15	PINON CADENA Z15
	63	8000A1919	1	INGRANAGGIO CONDOTTO 6A Z 22	DRIVEN GEAR 6TH SPEED T22	ENGRENAGE ENTRAINE 6ME VITESSE D22	ANGETRIEBENES ZAHNRAD 6. GESCHWIND. Z22	ENGRANAJE ACCIONADO 6A VELOCIDAD D22
	64	66N021206	1	ANELLO SEEGER 25 mm	CIRCLIP 25 mm	CIRCLIP 25 mm	SPRENGRING 25 mm	ANILLO SEEGER 25 mm

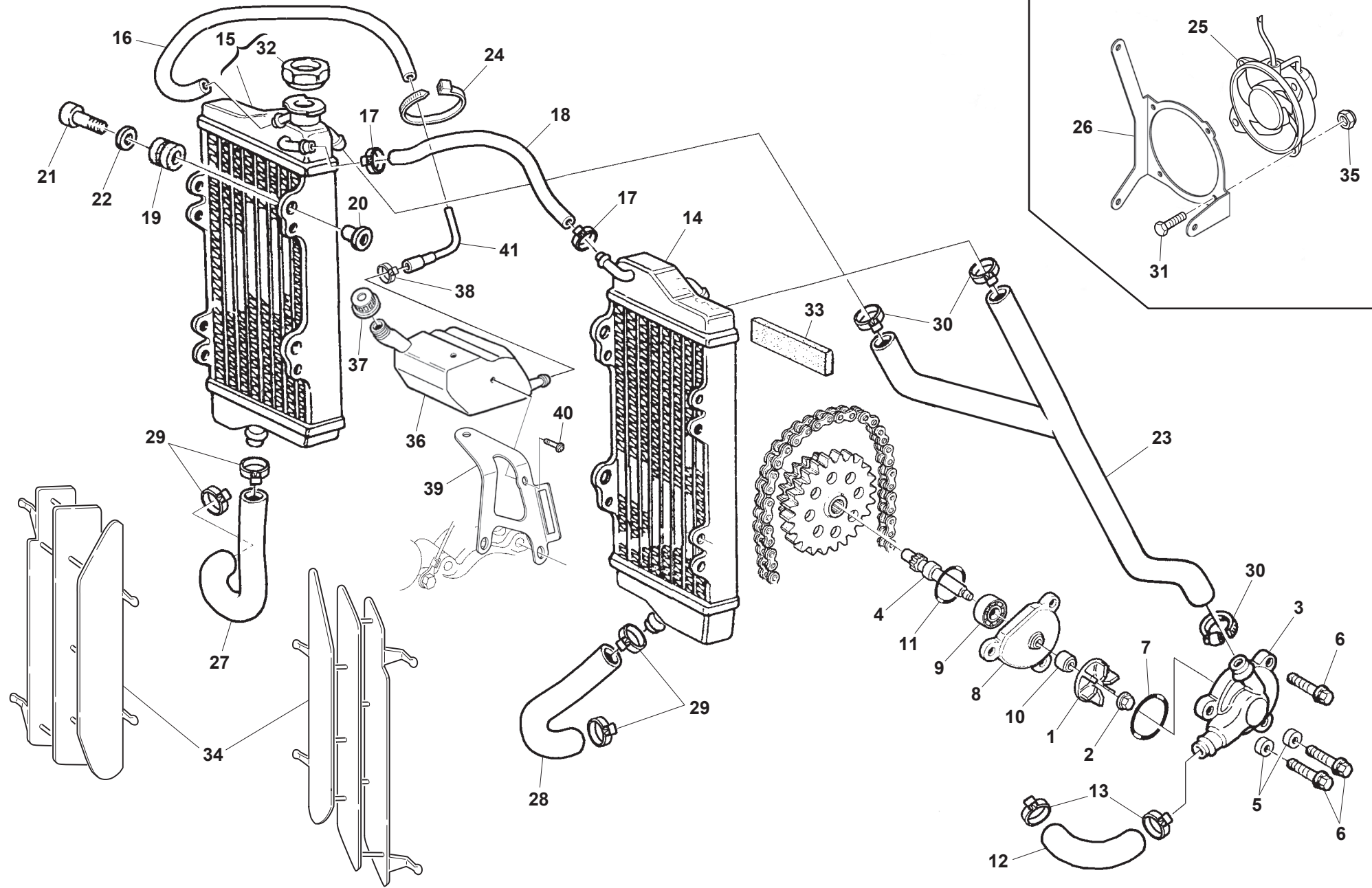



RS 300R/2016
RS 500R/2016
SM 500R/2016

RAFFREDDAMENTO - COOLING SYSTEM
REFROIDISSEMENT - WASSERKÜHLUNG
ENFRIAMIENTO

TAVOLA
 DRAWING
 TABLE
 BILD
 TABLA

16

Note Notes Notes Marke Notas	Pos. No. N. Index Pos.	N. Cod. Code No. Nr. Code Code Nr N. Cod.	Q.tà Q.ty Q.te M.ge C.ad	DENOMINAZIONE	NAME	DESIGNATION	BESHREIBUNG	DENOMINACION
	1	8000H1462	1	GIRANTE POMPA ACQUA	IMPELLER, WATER PUMP	TURBINE POMPE A EAU	WASSERPUMPE LAUFSCHWUNGRAD	ROTOR BOMBA AGUA
	2	Z00056443	1	DADO FLANGIATO M5X0,8	NUT FLANGE M5X0.8	ECROU BRIDE M5X0,8	GEFLANSCHTE MUTTER M5X0,8	TUERCA CON REBORDE M5X0,8
	3	8000H1958	1	CORPO POMPA ACQUA	CASE, WATER PUMP	CORPS POMPE À EAU	GEHAEUSE, WASSERPUMPE	CAJA BOMBA AGUA
	4	8000A4789	1	ALBERO POMPA ACQUA	SHAFT, WATER PUMP	ARBRE POMPE A EAU	WELLE, WASSERPUMPE	ARBOL, BOMBA AGUA
	5	161795501	2	BOCCOLA 8X6,4X6	BUSH 8X6.4X6	DOUILLE 8X6,4X6	BUCHSE 8X6,4X6	CASQUILLO 8X6,4X6
	6	Z00062730	3	VITE TE M6X1X30 CH8	SCREW TE M6X1X30 CH8	VIS TE M6X1X30 CH8	SCHRAUBE TE M6X1X30 CH8	TORNILLO TE M6X1X30 CH8
	7	800027122	1	ANELLO O-RING 3237 60X2,62	O-RING 3237 60X2.62	JOINT TORIQUE 3237 60X2,62	O-RING 3237 60X2,62	JUNTA TORICA 3237 60X2,62
	8	800091565	1	FLANGIA SUPPORTO POMPA ACQUA	FLANGE, WATER PUMP	BRIDE POMPE A EAU	FLANSCH, WASSERPUMPE	BRIDA BOMBA AGUA
	9	800034317	1	CUSCINETTO A SFERE 12X28X8	BEARING, BALL 12X28X8	ROULEMENT A BILLES 12X28X8	KUGELLAGER 12X28X8	COJINETE DE BOLAS 12X28X8
	10	800053339	1	PARAOLIO 8X16X10	OIL SEAL 8X16X10	BAGUE D'ETANCHEITE 8X16X10	WELLENDICHRING 8X16X10	RETEN DE ACEITE 8X16X10
	11	800040007	1	ANELLO O-RING 2125	O-RING 2125	JOINT TORIQUE 2125	O-RING 2125	JUNTA TORICA 2125
	12	8A0099708	1	TUBO ACQUA TESTA POMPA	HOSE-COOLING CYLINDER HEAD PUMP	TUYAU EAU COULASSE POMPE	WASSERLEITUNG ZYLINDERKOPF PUMPE	MANGUERA AGUA CULATA BOMBA
	13	8B0099475	2	FASCETTA HOP 8-16/27 mm	CLAMP HOP 8-16/27 mm	COLLIER HOP 8-16/27 mm	SHELLE HOP 8-16/27 mm	ABRAZADERA HOP 8-16/27 mm
	14	F000P00022	1	RADIATORE SINISTRO	RADIATOR, LH	RADIATEUR GAUCHE	WASSERKUEHLER LINKS	RADIADOR IZQUERDO
	15	F000P00023	1	RADIATORE DESTRO	RADIATOR, RH	RADIATEUR DROIT	WASSERKUEHLER RECHTS	RADIADOR DERECHO
	16	8000A1281	1	TUBO SFIATO 660 mm	HOSE, BREATHER 660 mm	TUYAU RENIFLARD 660 mm	ENTLUEFTERSCHLAUCH 660 mm	MANGUERA RESPIRADERO 660 mm
	17	8000H1981	2	FASCETTA	CLAMP	COLLIER	KLAMMER	ABRAZADERA
	18	8000H1298	1	TUBO RACCORDO RADIATORI	HOSE JOINT, RADIATOR	TUYAU RACCORD RADIATEUR	KUEHLERVERBINDUNGS SCHLAUCH	TUBO EMPALME RADIADOR
	19	F000P00025	6	SILENTBLOCK RADIATORE	RUBBER, RADIATOR MOUNTING	CAOUTCHOUC MONTAGE RADIATEUR	SCHWINGUNGSDAEMPFER, KUEHLER	CASQUILLO ELASTICO RADIADOR
	20	8G0059802	5	BUSSOLA	BUSHING	DOUILLE	BUCHSE	CASQUILLO
	20	8H0059802	1	BUSSOLA RADIATORE SINISTRO	BUSHING	DOUILLE	BUCHSE	CASQUILLO
	21	Z00062729	6	VITE TEF M6X1X25	SCREW TEF M6X1X25	VIS TEF M6X1X25	SCHRAUBE TEF M6X1X25	TORNILLO TEF M6X1X25
	22	Z00059801	6	RONDELLA 22X6,5X1	WASHER 22X6.5X1	RONDELLE 22X6,5X1	SCHEIBE 22X6,5X1	ARANDELA 22X6,5X1
RS 500R - SM 500R	23	8000H1370	1	TUBO ACQUA POMPA RADIATORE	HOSE COOLING, PUMP COOLER	TUYAU EAU POMPE RADIATEUR	SCHLAUCH, WASSER PUMP-KUEHLER	MANGUITO AGUA BOMBA-RADIADOR
RS 300R	23	8000H1410	1	TUBO ACQUA POMPA RADIATORE	HOSE COOLING, PUMP COOLER	TUYAU EAU POMPE RADIATEUR	SCHLAUCH, WASSER PUMP-KUEHLER	MANGUITO AGUA BOMBA-RADIADOR
	24	800056444	1	FASCETTA 188 mm	CLAMP 188 mm	COLLIER 188 mm	SHELLE 188 mm	ABRAZADERA 188 mm
	25	8000A7715	1	ELETTROVENTOLA	BLOWER ASSY	ELECTRO-VENTILATEUR	ELEKTROLUEFTERRAD	ELECTROVENTILADOR
	26	F000P00685	1	SUPPORTO ELETTROVENTOLA	BRACKET ELECTRIC FAN	SUPPORT ELECTROVENTILATEUR	HALTER ELEKTROLUEFTER	SOPORTE VENTILADOR ELECTRICO
	27	F000P00117	1	TUBO ACQUA	HOSE, WATER	TUYAU EAU	SCHLAUCH, WASSER	MANGUERA AGUA
	28	F000P00116	1	TUBO ACQUA	HOSE, WATER	TUYAU EAU	SCHLAUCH, WASSER	MANGUERA AGUA
	29	8A0099475	4	FASCETTA HOP 8-12/22 mm	CLAMP HOP 8-12/22 mm	COLLIER HOP 8-12/22 mm	SHELLE HOP 8-12/22 mm	ABRAZADERA HOP 8-12/22 mm
	30	8B0099475	3	FASCETTA HOP 8-16/27 mm	CLAMP HOP 8-16/27 mm	COLLIER HOP 8-16/27 mm	SHELLE HOP 8-16/27 mm	ABRAZADERA HOP 8-16/27 mm
	31	60ND01030	4	VITE TE M4X0,7X25	SCREW TE M4X0.7X25	VIS TE M4X0,7X25	SCHRAUBE TE M4X0,7X25	TORNILLO TE M4X0,7X25

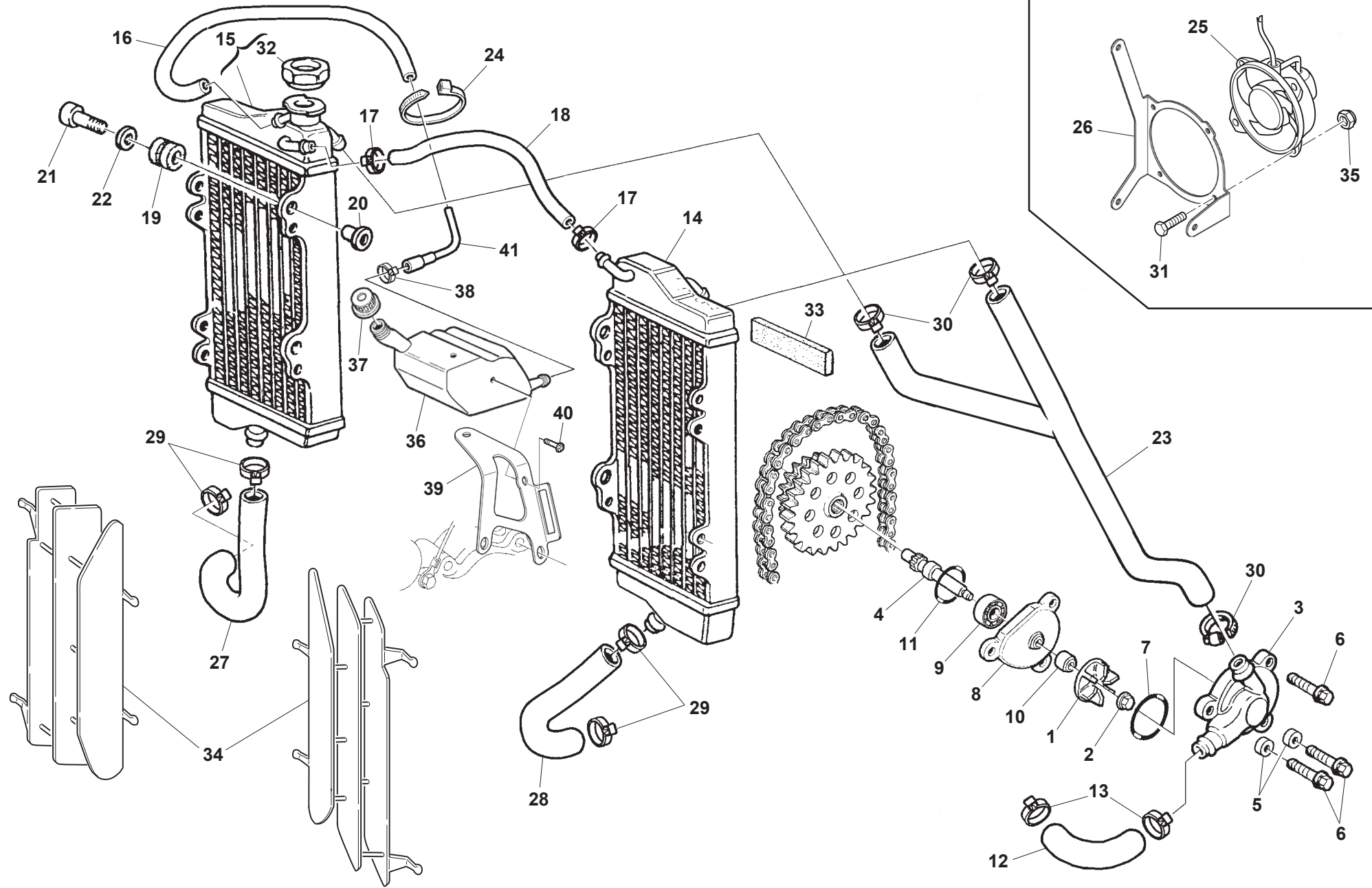

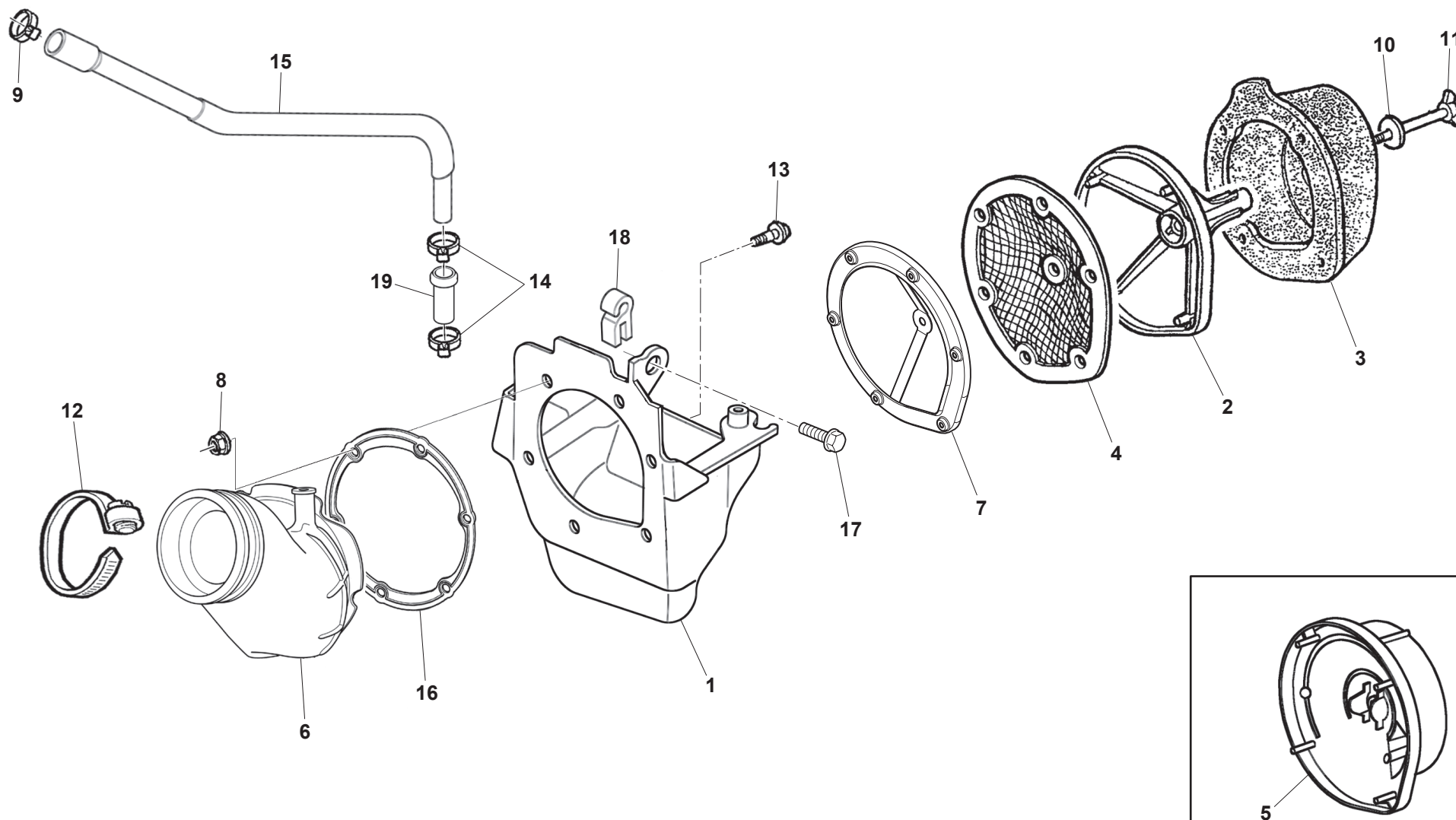



RS 300R/2016
RS 500R/2016
SM 500R/2016

FILTRO ARIA - AIR FILTER
FILTRE AIRE - LUFTFILTER
FILTRO DE AIRE

TAVOLA
 DRAWING
 TABLE
 BILD
 TABLA

17

Note Notes Marke Notas	Pos. No. Index Pos.	N. Cod. Code No. Nr. Code Code Nr N. Cod.	Q.tà Q.ty Q.te M.ge C.ad	DENOMINAZIONE	NAME	DESIGNATION	BESHREIBUNG	DENOMINACION
	1	8000H0054	1	CASSETTA FILTRO ARIA	CASE, AIR CLEANER	BOITE FILTRE A AIR	LUFTFILTERGEHAUSE	CAJA FILTRO AIRE
	2	800069549	1	GABBIA FILTRO ARIA	CAGE, AIR FILTER	CAGE FILTRE A AIR	LUFTFILTERKAEFIG	JAULA FILTRO AIRE
	3	800072641	1	FILTRO ARIA	FILTER, AIR	FILTRE A AIR	LUFTFILTER	FILTRO AIRE
	4	8000A0656	1	RETE PARAFIAMMA	ARRESTER, FLAME	RESEAU ANTIFLAMMES	FLAMMSCHUTZNETZ	RED ANTIFLAMA
	5	8000H0805	1	GABBIA FILTRO ARIA	CAGE, AIR FILTER	CAGE FILTRE A AIR	LUFTFILTERKAEFIG	JAULA FILTRO AIRE
	6	8000B0248	1	MANICOTTO CASSETTA FILTRO ARIA	TUBE, AIR CLEANER JOINT	RACCORD BOITE FILTRE A AIR	VERBINDUNGS, LUFTFILTERGEHAUSE	MANGUITO, CAJA FILTRO AIRE
	7	8000H3013	1	FLANGIA	FLANGE	BRIDE	FLANSCH	BRIDA
	8	Z00040718	6	DADO AUTOBLOCCANTE M5X0,8	NUT, SELF LOCKING M5X0.8	ECROU AUTOBLOQUANT M5X0,8	SELBSTSPERRENDE MUTTER M5X0,8	TUERCA AUTOBLOQUEANTE M5X0,8
	9	8A0092249	1	FASCETTA CLIC R 96-175 mm	HOSE CLAMP R 96-175 mm	COLLIER CLIC R 96-175 mm	SCHLAUCHSCHELLE R 96-175 mm	ABRAZADERA CLIC R 96-175 mm
	10	62ND15549	1	RONDELLA 18X6,4X1 mm	WASHER 18X6.4X1 mm	RONDELLE 18X6,4X1 mm	SCHEIBE 18X6,4X1 mm	ARANDELA 18X6,4X1 mm
	11	ZA0037947	1	VITE A FARFALLA M6X1	SCREW, WING M6X1	VIS A OREILLES M6X1	FLUEGELSCHRAUBE M6X1	TORNILLO MARIPOSA M6X1
	12	8E0099475	1	FASCETTA NEMO 40/80 mm	CLAMP NEMO 40/80 mm	COLLIER NEMO 40/80 mm	SCHELLE NEMO 40/80 mm	ABRAZADERA NEMO 40/80 mm
	13	8B00A8421	2	VITE FLANGIATA M5X16	SCREW M5X14	VIS M5X16	SCHRAUBE M5X16	TORNILLO M5X16
	14	8M0092249	2	FASCETTA CLIC R96 14,5 mm	CLAMP CLIC R96 14.5 mm	COLLIER CLIC R96 14,5 mm	KLAmMER CLIC R96 14,5 mm	ABRAZADERA CLIC R96 14,5 mm
	15	8000B0399	1	TUBO SFIATO	HOSE, BREATHER	TUYAU RENIFLARD	ENTLUEFTERSCHLAUCH	MANGUERA RESPIRADERO
	16	8000B0575	1	FLANGIA MANICOTTO CASSETTA FILTRO	HOLDER, GUIDE	PLAQUE AVANT BOITE FILTRE A AIR	PLATTE, LUFTFILTERGEHAUSE	PLATINA SOPORTE JAULA FILTRO INTERIOR
	17	8A00A8421	1	VITE FLANGIATA M5X12	BOLT, FLANGE M5X12	VIS A EMBASE M5X12	GEFLANSCHSCHRAUBE M5X12	TORNILLO CON VALONA M5X12
	18	800072494	1	MOLLETTA FERMACAPO	CLAMP, WIRE	COLLIER, CORDON	KABELBINDER	GRAMPA CORDON
	19	8000A8999	1	RACCORDO SFIATO	JOINT, BREATHER	RACCORD, RENIFLARD	ANSCHLUSS, BELUFTUNG	RACOR RESPIRADERO

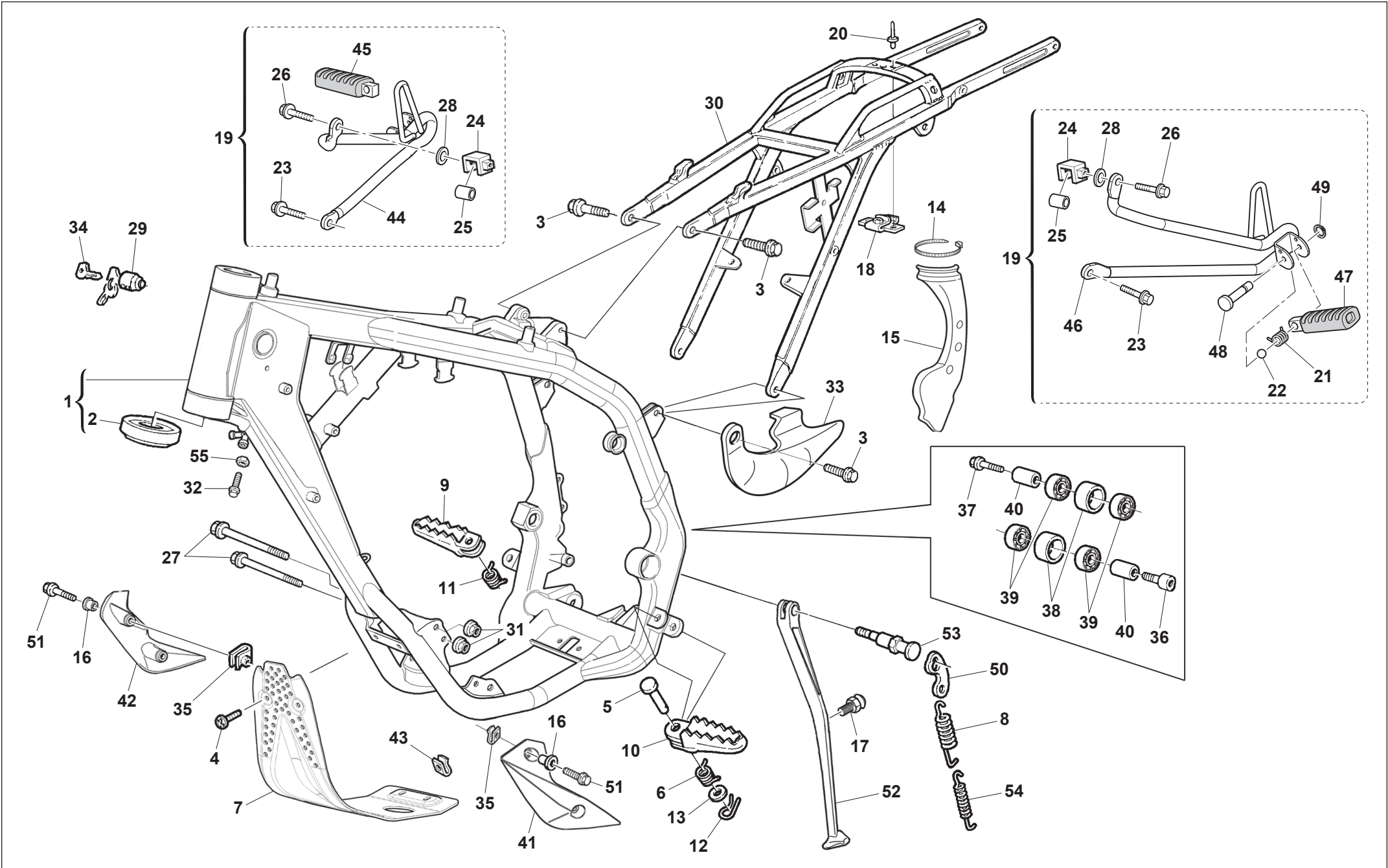



RS 300R/2016
RS 500R/2016
SM 500R/2016

TELAIO, PEDANE - FRAME, FOOT RESTS
CADRE, REPOSE PIEDS - RAHMEN, FUSSBRETT
BASTIDOR, REPOSAPIES

TAVOLA
 DRAWING
 TABLE
 BILD
 TABLA

18

Note Notes Notes Marke Notas	Pos. No. N. Index Pos.	N. Cod. Code No. Nr. Code Code Nr N. Cod.	Q.tà Q.ty Q.te M.ge C.ad	DENOMINAZIONE	NAME	DESIGNATION	BESHREIBUNG	DENOMINACION
	1	F000A01107	1	TELAIO	FRAME	CADRE	RAHMEN	BASTIDOR
	2	800087243	2	CUSCINETTO A RULLI CONICI 29-48-17,5	CONICAL ROLLERS BEARING 29-48-17.5	ROULEMENT A ROULEAUX CONIQUES 29-48-17,5	KEGELROLLENLAGER 29-48-17,5	COJINETE DE RODILLOS CONICO 29-48-17,5
	3	Z00069056	4	VITE TE M8X1,25X20 CH12	SCREW TE M8X1.25X20 CH12	VIS TE M8X1,25X20 CH12	SCHRAUBE TE M8X1,25X20 CH12	TORNILLO TE M8X1,25X20 CH12
	4	Y00060898	4	VITE TTEI M6X1X15 CH5	SCREW TTEI M6X1X15 CH5	VIS TTEI M6X1X15 CH5	SCHRAUBE TTEI M6X1X15 CH5	TORNILLO TTEI M6X1X15 CH5
	5	Y00073140	2	PERNO CLEVIS	PIN, CLEVIS	BOULON, A GOUPILLE	LASTOSENSTIFT	PASADOR CON HOYO
	6	800096907	1	MOLLA PEDANA SINISTRA	SPRING, FOOTREST LH	RESSORT REPOSE-PIEDS GAUCHE	FEDER, FUSSRASTE LINKS	MUELLE ESTRIBO IZQUERDO
	7	8000B0157	1	PARAMOTORE	GUARD, ENGINE	PROTECTION MOTEUR	SCHUTZ, MOTOR	PROTECCION MOTOR
	8	8000A0269	1	MOLLA CAVALLETTO LATERALE ESTERNA	SPRING SIDE STAND OUTER	RESSORT EXTERIEUR BEQUILLE LATERALE	AUSSEREFEDER, SEITENSTAENDER	MUELLE EXTERIOR CABALLETE LATERAL
	9	80A089953	1	PEDANA ANTERIORE DESTRA	FOOTREST, FRONT RH	REPOSE-PIEDS AVANT DROIT	VORNE FUSSRASTE, RECHTS	ESTRIBO DELANTERO DERECHO
	10	80A089962	1	PEDANA ANTERIORE SINISTRA	FOOTREST, FRONT LH	REPOSE-PIEDS AVANT GAUCHE	VERDER FUSSRASTE LINKS	ESTRIBO DELANTERO IZQUERDO
	11	800096908	1	MOLLA PEDANA DESTRA	SPRING, FOOTREST, RH	RESSORT REPOSE-PIEDS DROIT	FEDER, FUSSRASTE RECHTS	MUELLE ESTRIBO DERECHO
	12	64ND20068	2	COPIGLIA 1,8X18	PIN, COTTER 1.8X18	GOUPILLE FENDUE 1,8X18	SPLINT 1,8X18	GRUPILLA 1,8X18
	13	ZA0001815	2	RONDELLA 16X10X1	WASHER 16X10X1	RONDELLE 16X10X1	SCHEIBE 16X10X1	ARANDELA 16X10X1
	14	800056444	1	FASCETTA 188 mm	CLAMP 188 mm	COLLIER 188 mm	SCHELLE 188 mm	ABRAZADERA 188 mm
	15	8000H3435	1	PROTEZIONE TELAIO SINISTRA	GUARD, FRAME LH	PROTECTION CADRE GAUCHE	RAHMENSCHUTZ LINKS	PROTECCION BASTIDOR IZQUERDA
	16	8000H0822	4	BOCCOLA	BUSH	DOUILLE	BUCHSE	BUJE
	17	8000H0235	1	PERNO PORTAMOLLE CAVALLETTO	PIN SPRING	GOUJON RESSORT	BOLZEN, FEDER	PERNO MUELLE
	18	800069150	1	PIASTRINA ATTACCO SELLA	BRACKET, SEAT	SUPPORT SELLE	KONSOLE, SITZBANK	SOPORTE ASIENITO
	19	F000A00565	1	KIT PEDANE PASSEGGERO	FOOTREST BRACKET KIT	GROUPE SUPPORT REPOSE PIEDS	FUSSRAESTERGRUPPE	GRUPO APOYAPIE TRASERO
	20	800033373	2	RIVETTO A STRAPPO 3,3X14	SHEAR RIVET 3.3X14	RIVET ARRACHAGE 3,3X14	REISSNIETE 3,3X14	REMACHE A DESGARRE 3,3X14
	21	800062655	2	MOLLA	SPRING	RESSORT	FEDER	MUELLE
	22	6BN021507	2	SFERA ACCIAIO D1/4"	STEEL BALL D1/4"	BILLE D1/4"	KUGEL D1/4"	BOLA D1/4"
	23	8000B1959	2	VITE TEF M8X1,25X25 CH12	SCREW TEF M8X1.25X25 CH12	VIS TEF M8X1,25X25 CH12	SCHRAUBE TEF M8X1,25X25 CH12	TORNILLO TEF M8X1,25X25 CH12
	24	8000A7237	2	CAVALLOTTO	U-BOLT	CAVALIER	BUEGELBOLZEN	PUNTE
	25	800024350	2	DISTANZIALE 18X8,5X19	SPACER 18X8.5X19	ENTRETOISE 18X8,5X19	ABSTANDHALTER 18X8,5X19	DISTANCIADOR 18X8,5X19
	26	8E00B1959	4	VITE TEF M8X1,25X40 CH12	SCREW TEF M8X1.25X40 CH12	VIS TEF M8X1,25X40 CH12	SCHRAUBE TEF M8X1,25X40 CH12	TORNILLO TEF M8X1,25X40 CH12
	27	YG0073458	2	VITE M8X150	SCREW M8X150	VIS M8X150	SCHRAUBE M8X150	TORNILLO
	28	F000P00917	2	RONDELLA	WASHER	RONDELLE	SCHEIBE	ARANDELA 16X10X1
	29	800043391	1	SERRATURA BLOCCASTERZO	LOCK, STEERING	ANTIVOL DIRECTION	SCHLOSS, LENKER	CARRADURA MANILLAR
	30	F000A00271	1	TELAIO POSTERIORE	REAR FRAME	CADRE ARRIERE	HINTERER RAHMEN	BASTIDOR TRASERO
	31	Y00043928	3	DADO AUTOBLOCCANTE M8X1,25	NUT, SELF LOCKING M8X1.25	ECROU AUTOBLOQUANT M8X1,25	SELBSTSPERRENDE MUTTER M8X1,25	TUERCA AUTOBLOQUEANTE M8X1,25
	32	ZE0061121	2	VITE M8X30	SCREW M8X30	VIS M8X30	SCHRAUBE M8X30	TORNILLO M8X30
	33	8000B1747	1	ISOLANTE TERMICO	INSULATOR, HEAT	ISOLATEUR THERMIQUE	WAERMESCHUTZ	AISILANTE ATERMICO

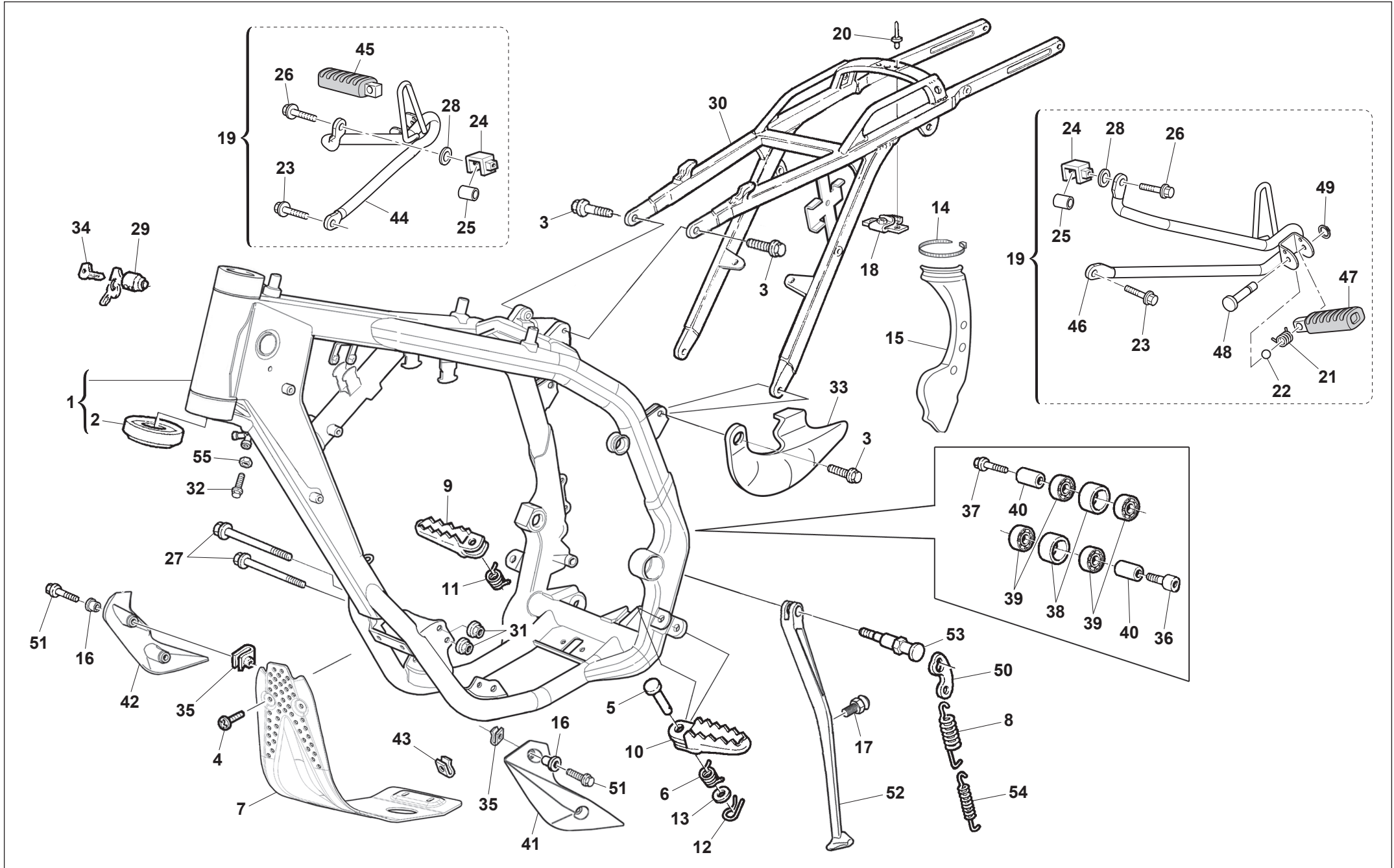

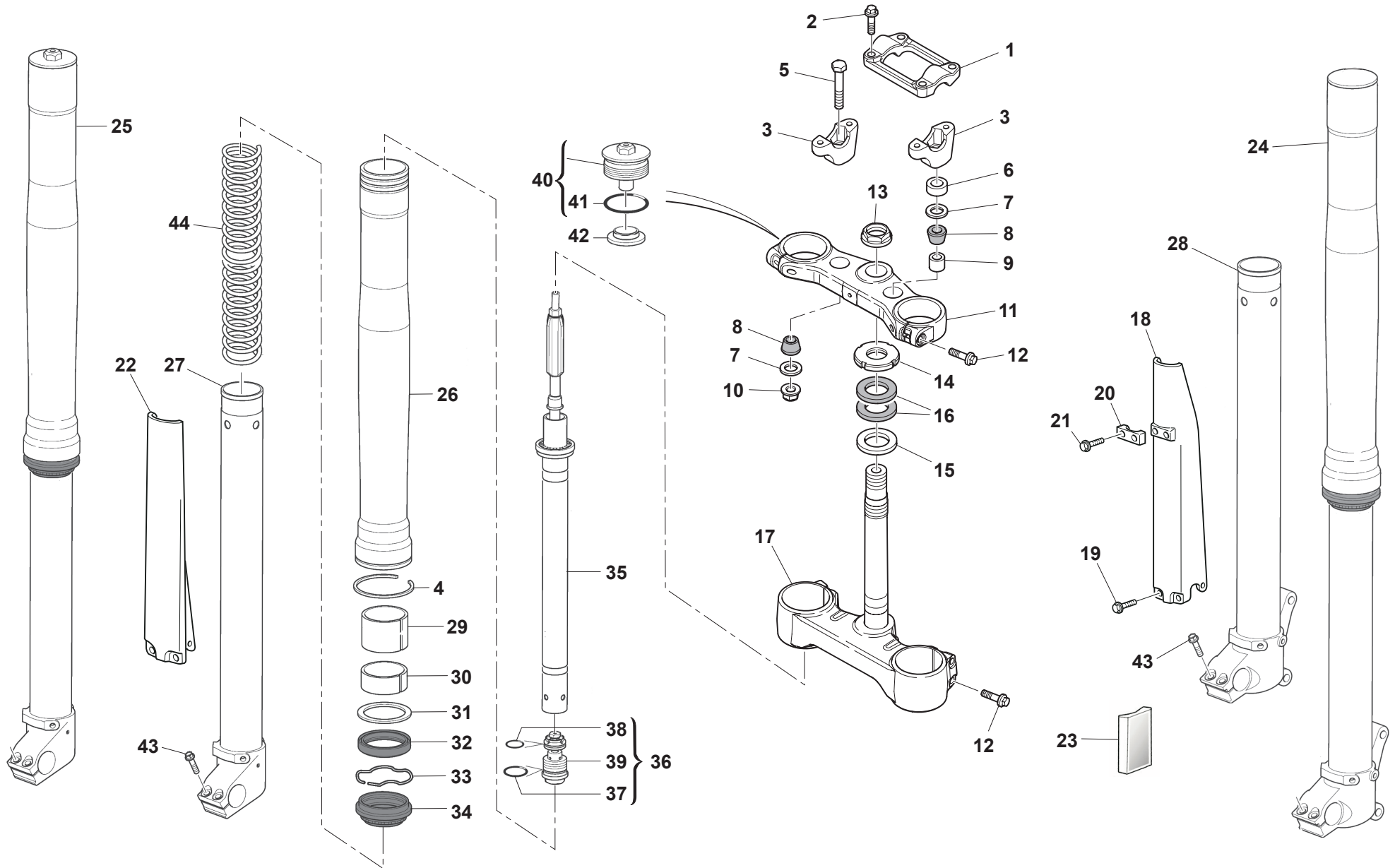



RS 300R/2016
RS 500R/2016

SOSPENSIONE ANTERIORE - FRONT FORK ASSEMBLY
SUSPENSION AVANT - VORDERTELESKOPGABEL
SUSPENSION DELANTERA

TAVOLA
DRAWING
TABLE
BILD
TABLA

19

Note Notes Notas	Pos. No. N. Index Pos.	N. Cod. Code No. Nr. Code Code Nr N. Cod.	Q.tà Q.ty Q.te M.ge C.ad	DENOMINAZIONE	NAME	DESIGNATION	BESHREIBUNG	DENOMINACION
	1	8000B0522	1	CAVALLOTTO MANUBRIO SUPERIORE	HANDLEBAR BRACKET, UPPER	BRIDE GUIDON, SUPERIEURE	LENKER BUEGELBOLZEN, OBERE	PUENTE MANILLAR, SUPERIOR
	2	8A00B1959	4	VITE TEF M8X1,25X25 CH10	SCREW TEF M8X1,25X25 CH10	VIS TEF M8X1,25X25 CH10	SCHRAUBE TEF M8X1,25X25 CH10	TORNILLO TEF M8X1,25X25 CH10
	3	8000H2355	2	CAVALLOTTO MANUBRIO INFERIORE	HANDLEBAR BRACKET	BRIDE GUIDON, INFERIEUR	LENKER BUEGELBOLZEN, UNTEN	PUENTE MANILLAR, INFERIOR
	4	8000H2672	2	ANELLO DI FERMO	RING, STOPPER	BAGUE ARRET	STOPRING	ANILLO TOPE
	5	60ND01222	2	VITE TE M10X1,5X8	SCREW TE M10X1,5X8	VIS TE M10X1,5X8	SCHRAUBE TE M10X1,5X8	TORNILLO TE M10X1,5X8
	6	8A00A6683	2	DISTANZIALE 32X10X13,5 mm	SPACER 32X10X13,5 mm	ENTRETOISE 32X10X13,5 mm	ABSTANDHALTER 32X10X13,5 mm	DISTANCIADOR 32X10X13,5 mm
	7	800060234	4	RONDELLA 28X22X10,5X2,5 mm	WASHER 28X22X10,5X2,5 mm	RONDELLE 28X22X10,5X2,5 mm	SCHEIBE 28X22X10,5X2,5 mm	ARANDELA 28X22X10,5X2,5 mm
	8	8000H1385	4	SILENTBLOCK	DAMPER	SILENTBLOC	SCHWINGUNGSDAEMPFER	CASQUILLO ELASTICO
	9	8000H1714	2	DISTANZIALE 12X10 mm	SPACER 12X10 mm	ENTRETOISE 12X10 mm	ABSTANDHALTER 12X10 mm	DISTANCIADOR 12X10 mm
	10	Z00061314	2	DADO AUTOBLOCCANTE M10X1,5	NUT, SELF LOCKING M10X1,5	ECROU AUTOBLOQUANT M10X1,5	SELBSTSPERRENDE MUTTE M10X1,5	TUERCA AUTOBLOQUEANTE M10X1,5
	11	F000P00164	1	PIASTRA FORCELLA SUPERIORE	HEAD, STEERING STEM	TETE DIRECTION	GABELKOPF	TIJA SUPERIOR
	12	8E00B1959	6	VITE TEF M8X1,25X40 CH12	SCREW TEF M8X1,25X40 CH12	VIS TEF M8X1,25X40 CH12	SCHRAUBE TEF M8X1,25X40 CH12	TORNILLO TEF M8X1,25X40 CH12
	13	8A0069315	1	DADO CANNOTTO M26X1 CH30	NUT, STEERING STEM M26X1 CH30	ECROU FOURCHE M26X1 CH30	GABELMUTTER M26X1 CH30	TUERCA HORQUILLA M26X1 CH30
	14	8A0087717	1	GHIERA CANNOTTO STERZO	BOLT STEERING HEAD TOP	ECROU SUPERIEUR TETE DIRECTION	OBER-GEWINDE, STEUERKOPF	TUERCA SUPERIOR CABEZAL DIRECCION
	15	800087736	1	RONDELLA 40,5X29,5X2	WASHER 40,5X29,5X2	RONDELLE 40,5X29,5X2	SCHEIBE 40,5X29,5X2	ARANDELA PLANA 40,5X29,5X2
	16	800087745	2	GUARNIZIONE	GASKET	JOINT	DICHTUNG	JUNTA
	17	F000P00166	1	PIASTRA FORCELLA INFERIORE	STEM, STEERING	SOCLE DIRECTION	GABELBRUECKE, UNTEN	BASE DIRECCION
	18	80D0A8481	1	PROTEZIONE STELO FORCELLA SINISTRO	GUARD FORK TUBE, LH	PROTECTION TIGE FOURCHE GAUCHE	GABELSTANGENSCHUTZ LINKS	PROTECCION VARILLA IZQUERDA
	19	8000A8423	6	VITE FLANGIATA M6X8	BOLT, FLANGE M6X8	VIS A EMBASE M6X8	GEFLANSCHSCHRAUBE M6X8	TORNILLO CON VALONA M6X8
	20	80D0A0633	1	FERMACAVO	CLAMP, WIRE	COLLIER, CORDON	KABELKLEMME	GRAMPA CORDON
	21	ZA0084658	2	VITE AUTOFILETTANTE	SCREW, TAPPING	VIS TARAUD	GEWINDESCHRAUBE	TORNILLO AUTOROSCANTE
	22	80D0A8482	1	PROTEZIONE STELO FORCELLA DESTRO	GUARD FORK TUBE, RH	PROTECTION TIGE FOURCHE DROITE	GABELSTANGENSCHUTZ RECHTS	PROTECCION VARILLA DERECHA
	23	800074842	1	CATADIOTTRO LATERALE	REFLEX REFLECTOR, SIDE	CATADIOPTRÉ LATERAL	SEITENRUECKSTRAHLER	CATAFARO LATERAL
	24	8000H1399	1	GAMBA FORCELLA SINISTRA	FRONT CUSHION ASSY LEFT	JAMBE FOURCHE GAUCHE	GABELBEIN, LINKS	PIERNA HORQUILLA IZQUERDA
	25	8000H1400	1	GAMBA FORCELLA DESTRA	FRONT CUSHION ASSY RIGHT	JAMBE FOURCHE DROITE	GABELBEIN, RECHTS	PIERNA HORQUILLA DERECHA
	26	F000P00985	2	FODERO FORCELLA	FORK OUTER TUBE	FOURREAU FOURCHE	GABEL HUELSE	FUNDA HORQUILLA
	27	F000P00984	1	STELO FORCELLA DESTRO	FORK INNER TUBE RH	TIGE FOURCHE DROITE	GABELSTANGE, RECHTS	CANA HORQUILLA DERECHO
	28	F000P00992	1	STELO FORCELLA SINISTRO	FORK INNER TUBE LH	TIGE FOURCHE GAUCHE	GABELSTANGE, LINKS	CANA HORQUILLA IZQUERDO
	29	8000H2659	2	BOCCOLA SCORRIMENTO	BUSHING-FRONT FORK, SLIDE	DOUILLE COULISSEMENT	GLEITBUCHSE	CASQUILLO DESLIZAMIENTO
	30	8000H2660	2	BOCCOLA SCORRIMENTO	BUSHING-FRONT FORK, SLIDE	DOUILLE COULISSEMENT	GLEITBUCHSE	CASQUILLO DESLIZAMIENTO
	31	8000H2661	2	RONDELLA	WASHER	RONDELLE	SCHEIBE	ARANDELA
	32	8000H2662	2	PARAOILIO FORCELLA	SEAL OIL, FORK	BAGUE D'ETANCHEITE, FOURCHE	GABELDICHTRING	RETEN ACEITE, HORQUILLA
	33	8000H2663	2	ANELLO DI FERMO	RING, STOPPER	BAGUE ARRET	STOPRING	ANILLO TOPE

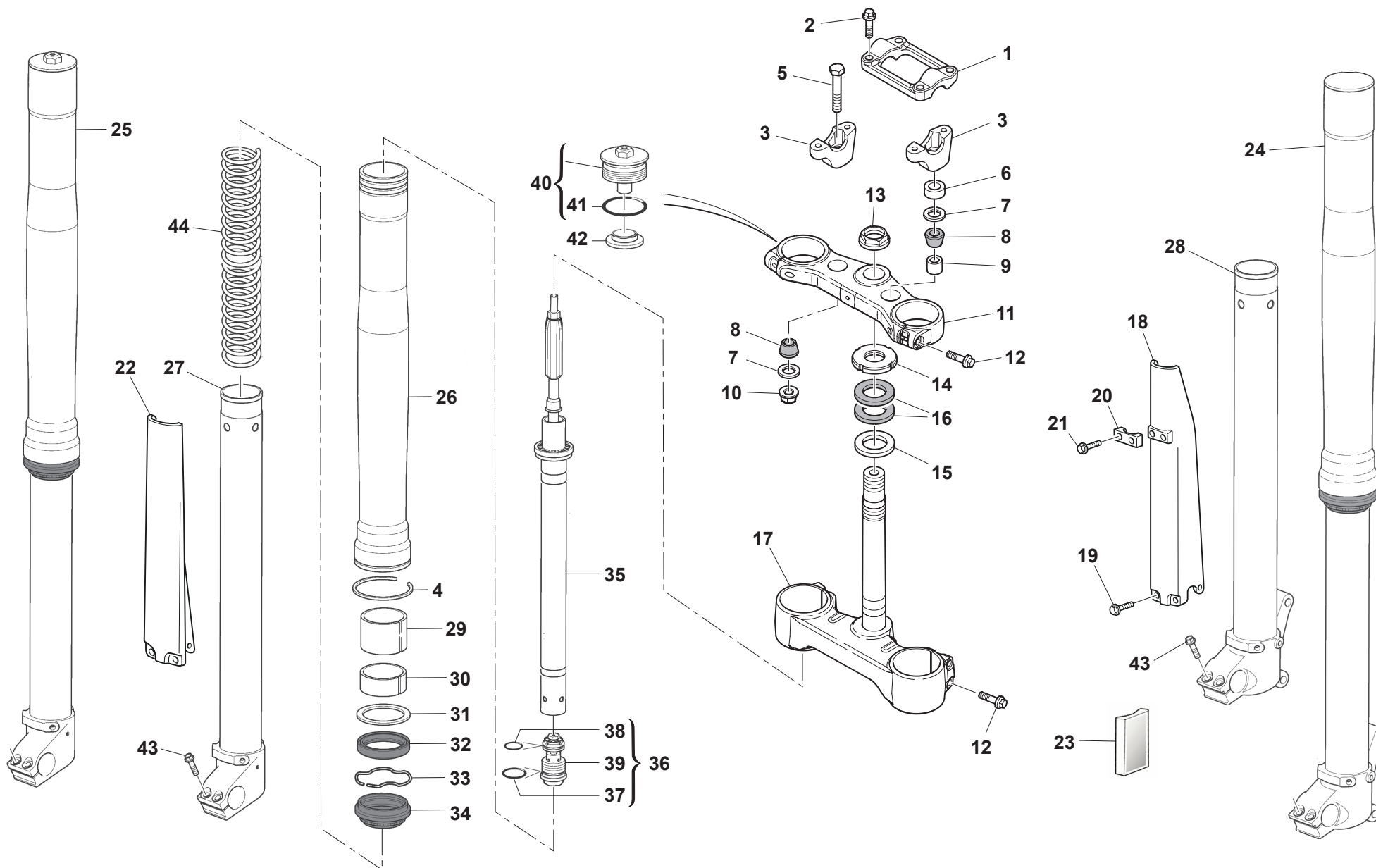

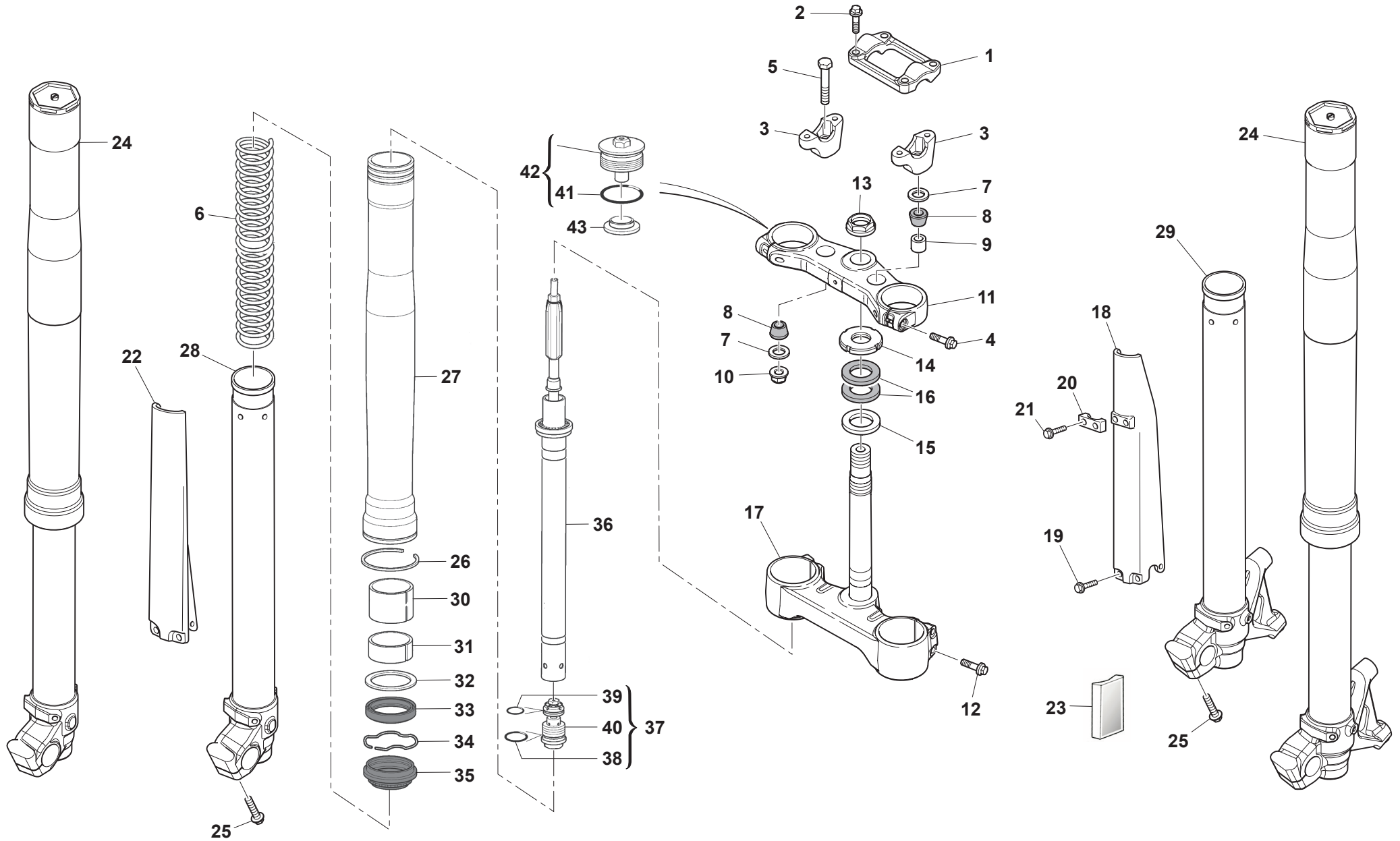



SM 500R/2016

SOSPENSIONE ANTERIORE - FRONT FORK ASSEMBLY SUSPENSION AVANT - VORDERTELESKOPGABEL SUSPENSION DELANTERA

TAVOLA
DRAWING
TABLE
BILD
TABLA

19A

Note Notes Notes Marke Notas	Pos. No. N. Index Pos.	N. Cod. Code No. Nr. Code Code Nr N. Cod.	Q.tà Q.ty Q.te M.ge C.ad	DENOMINAZIONE	NAME	DESIGNATION	BESHREIBUNG	DENOMINACION
	1	8000B0522	1	CAVALLOTTO MANUBRIO SUPERIORE	HANDLEBAR BRACKET, UPPER	BRIDE GUIDON, SUPERIEURE	LENKER BUEGELBOLZEN, OBERE	PUENTE MANILLAR, SUPERIOR
	2	8A00B1959	4	VITE TEF M8X1,25X30 CH10	SCREW TEF M8X1.25X30 CH10	VIS TEF M8X1,25X30 CH10	SCHRAUBE TEF M8X1,25X30 CH10	TORNILLO TEF M8X1,25X30 CH10
	3	8000H2355	2	CAVALLOTTO MANUBRIO INFERIORE	HANDLEBAR BRACKET, LOWER	BRIDE GUIDON, INFERIEUR	LENKER BUEGELBOLZEN, UNTEN	PUENTE MANILLAR, INFERIOR
	4	8E00B1959	2	VITE TEF M8X1,25X40 CH12	SCREW TEF M8X1.25X40 CH12	VIS TEF M8X1,25X40 CH12	SCHRAUBE TEF M8X1,25X40 CH12	TORNILLO TEF M8X1,25X40 CH12
	5	60ND01219	2	VITE TE M10X1,5X65	SCREW TE M10X1.5X65	VIS TE M10X1,5X65	SCHRAUBE TE M10X1,5X65	TORNILLO TE M10X1,5X65
	6	F000P00990	2	MOLLA FORCELLA K=5,0 N/mm	SPRING, FRONT FORK K=5.0 N/mm	RESSORT FOURCHE K=5,0 N/mm	FEDER,VORDERRADGABEL K=5,0 N/mm	MUELLE HORQUILLA K=5,0 N/mm
	7	800060234	4	RONDELLA 28X22X10,5X2,5 mm	WASHER 28X22X10.5X2.5 mm	RONDELLE 28X22X10,5X2,5 mm	SCHEIBE 28X22X10,5X2,5 mm	ARANDELA 28X22X10,5X2,5 mm
	8	8000H1385	4	SILENTBLOCK	DAMPER	SILENTBLOC	SCHWINGUNGSDAEMPFER	CASQUILLO ELASTICO
	9	8000H1714	2	DISTANZIALE 12X10 mm	SPACER 12X10 mm	ENTRETOISE 12X10 mm	ABSTANDHALTER 12X10 mm	DISTANCIADOR 12X10 mm
	10	Z00061314	2	DADO AUTOBLOCCANTE M10X1,5	NUT, SELF LOCKING M10X1.5	ECROU AUTOBLOQUANT M10X1,5	SELBSTSPERRENDE MUTTE M10X1,5	TUERCA AUTOBLOQUEANTE M10X1,5
	11	F000P00164	1	PIASTRA FORCELLA SUPERIORE	HEAD, STEERING STEM	TETE DIRECTION	GABELKOPF	TIJA SUPERIOR
	12	8E00B1959	4	VITE TEF M8X1,25X40 CH12	SCREW TEF M8X1.25X40 CH12	VIS TEF M8X1,25X40 CH12	SCHRAUBE TEF M8X1,25X40 CH12	TORNILLO TEF M8X1,25X40 CH12
	13	8A0069315	1	DADO CANNOTTO M26X1 CH30	NUT, STEERING STEM M26X1 CH30	ECROU FOURCHE M26X1 CH30	GABELMUTTER M26X1 CH30	TUERCA HORQUILLA M26X1 CH30
	14	8A0087717	1	GHIERA CANNOTTO STERZO	BOLT STEERING HEAD TOP	ECROU SUPERIEUR TETE DIRECTION	OBER-GEWINDE, STEUERKOPF	TUERCA SUPERIOR CABEZAL DIRECCION
	15	800087736	1	RONDELLA 40,5X29,5X2	WASHER 40.5X29.5X2	RONDELLE 40,5X29,5X2	SCHEIBE 40,5X29,5X2	ARANDELA PLANA 40,5X29,5X2
	16	800087745	2	GUARNIZIONE	GASKET	JOINT	DICHTUNG	JUNTA
	17	FA00P00166	1	PIASTRA FORCELLA INFERIORE	STEM, STEERING	SOCLE DIRECTION	GABELBRUECKE, UNTEN	BASE DIRECCION
	18	80D0A8481	1	PROTEZIONE STELO FORCELLA SINISTRO	GUARD FORK TUBE, LH	PROTECTION TIGE FOURCHE GAUCHE	GABELSTANGENSCHUTZ LINKS	PROTECCION VARILLA IZQUERDA
	19	8000A8423	6	VITE FLANGIATA M6X8	BOLT, FLANGE M6X8	VIS A EMBASE M6X8	GEFLANSCHSCHRAUBE M6X8	TORNILLO CON VALONA M6X8
	20	80D0A0633	1	FERMACAVO	CLAMP, WIRE	COLLIER, CORDON	KABELKLEMMME	GRAMPA CORDON
	21	ZA0084658	2	VITE AUTOFIETTANTE	SELF-TAPPING SCREW	VIS AUTOTARAUEUSE	BLECHSCHRAUBE	TORNILLO AUTORROSCANTE
	22	80D0A8482	1	PROTEZIONE STELO FORCELLA DESTRO	GUARD FORK TUBE, RH	PROTECTION TIGE FOURCHE DROITE	GABELSTANGENSCHUTZ RECHTS	PROTECCION VARILLA DERECHA
AUS	23	800074842	2	CATADIOTTRO LATERALE	REFLEX REFLECTOR, SIDE	CATADIOPRE LATERAL	SEITENRUECKSTRAHLER	CATAFARO LATERAL
	24	8000H1048	1	ASSIEME GAMBE FORCELLA	FRONT CUSHION ASSY	JAMBE FOURCHE COMPLETE	GABELBEIN KOMPL	PIERNA HORQUILLA COMPLETA
	25	8000H2671	4	VITE	SCREW	VIS	SCHRAUBE	TORNILLO
	26	8000H2672	2	ANELLO DI FERMO	RETAINING RING	BAGUE D'ARRÊT	SICHERUNGSRING	ANILLO DE RETENCIÓN
	27	F000P00985	2	FODERO FORCELLA	FORK OUTER TUBE	FOURREAU FOURCHE	GABEL HUELSE	FUNDA HORQUILLA
	28	F000P00986	1	STELO FORCELLA DESTRO	FORK INNER TUBE RH	TIGE FOURCHE DROITE	GABELSTANGE, RECHTS	CANA HORQUILLA DERECHO
	29	F000P00987	1	STELO FORCELLA SINISTRO	FORK INNER TUBE LH	TIGE FOURCHE GAUCHE	GABELSTANGE, LINKS	CANA HORQUILLA IZQUERDO
	30	8000H2659	2	BOCCOLA SCORRIMENTO	BUSHING-FRONT FORK, SLIDE	DOUILLE COULISSEMENT	GLEITBUCHSE	CASQUILLO DESLIZAMIENTO
	31	8000H2660	2	BOCCOLA SCORRIMENTO	BUSHING-FRONT FORK, SLIDE	DOUILLE COULISSEMENT	GLEITBUCHSE	CASQUILLO DESLIZAMIENTO
	32	8000H2661	2	RONDELLA	WASHER	RONDELLE	UNTERLEGSCHIEBE	ARANDELA
	33	8000H2662	2	PARAOLIO FORCELLA	SEAL OIL, FORK	BAGUE D'ETANCHEITE, FOURCHE	GABELDICHTRING	RETEN ACEITE, HORQUILLA

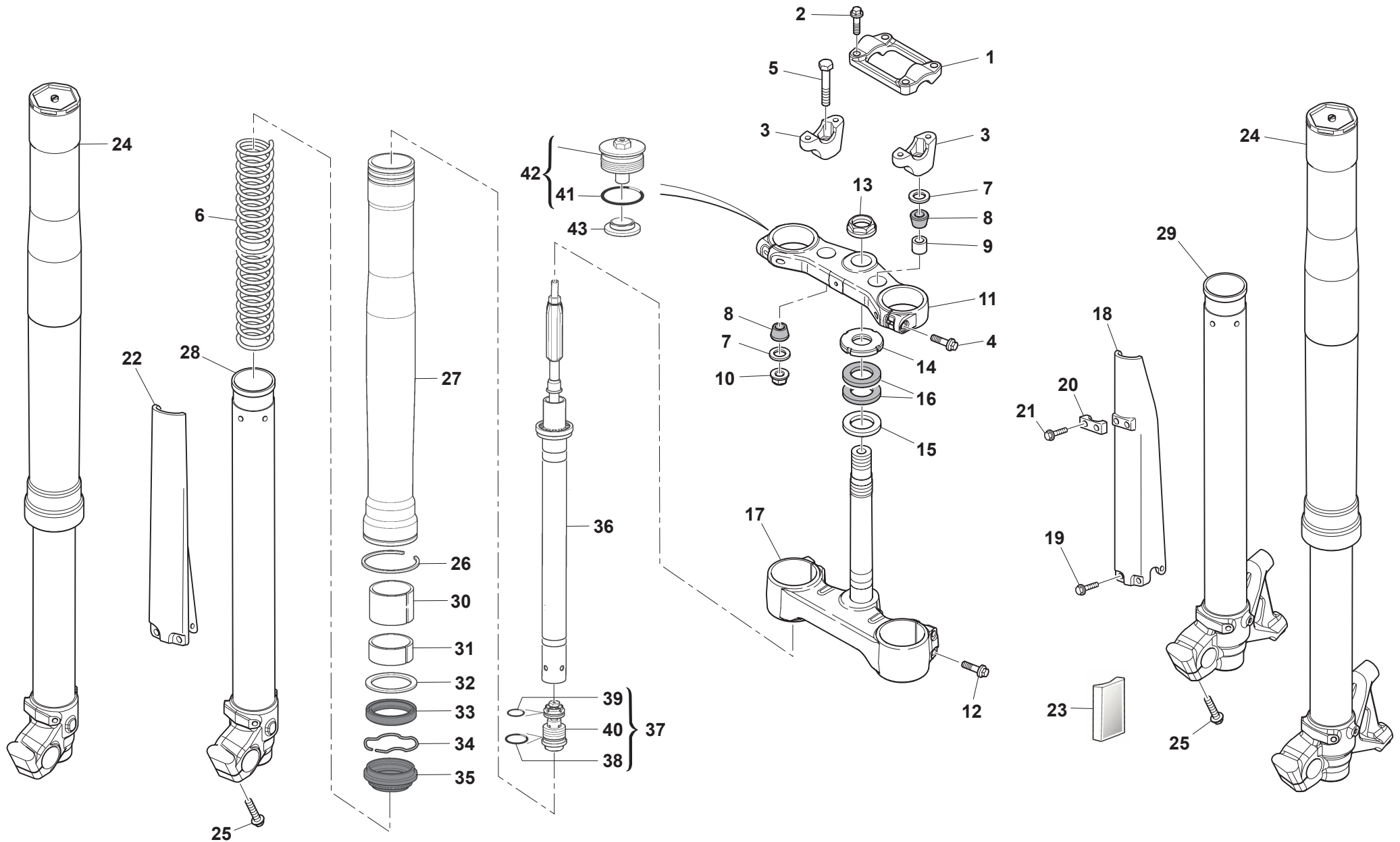

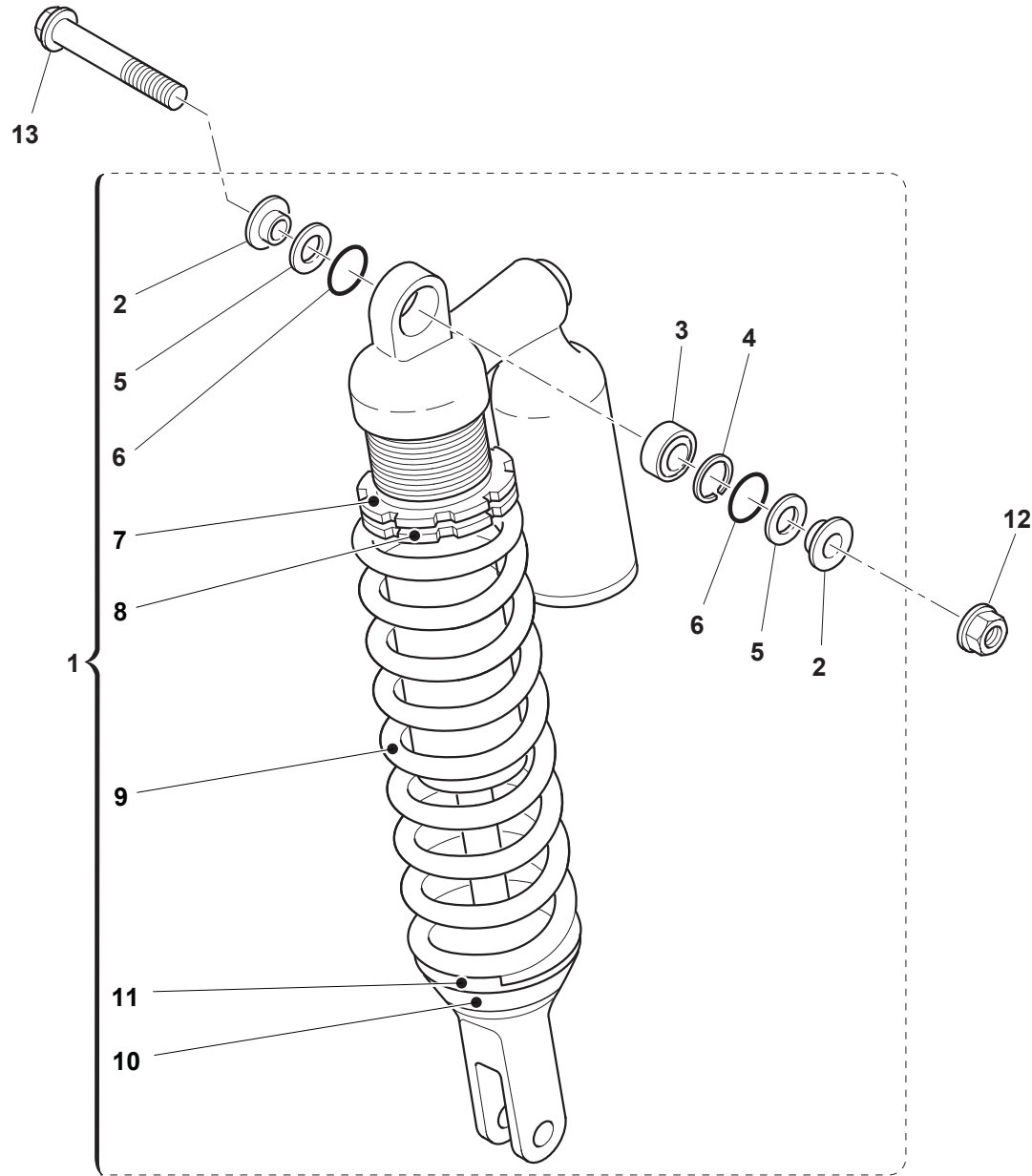

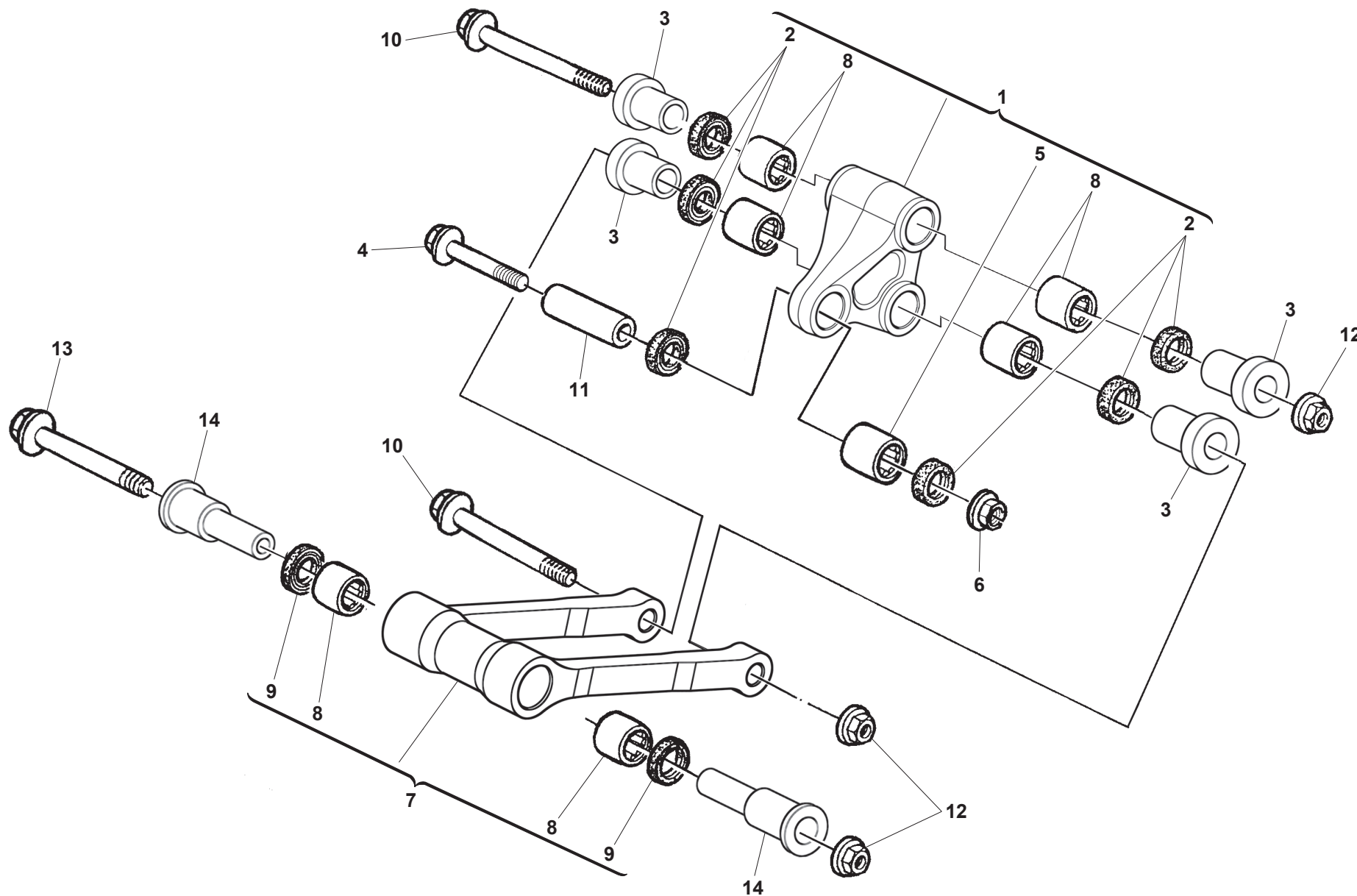

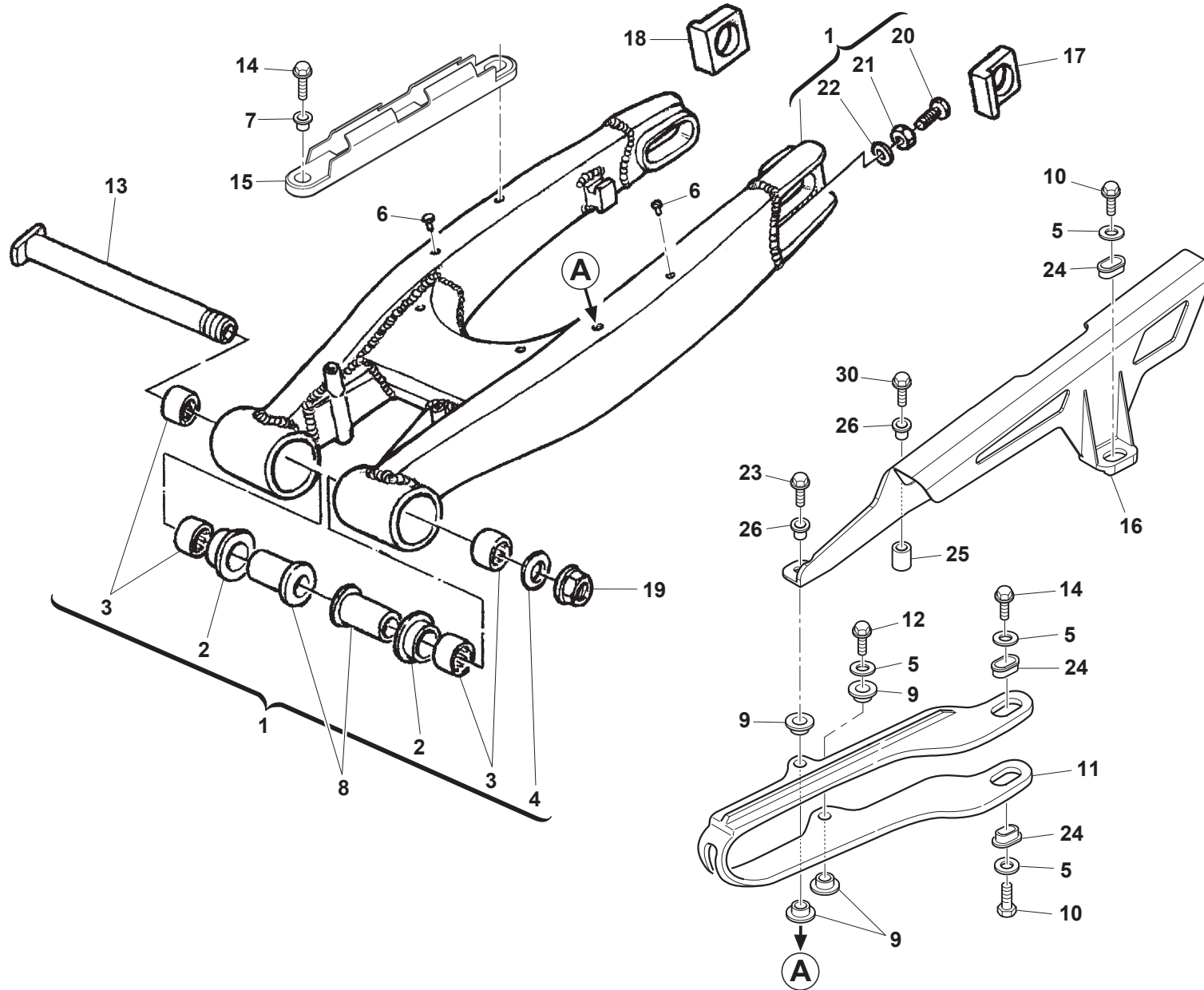

RS 300R - RS 500R

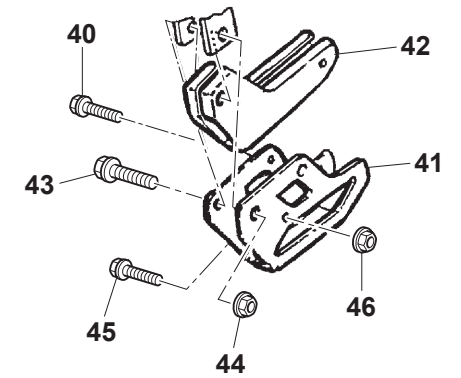

SM 500R

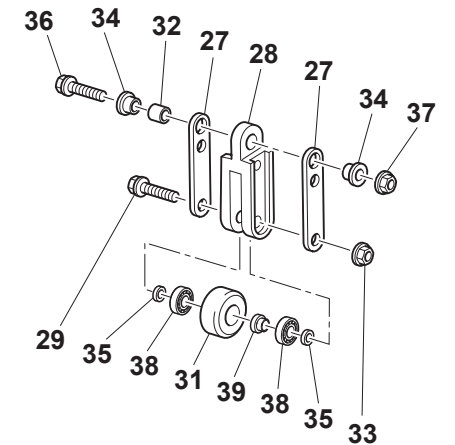



RS 300R/2016
RS 500R/2016
SM 500R/2016

FORCELLONE POSTERIORE - REAR SWING ARM
FOURCHE ARRIERE - HINTERGABEL
HORQUILLA TRASERA

TAVOLA
DRAWING
TABLE
BILD
TABLA

22

Note Notes Notes Marke Notas	Pos. No. N. Index Pos.	N. Cod. Code No. Nr. Code Code Nr N. Cod.	Q.tà Q.ty Q.te M.ge C.ad	DENOMINAZIONE	NAME	DESIGNATION	BESHREIBUNG	DENOMINACION
	1	8000H0680	1	FORCELLONE	REAR SWING ARM ASSY	BRAS OSCILLANT	HINTERE SCHWINGARM	BASCULANTE
	2	Z00071622	2	BOCCOLA FORCELLONE	BUSHING, SWING ARM	DOUILLE, BRAS OSCILLANT	HULSE, SCHWINGE	COLLAR BASCULANTE
	3	800076283	4	GABBIA A RULLI 22X28X11	BEARING, NEEDLE 22X28X11	ROULEMENT A AIGUILLES 22X28X11	NADELLAGER 22X28X11	COJINETE DE AGUJAS 22X28X11
	4	800032388	1	RONDELLA 26X17,2X1,5	WASHER 26X17.2X1.5	RONDELLE 26X17,2X1,5	SCHEIBE 26X17,2X1,5	ARANDELA 26X17,2X1,5
	5	Z00036137	4	RONDELLA 11X5,5X1,5	WASHER 11X5.5X1.5	RONDELLE 11X5,5X1,5	SCHEIBE 11X5,5X1,5	ARANDELA 11X5,5X1,5
	6	800075160	5	RIVETTO	RIVET	RIVET	NIETE	REMACHE
	7	800069282	2	BOCCOLA 14X7X5,25 mm	BUSH 14X7X5.25 mm	DOUILLE 14X7X5,25 mm	BUCHSE 14X7X5,25 mm	CASQUILLO 14X7X5,25 mm
	8	800071621	1	BOCCOLA FORCELLONE 49,5 mm	COLLAR, SWINGARM 49.5 mm	DOUILLE, BRAS OSCILLANT 49,5 mm	BUCHSE, SCHWINGARM 49,5 mm	BUJE BASCULANTE 49,5 mm
	8	8A0071621	1	BOCCOLA FORCELLONE 58,5 mm	COLLAR, SWINGARM 58.5 mm	DOUILLE, BRAS OSCILLANT 58,5 mm	BUCHSE, SCHWINGARM 58,5 mm	BUJE BASCULANTE 58,5 mm
	9	8000H3012	1	DISTANZIALE 12X8,2X9	SPACER 12X8.2X9	ENTRETOISE 12X8,2X9	ABSTANDHALTER 12X8,2X9	DISTANCIADOR 12X8,2X9
	10	Z00020536	3	VITE TE AUTOFILETTANTE 4,8X13	SCREW SELF-TAPPING 4.8X13	VIS TARAUD 4,8X13	GEWINDESCHRAUBE 4,8X13	TORNILLO AUTOROSCANTE 4,8X13
	11	8000H1320	1	PATTINO SCORRICATENA FORCELLONE	BUFFER, CHAIN TOUCH DEFENSE	PATIN PROTECTEUR BRAS OSCILLANT	KETTENGLEITFUEHRUNG	PATIN DESLIZAMIENTO CADENA
	12	Z00067997	2	VITE TEF M5X0,8X12	SCREW TEF M5X0.8 CH8	VIS TEF M5X0,8 CH8	SCHRAUBE TEF M5X0,8 CH8	TORNILLO TEF M5X0,8 CH8
	13	FA00P00173	1	PERNO FORCELLONE	AXE REAR SWING ARM	AXE BRAS OSCILLANT	SCHWINGENACHSE	PERNO BASCULANTE
	14	Z00020536	2	VITE TE AUTOFILETTANTE 4,8X13	SCREW SELF-TAPPING 4.8X13	VIS TARAUD 4,8X13	GEWINDESCHRAUBE 4,8X13	TORNILLO AUTOROSCANTE 4,8X13
	15	8000B1166	1	GUIDA TUBO FRENO	CLAMP, BRAKE HOSE	GUIDE TUYAU FREIN	FUEHRUNG, BREMSSCHLAUCH	GUIA MANGUERA FRENO
	16	8AB073909	1	CARTER CATENA	GUARD, CHAIN	CARTER CHAINE	KETTENGAEUSE	CARTER CADENA
	17	800096941	1	TENDICATENA SINISTRO	ADJUSTER, CHAIN LH	TENDEUR CHAINE GAUCHE	KETTENSPELLER LINKS	TENSIONADOR CADENA IZQUERDO
	18	800096944	1	TENDICATENA DESTRO	ADJUSTER, CHAIN RH	TENDEUR CHAINE DROIT	KETTENSPELLER RECHTS	TENSIONADOR CADENA DERECHO
	19	Z00071623	1	DADO FLANGIATO M16X1,5	NUT FLANGE M16X1.5	ECROU BRIDE M16X1,5	GEFLANSCHTE MUTTER M16X1,5	TUERCA CON REBORDE M16X1,5
	20	ZC0061121	2	VITE TE M8X1,25	SCREW TE M8X1.25	VIS TE M8X1,25	SCHRAUBE TE M8X1,25	TORNILLO TE M8X1,25
	21	Z00017810	2	DADO M8X1,25	NUT M8X1.25	ECROU M8X1,25	MUTTER M8X1,25	TUERCA M8X1,25
	22	Z00008536	2	RONDELLA 13X8,4X2	WASHER 13X8.4X2	RONDELLE 13X8,4X2	SCHEIBE 13X8,4X2	ARANDELA 13X8,4X2
	23	ZA0067997	1	VITE TEF M5X0,8X16	SCREW TEF M5X0.8X16	VIS TEF M5X0,8X16	SCHRAUBE TEF M5X0,8X16	TORNILLO TEF M5X0,8X16
	24	8000H3033	3	SCODELLINO	CUP	COUPELLE	EINSTELLE	COPELA
	25	8000H2125	1	DISTANZIALE	SPACER	ENTRETOISE	ABSTANDHALTER	DISTANCIADOR
	26	8A0069282	2	DISTANZIALE 14X7X5,25 mm	SPACER 14X7X5.25 mm	ENTRETOISE 14X7X5,25 mm	ABSTANDHALTER 14X7X5,25 mm	DISTANCIADOR 14X7X5,25 mm
SM 500R	27	800072875	2	PIASTRINA	PLATE	PLAQUETTE	PLAETTCHEN	PLETINA
SM 500R	28	800072874	1	CRUNA CATENA	GUIDE, CHAIN	GUIDE CHAINE	KETTENFUEHRUNG	GUIA CADENA
SM 500R	29	Z00062731	2	VITE TEF M6X1X45	SCREW TEF M6X1X45	VIS TEF M6X1X45	SCHRAUBE TEF M6X1X45	TORNILLO TEF M6X1X45
	30	ZC0067997	1	VITE M5X20	SCREW M5X20	VIS M5X20	SCHRAUBE M5X20	TORNILLO M5X20
SM 500R	31	800065411	1	RULLO TENDICATENA	ROLLER, CHAIN TENSIONER	ROULEAU, TENDEUR CHAINE	ROLLE, KETTENSPELLER	RODILLO, TENSIONADOR CADENA
SM 500R	32	8A0036984	1	BOCCOLA	BUSHING	DOUILLE	BUCHSE	CASQUILLO

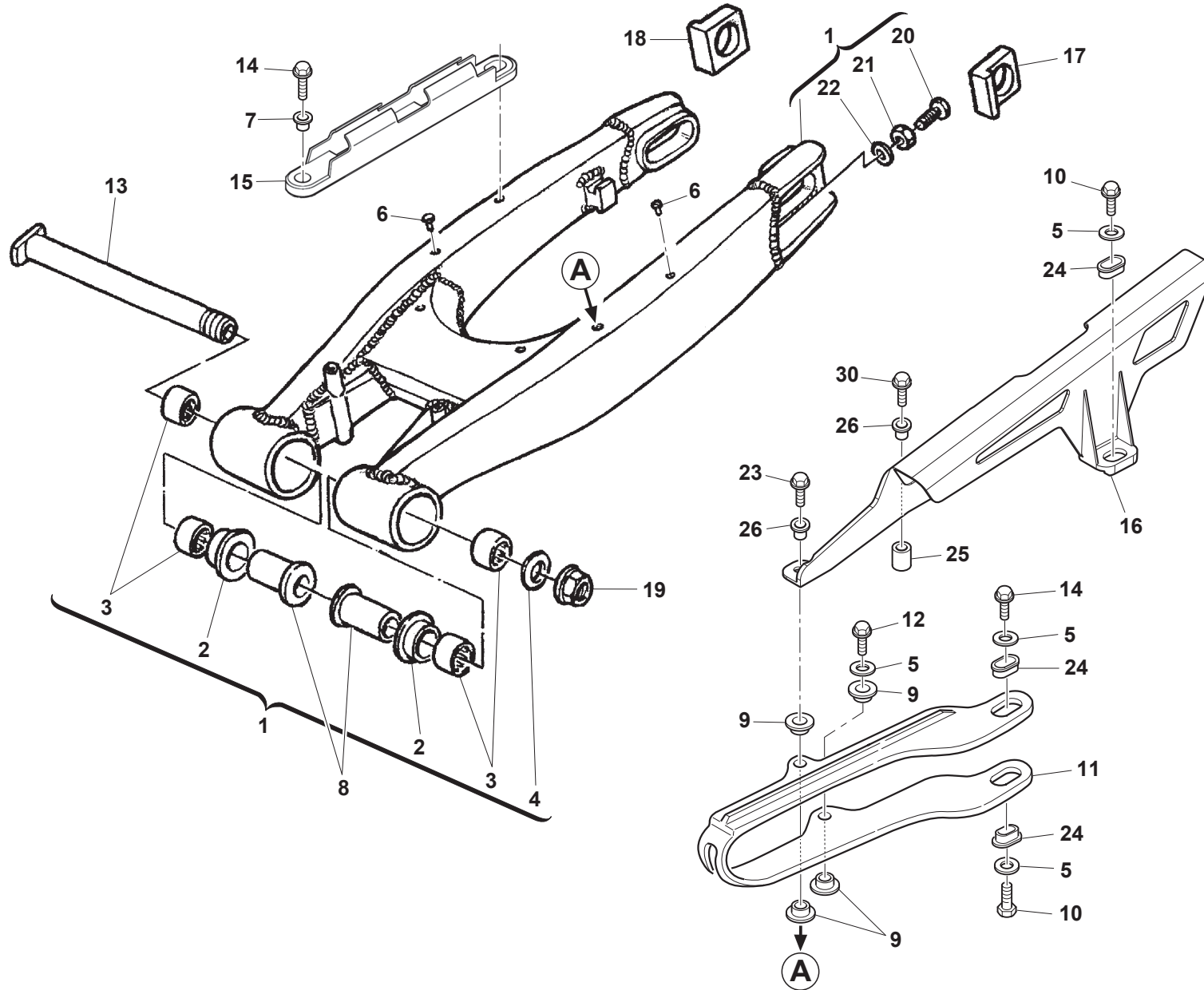

RS 300R - RS 500R

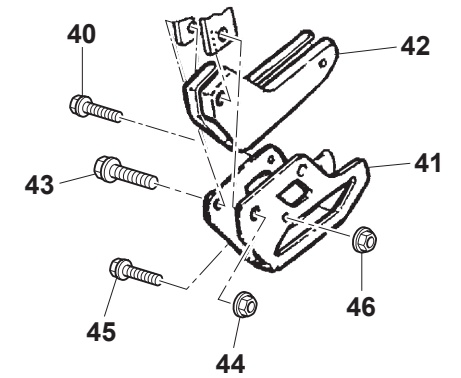

SM 500R

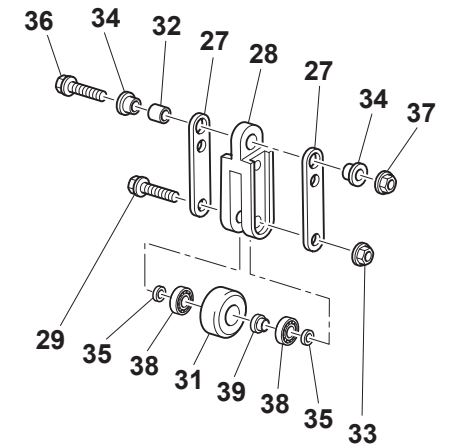

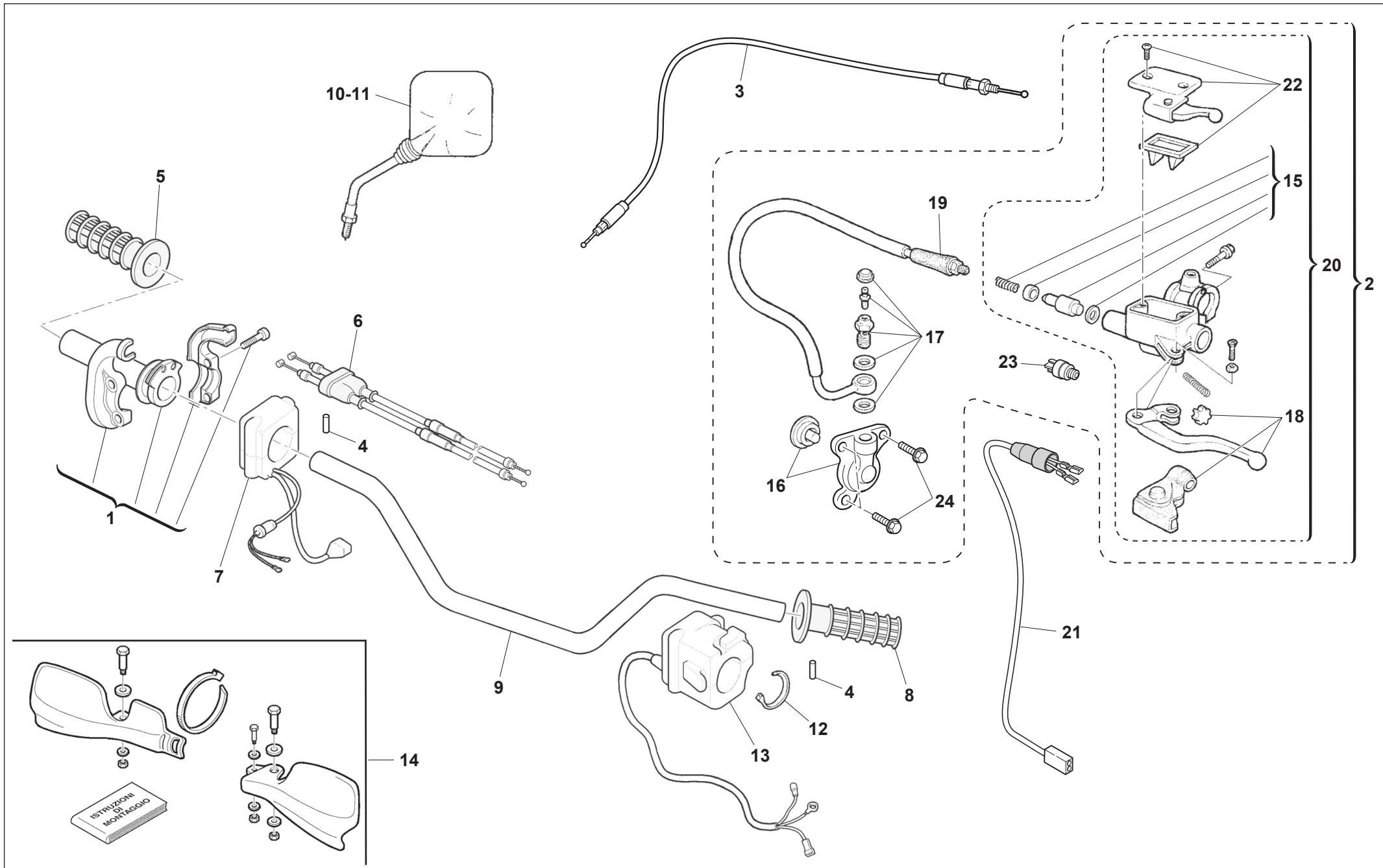



RS 300R/2016
RS 500R/2016
SM 500R/2016

MANUBRIO E COMANDI - HANDLEBAR AND CONTROLS
GUIDON ET COMMANDES - LENKER UND STEUERORGANE
MANILLAR Y MANDOS

TAVOLA
DRAWING
TABLE
BILD
TABLA

23

Note Notes Notes Marke Notas	Pos. No. Index Pos.	N. Cod. Code No. Nr. Code Code Nr N. Cod.	Q.tà Q.ty Q.te M.ge C.ad	DENOMINAZIONE	NAME	DESIGNATION	BESHREIBUNG	DENOMINACION
	1	800098209	1	COMANDO GAS	GRIP, THROTTLE	COMMANDE GAZ	GASSCHALTUNG	MANDO ACELERADOR
	2	FA00A00036	1	IMPIANTO COMANDO FRIZIONE	CLUTCH CONTROL SYSTEM	SYSTEME COMMANDE EMBRAYAGE	KUPPLUNGSHEBELSCHALTUNGANLAGE	SISTEMA MANDO EMBRAGUE
	3	8000A7777	1	CAVO STARTER	CABLE, STARTER	CABLE COMMANDE STARTER	STARTERKABEL	CABLE STARTER
	4	8000A1074	2	PIOLO	HOB	BARREAU	PFLOCK	CLAVIJA
	5	800076688	1	MANOPOLA DESTRA	HAND GRIP RH	POIGNEE DROIT	HANDGRIFF RECHTS	PUNO DERECHO
	6	8000B1927	1	CAVO GAS	CABLE, THROTTLE	CABLE GAZ	GASSEIL	CABLE ACELERADOR
	7	8000H1174	1	COMMUTATORE LUCI DESTRO	HANDLE SWITCH, RH	COMMUTATEUR FEUX DROITE	RECHTER LICHTSCHALTER	CONMUTADOR LUCES DERECHO
	8	800076687	1	MANOPOLA SINISTRA	HAND GRIP LH	POIGNEE GAUCHE	HANDGRIFF LINKS	PUNO IZQUERDO
	9	8000H6609	1	MANUBRIO	HANDLEBAR	GUIDON	LENKER	MANILLAR
	10	8A00H1673	1	SPECCHIO DESTRO	MIRROR, RH	MIROIR DROIT	SPIEGEL RECHTS	ESPEJO DERECHO
	11	8000H1673	1	SPECCHIO SINISTRO	MIRROR, LEFT	MIROIR GAUCHE	SPIEGEL LINKS	ESPEJO IZQUERDO
	12	800071578	1	FASCETTA	CLAMP	COLLIER	SHELLE	ABRAZADERA
	13	8000H1173	1	COMMUTATORE LUCI SINISTRO	HANDLE SWITCH, LEFT	COMMUTATEUR FEUX GAUCHE	LINKER LENKERSCHALTER	CONMUTADOR LUCES IZQUERDO
	14	8000H5050	1	KIT PARAMANI	HAND GUARD KIT	KIT DE PROTECTION MAINS	HANDSCHUT-KIT	KIT PROTECTOR MANOS
	15	F000A00797	1	KIT PISTONCINO POMPA FRIZIONE	CYLINDER KIT, MASTER	KIT PISTON POMPE	KOLBEN, PUMPE KIT	KITPISTON BOMBA
	16	F000A00798	1	SPINGIFRIZIONE IDRAULICO	CYLINDER, CLUTCH PRESSURE	CYLINDRE POUSSEE EMBRAYAGE	KUPPLUNGSZYLINDERDRUCH	CILINDRO EMPUJADOR EMBRAGUE
	17	F000A00799	1	VITE SPURGO	SCREW, BLEED	VIS VIDANGE	SCHRAUBE, ABLASS	TORNILLO PURGA
	18	F000A00800	1	KIT LEVA FRIZIONE	CLUTCH LEVER KIT	KIT LEVIER EMBRAYAGE	KUPPLUNGSHEBEL KIT	KIT PALANCA EMBRAGUE
	19	8000A2841	1	TUBO OLIO FRIZIONE	HOSE, CLUTCH OIL	TUYAU HUILE EMBRAYAGE	KUPPLUNGSSTEUERUNGSSCHLAUCH	TUBO MANDO EMBRAGUE
	20	F000A00802	1	POMPA FRIZIONE	CLUTCH MASTER CYLINDER	MAITRE-CYLINDRE EMBRAYAGE	KUPPLUNGSHAUPTZYLINDER	BOMBA EMBRAGUE
	21	800075477	1	CAVO MICROINTERRUTTORE	MICROSWITCH CABLE	CABLAGE MICROINTERRUPTEUR	VERKABELUNG MIKROSCHALTER	CABLEADO MICROINTERRUPTOR
	22	F000A00805	1	KIT COPERCHIO POMPA FRIZIONE	CLUTCH PUMP COVER KIT	KIT COUVERCLE MAITRE-CYLINDRE	DECKEL PUMPE KIT	KIT TAPA BOMBA
	23	F000P00804	1	MICROINTERRUTTORE	MICROSWITCH	MICROINTERRUPTEUR	MIKROSCHALTER	MICROINTERRUPTOR
	24	Z00062727	3	VITE TEF M6X1X16	SCREW TEF M6X1X16	VIS TEF M6X1X16	SCHRAUBE TEF M6X1X16	TORNILLO TEF M6X1X16

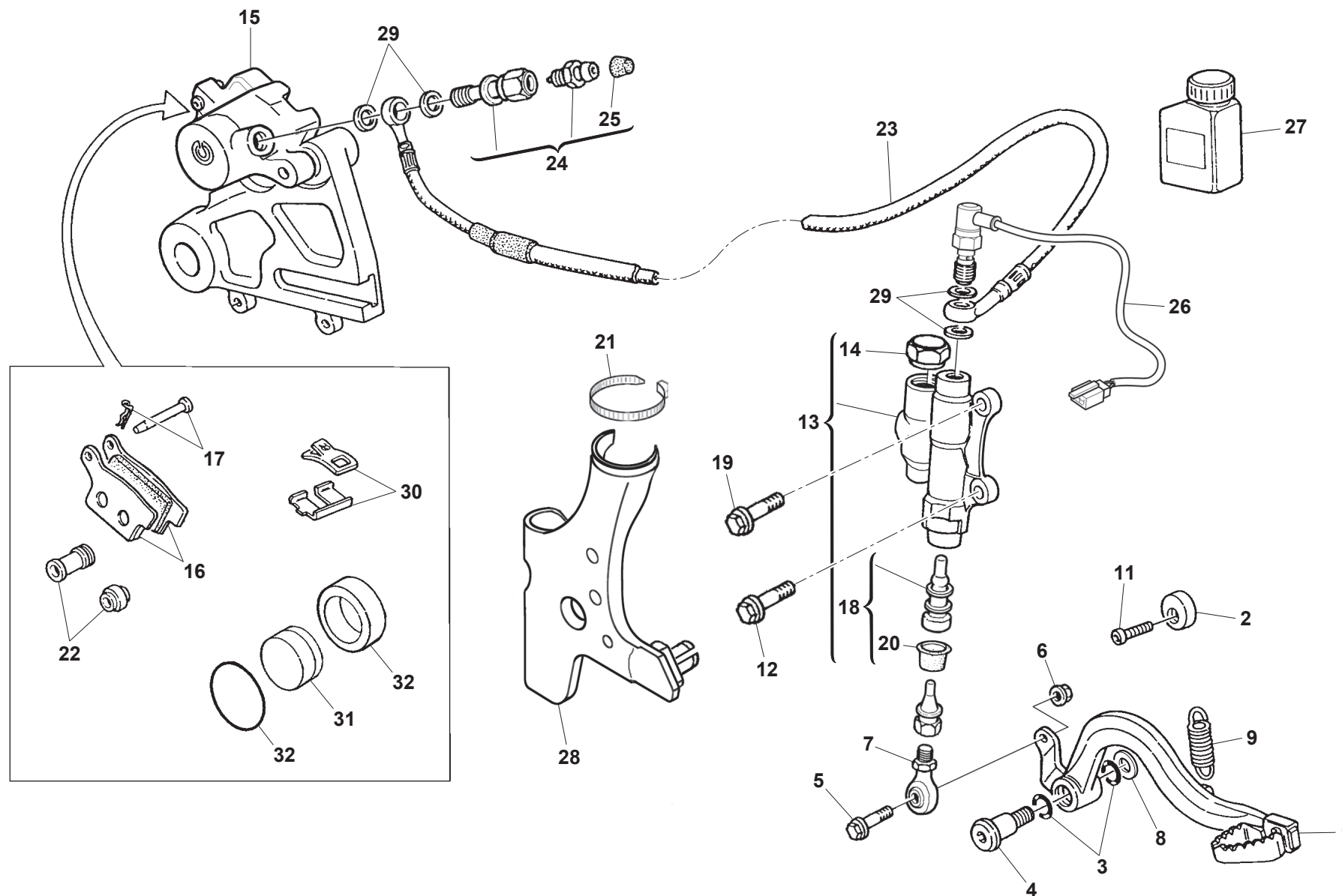



RS 300R/2016
RS 500R/2016
SM 500R/2016

FRENO IDRAULICO POSTERIORE - REAR HYDRAULIC BRAKE
FREIN HYDRAULIQUE ARRIERE - HINTERBREMSE
FRENO HIDRAULICO TRASERO

TAVOLA
DRAWING
TABLE
BILD
TABLA

24

Note Notes Notas	Pos. No. Index Pos.	N. Cod. Code No. Nr. Code Code Nr N. Cod.	Q.tà Q.ty Q.te M.ge C.ad	DENOMINAZIONE	NAME	DESIGNATION	BESHREIBUNG	DENOMINACION
	1	8000A7634	1	PEDALE FRENO	PEDAL, BRAKE	PEDALE FREIN	FUSSBREMSPEDAL	PEDAL FRENO
	2	8A0069125	1	ECCENTRICO PEDALE FRENO	ECCENTRIC, ADJUSTMENT BRAKE PEDAL	EXCENTRIQUE REGLAGE PEDAL FREIN	REGULIEREXZENTIKER BREMSE PEDAL	EXCENTRICO REGULACION PEDAL FRENO
	3	800022551	2	ANELLO O-RING 2056 14X1,78	O-RING 2056 14X1.78	JOINT TORIQUE 2056 14X1,78	O-RING 2056 14X1,78	JUNTA TORICA 2056 14X1,78
	4	Y00055902	1	VITE TPEI M10X1,25X16	SCREW TPEI M10X1.25X16	VIS TPEI M10X1,25X16	SCHRAUBE TPEI M10X1,25X16	TORNILLO TPEI M10X1,25X16
	5	Z00062727	1	VITE TE M6X1X16 CH8	SCREW TE M6X1X16 CH8	VIS TE M6X1X16 CH8	SCHRAUBE TE M6X1X16 CH8	TORNILLO TE M6X1X16 CH8
	6	61ND15062	1	DADO M6X1 H4 CH10	NUT M6X1 H4 CH10	ECROU M6X1 H4 CH10	MUTTER M6X1 H4 CH10	TUERCA M6X1 H4 CH10
	7	8A0076055	1	SNODO SFERICO DESTRO	BALL JOINT, RH	JOINT A ROTULE, DROIT	KUGELGELENK, RECHTS	ROTULA ESFERICA DERECHA
	8	8000H1412	1	ROSETTA 10,5X25X2	WASHER 10,5X25X2	RONDELLE 10,5X25X2	UNTERLEGSCHLEIBE 10,5X25X2	ARANDELA 10,5X25X2
	9	8A0055903	1	MOLLA PEDALE FRENO	SPRING, BRAKE PEDAL	RESSORT PEDALE FREIN	FEDER, BREMSPEDAL	MUELLE PEDAL FRENO
	10	8000A7635	1	PUNTALINO POMPA FRENO	ROD-PUSH, MASTER CYLINDER	BARRE PRESSION	DRUCKSTANGE	VARILLA PRESION
	11	Y00055241	1	VITE TSEI M6X1X14 CH5	SCREW TSEI M6X1X14 CH5	VIS TSEI M6X1X14 CH5	SCHRAUBE TSEI M6X1X14 CH5	TORNILLO TSEI M6X1X14 CH5
	12	Z00062726	1	VITE TEF M6X1,00X14 CH8	SCREW TEF M6X1.00X14 CH8	VIS TEF M6X1,00X14 CH8	SCHRAUBE TEF M6X1,00X14 CH8	TORNILLO TEF M6X1,00X14 CH8
	13	8000A7633	1	POMPA FRENO POSTERIORE	CYLINDER, REAR MASTER	MAITRE CYLINDRE FREIN ARRIERE	HAUPTZYLINDER, HINTEN	BOMBA FRENO TRASERO
	14	8000A9447	1	TAPPO POMPA FRENO POSTERIORE	PLUG CYLINDER, REAR MASTER	BOUCHON MAITRE CYLINDRE FREIN ARRIERE	VERSCHLUSS HAUPTZYLINDER, HINTEN	TAPON BOMBA FRENO TRASERO
	15	8000A4291	1	PINZA FRENO POSTERIORE	CALIPER, REAR BRAKE	ETRIER FREIN ARRIERE	HINTEN BREMSSELTEL	PINZA FRENO TRASERA
	16	8000A2790	1	COPIA PASTIGLIE FRENO POSTERIORE	PADS SET, REAR BRAKE	JEU PLAQUETTES FREIN ARRIERE	HINTERBREMSBELAEGESATZ	JUEGO PASTILLAS FRENO TRASERO
	17	8000A2791	1	GRUPPO REVISIONE PERNI PASTIGLIE	PAD PINS OVERHAUL SET	GROUPE REVISION PIVOTS PLAQUETTE	BREMSBELAEGEN EBERHOLUNGSGRUPPE	GRUPO REVISION PERNO PASTILLAS FRENO
	18	8000A9448	1	ASTINA POMPA FRENO	ROD, BRAKE CYLINDER	TIGE MAITRE CYLINDRE	HAUPTZYLINDERSTANGE	VARILLA BOMBA FRENO
	19	8B00A8423	1	VITE M6X1X16	SCREW M6X1X16	VIS M6X1X16	SCHRAUBE M6X1X16	TORNILLO M6X1X16
	20	8000A9449	1	CUFFIA	BOOT	COIFFE	HAUBE	GORRO
	21	800056444	1	FASCETTA 188 mm	CLAMP 188 mm	COLLIER 188 mm	SCHELLE 188 mm	ABRAZADERA 188 mm
	22	800079066	1	SERIE SILENTBLOCK PINZA FRENO	CAPS OVERHAUL SET	GROUPE REVISION CAPOUCHONS	GUMMIUBERARBITUNGSAZ	GRUPO REVISION GORRO
	23	8A00B1162	1	TUBO FRENO POSTERIORE	HOSE, REAR BRAKE	TUYAU FREIN ARRIERE	BREMSSCHLAUCH HINTEN	MANGUERA FRENO TRASERO
	24	8000A3975	1	VITE RACCORDO TUBO OLIO	BOLT, OIL PIPE	VIS FIXATION TUYAU HUILE	FIXIERSCHRAUBE OELSCHLAUCH	TORNILLO FIJACION TUBO ACEITE
	25	800053259	1	CAPPUCCIO VITE SPURGO	CAP, BLEEDER SCREW	CAPUCHON VIS RENIFLARD	ENTLUEFTUNGSKAPPE	CAPUCHON TORNILLO PURGA PINZA
	26	800094849	1	INTERRUTTORE STOP POSTERIORE	SWITCH, REAR BRAKE	INTERRUPTEUR STOP ARRIERE	HINTEN STOPSCHALTER	INTERRUPTOR STOP TRASERO
	27	A000P00720	1	LIQUIDO FRENI	BRAKE FLUID	LIQUIDE FREIN	BREMSFLUESSIGKEIT	LIQUIDO FRENO
	28	8000H3434	1	PROTEZIONE POMPA FRENO POSTERIORE	COVER, REAR MASTER CYLINDER	PROTECTION MAITRE CYLINDRE ARRIERE	HINTERBREMSEPUMPESCHUTZ	PROTECCION BOMBA FRENO TRASERO
	29	800021480	4	RONDELLA 14X10,2X1,5	WASHER 14X10.2X1.5	RONDELLE 14X10,2X1,5	SCHLEIBE 14X10,2X1,5	ARANDELA 14X10,2X1,5
	30	8000A2792	1	MOLLETTE PASTIGLIE FRENO	SUPPORT, PAD	RESSORT PLAQUETTE FREIN	FEDER, BREMSSEHEIBE	MUELLE PASTILLAS
	31	8000A2793	1	PISTONCINO PINZA FRENO	PISTON, CALIPER	PISTON ETRIER FREIN	KOLBEN BREMSSELTEL	PISTON PINZA FRENO
	32	8000A2794	1	SERIE GUARNIZIONI PISTONCINO PINZA	KIT GASKET PISTON	KIT GARNITURE PISTON	KIT KOLBENDICHTUNG	KIT JUNTAS PISTON

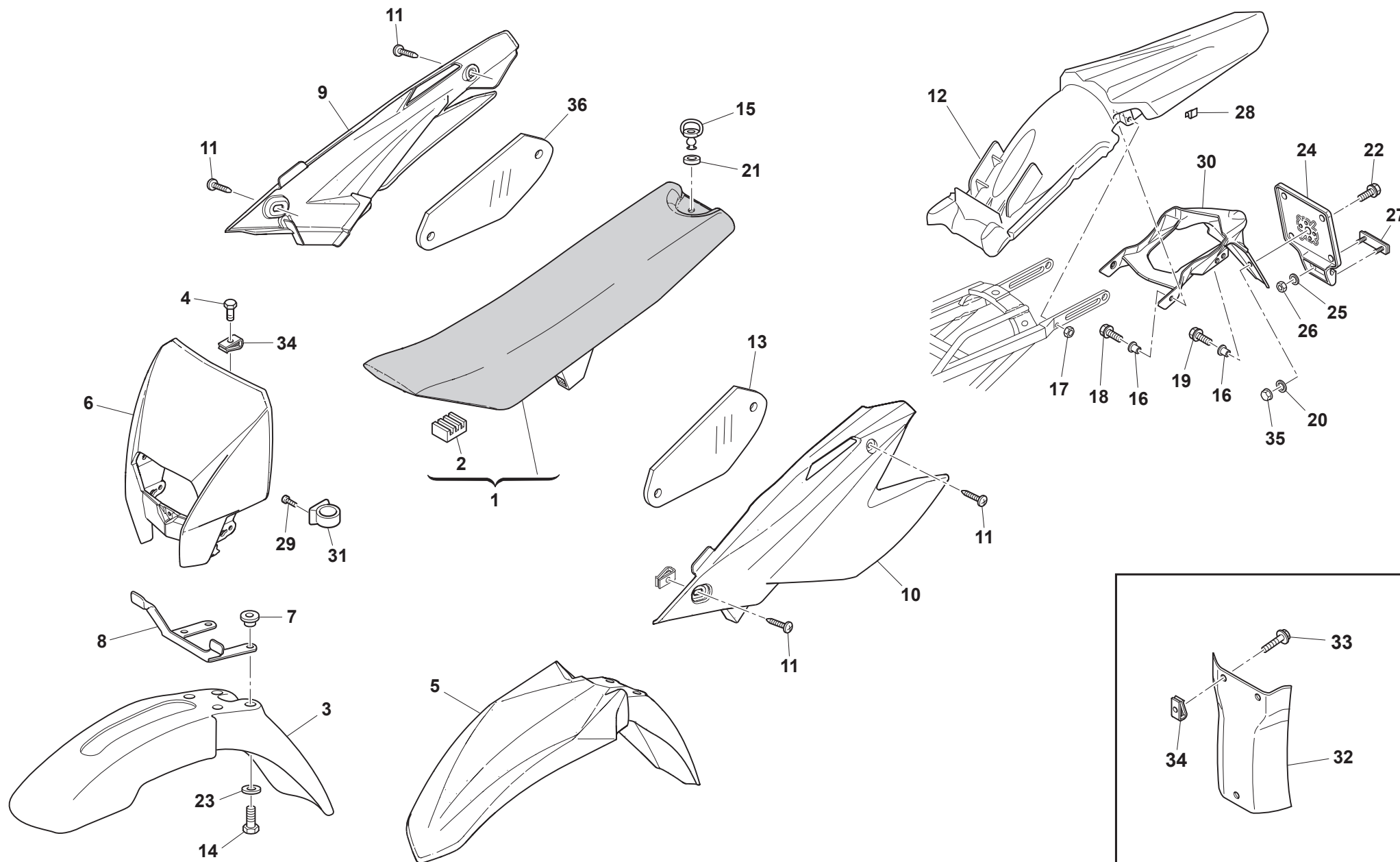



RS 300R/2016
RS 500R/2016
SM 500R/2016

PANNELLI, PARAFANGHI, SELLA, PORTATARGA - PANEL, FENDERS, SEAT, PLATE HOLDER
PANNEAU, GARDE-BOUES, SIEGE, PORTE-BALAI - STREIFEN, KOTFLUGEL, SATTEL, SCHILDTRÄGER
PANELO, GUARDABARROS, SILLIN, PORTAMATRICULA

TAVOLA
DRAWING
TABLE
BILD
TABLA

25

Note Notes Notes Marke Notas	Pos. No. N. Index Pos.	N. Cod. Code No. Nr. Code Code Nr N. Cod.	Q.tà Q.ty Q.te M.ge C.ad	DENOMINAZIONE	NAME	DESIGNATION	BESHREIBUNG	DENOMINACION
	1	F000A00114	1	SELLA	SADDLE	SELLE	SITZBANK	ASIENTO
	2	86610191A	2	TAMPONE IN GOMMA	CUSHION RUBBER	TAMPON EN CAOUTCHOUC	GUMMISTOPFEN	TAMPON GOMA
SM 500R	3	8AC0H0525	1	PARAFANGO ANTERIORE	FENDER, FRONT	GARDE BOUE AVANT	KOTFLUEGEL VORNE	GUARDABARROS DELANTERO
	4	8A00A8421	1	VITE FLANGIATA M5X12	BOLT, FLANGE M5X12	VIS A EMBASE M5X12	GEFLANSCHSCHRAUBE M5X12	TORNILLO CON VALONA M5X12
RS 300-RS 500R	5	F000P00156	1	PARAFANGO ANTERIORE	FRONT MUDGUARD	GARDE-BOUE AVANT	VORDERRADKOTFLÜGEL	GUARDABARROS DELANTERO
	6	F000A00227	1	CUPOLINO	FRONT FAIRING	NEZ DE CARÉNAGE	WINDSCHUTZSCHEIBE	CÚPULA
	7	ZC0069429	4	BOCCOLA 9X7X9,5 mm	BUSH 9X7X4.8 mm	DOUILLE 9X7X4,8 mm	BUCHSE 9X7X4,8 mm	BUJE 9X7X4,8 mm
	8	8000A6644	1	SUPPORTO CUPOLINO	BRACKET, COWLING	SUPPORT CAPOT	KONSOLE, KOPFVERKLEIDUNG	SOPORTE CUPULA
	9	F000P00141	1	FIANCHETTO DESTRO	COVER, FRAME RH	COUVERCLE CADRE DROIT	SEITENDECKEL, RECHTS	CUBIERTA BASTIDOR DERECHA
	10	F000P00140	1	FIANCHETTO SINISTRO	COVER, FRAME LH	COUVERCLE CADRE GAUCHE	SEITENDECKEL, LINKS	CUBIERTA BASTIDOR IZQUERDA
SM 500R	11	8B00A8421	4	VITE FLANGIATA M5X16	SCREW M5X14	VIS M5X16	SCHRAUBE M5X16	TORNILLO M5X16
	12	8000H1705	1	PARAFANGO POSTERIORE	FENDER, REAR	GARDE-BOUE ARRIERE	KOTFLUEGEL HINTEN	GUARDABARROS TRASERO
RS 300R - RS 500R	12	F000P00228	1	PARAFANGO POSTERIORE	REAR MUDGUARD	GARDE-BOUE ARRIÈRE	HINTERRADKOTFLÜGEL	GUARDABARROS TRASERO
	13	F000P00241	1	ISOLANTE TERMICO SINISTRO	GUARD, HEAT L.H.	ISOLATEUR THERMIQUE GAUCHE	WAERMISOLIERSTOFF LINKS	AISILANTE ATERMICO IZQUERDO
	14	Z00062729	4	VITE TEF M6X1X25 CH8	SCREW TEF M6X1X25 CH8	VIS TEF M6X1X25 CH8	SCHRAUBE TEF M6X1X25 CH8	TORNILLO TEF M6X1X25 CH8
	15	8000H1917	1	PERNO ATTACCO SELLA	PIN, SADDLE	AXE SELLE	SITZACHSE	PERNO ASIENTO
	16	Z00069429	2	BOCCOLA 9X7X4,8 mm	BUSH 9X7X4.8 mm	DOUILLE 9X7X4,8 mm	BUCHSE 9X7X4,8 mm	BUJE 9X7X4,8 mm
	17	Z00044240	2	DADO AUTOBLOCCANTE M6X1 CH10	NUT, SELF LOCKING M6X1 CH10	ECROU AUTOBLOQUANT M6X1 CH10	SELBSTSPERRENDE MUTTER M6X1 CH10	TUERCA AUTOBLOQUEANTE M6X1 CH10
	18	ZPA067545	2	VITE TEF M6X1X22 CH8	SCREW TEF M6X1X22 CH8	VIS TEF M6X1X22 CH8	SCHRAUBE TEF M6X1X22 CH8	TORNILLO TEF M6X1X22 CH8
	19	Z00062728	2	VITE TE M6X1X20	SCREW TE M6X1X20	VIS TE M6X1X20	SCHRAUBE TE M6X1X20	TORNILLO TE M6X1X20
	20	62ND15547	2	RONDELLA 15X5,3X1	WASHER 15X5.3X1	RONDELLE 15X5,3X1	SCHEIBE 15X5,3X1	ARANDELA 15X5,3X1
	21	800069149	1	RONDELLA 17X9X1	WASHER 17X9X1	RONDELLE 17X9X1	SCHEIBE 17X9X1	ARANDELA 17X9X1
	22	Z00062727	2	VITE TEF M6X1X16	SCREW TEF M6X1X16	VIS TEF M6X1X16	SCHRAUBE TEF M6X1X16	TORNILLO TEF M6X1X16
	23	Z00048814	4	RONDELLA 18X6,4X2	WASHER 18X6.4X2	RONDELLE 18X6,4X2	SCHEIBE 18X6,4X2	ARANDELA 18X6,4X2
	24	8000H3018	1	PIASTRA PORTATARGA	BRACKET, LICENSE PLATE	PORTE-PLAQUE IMMATRICULATION	KONSOLE, KENNZEICHEN	PORTA-MATRICULA
	25	62ND15547	2	RONDELLA 12X4,3X0,8	WASHER 12X4.3X0.8	RONDELLE 12X4,3X0,8	SCHEIBE 12X4,3X0,8	ARANDELA 12X4,3X0,8
	26	Z00040717	2	DADO AUTOBLOCCANTE M4X0,7	NUT, SELF LOCKING M4X0.7	ECROU AUTOBLOQUANT M4X0,7	SELBSTSPERRENDE MUTTER M4X0,7	TUERCA AUTOBLOQUEANTE M4X0,7
	27	800073834	1	CATADIOTTRO POSTERIORE	REFLEX REFLECTOR, REAR	CATADIOPTE ARRIERE	RUECKSTRAHLER	CATAFARO TRASERO
	28	800072494	1	MOLLETTA FERMACAVO	CLAMP, WIRE	COLLIER, CORDON	KABELBINDER	GRAMPA CORDON
	29	ZA0037283	2	VITE AUTOFILETTANTE AB 3,5X13	SCREW SELF-TAPPING AB 3.5X13	VIS TARAUD AB 3,5X13	GEWINDESCHRAUBE AB 3,5X13	TORNILLO AUTOROSCANTE AB 3,5X13
	30	8000H1405	1	PARAFANGO POSTERIORE PORTATARGA	FENDER, REAR NUMBER PLATE HOLDER	GARDE-BOUE ARRIERE PORTE-PLAQUE	KOTFLUEGEL HINTEN KENNZEICHEN	GUARDABARROS TRASERO PORTA-MATRICULA
	31	8000A0864	1	GUIDA TUBO FRENO ANTERIORE	GUIDE, FRONT BRAKE HOSE	GUIDE TUYAU FREIN AVANT	BREMSSCHLAUCH VORNEFUEHRUNG	GUIA MANGUERA FRENO DELANTERO
	32	800069551	1	PROTEZIONE AMMORTIZZATORE POSTERIORE	COVER, SHOCK ABSORBER	PROTECTION AMORTISSEUR	SCHUTZ, FEDERBEIN	PROTECCION AMORTIGUADOR TRASERO

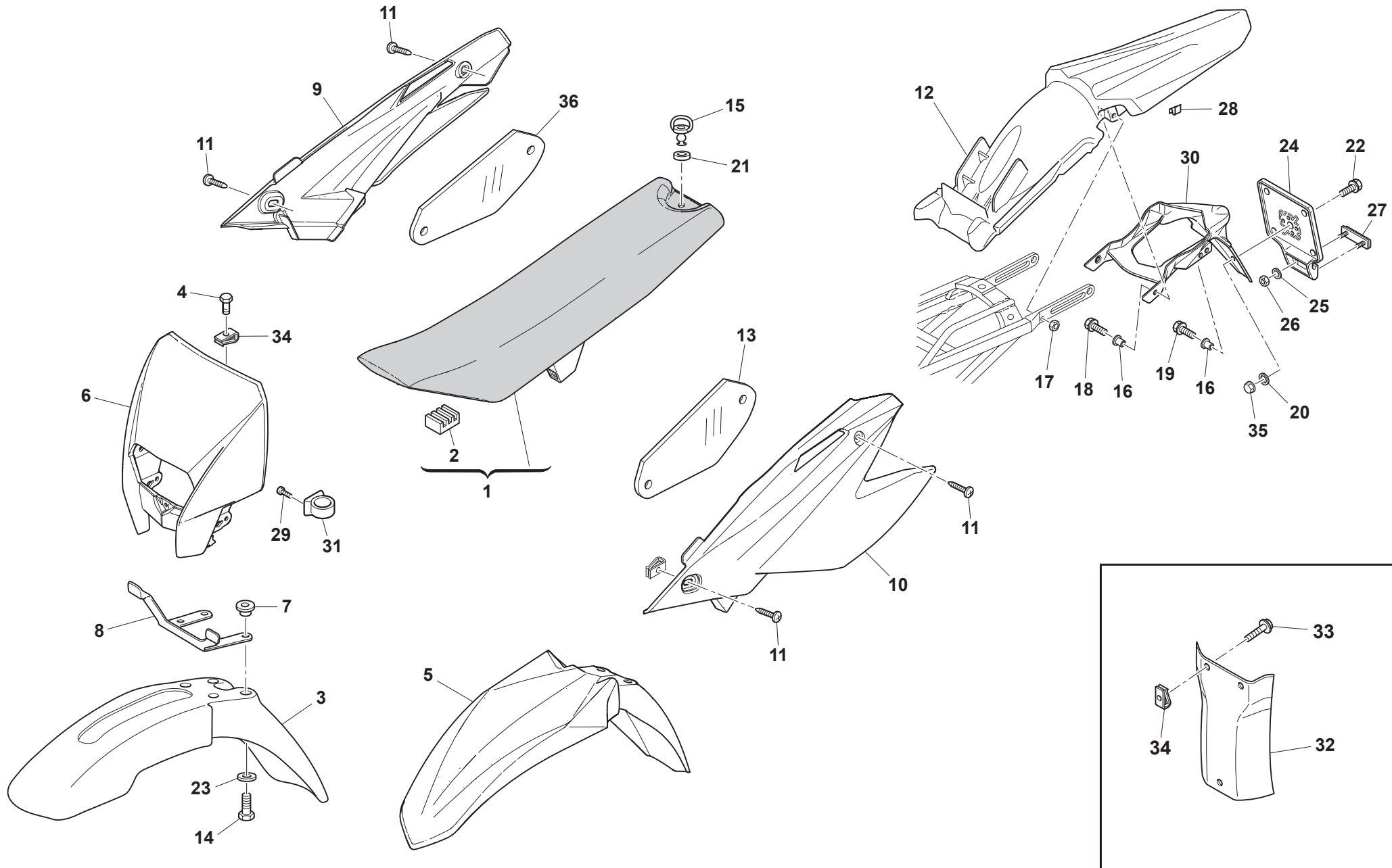

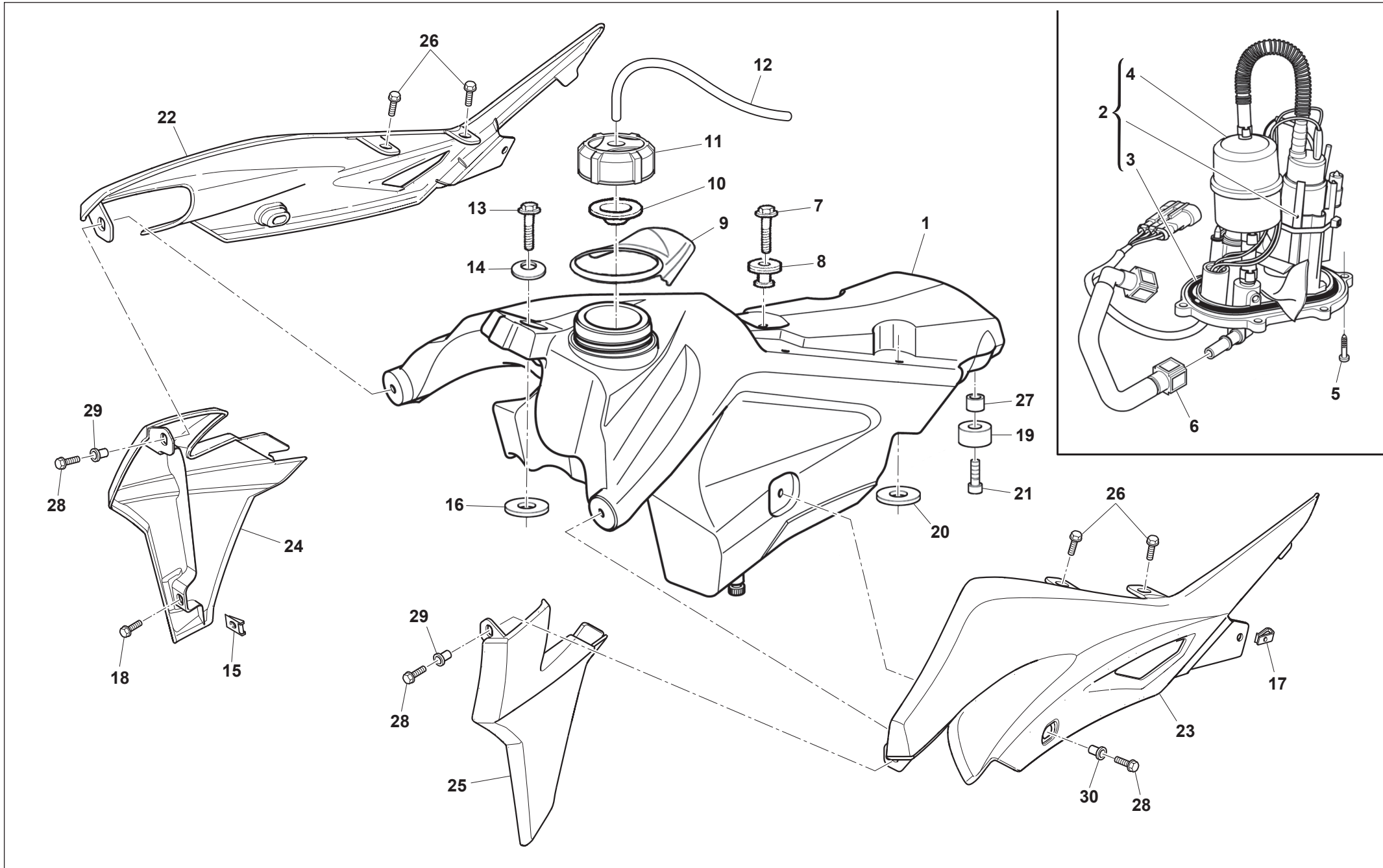



RS 300R/2016
RS 500R/2016
SM 500R/2016

SERBATOIO CARBURANTE, CONVOGLIATORI - GAS TANK, PANEL
RESERVOIR CARBURANT, FLANC - KRAFTSTOFFBEHALTER, FLANKE
DEPOSITO GASOLINA, LATERAL

TAVOLA
DRAWING
TABLE
BILD
TABLA

26

Note Notes Notes Marke Notas	Pos. No. N. Index Pos.	N. Cod. Code No. Nr. Code Code Nr N. Cod.	Q.tà Q.ty Q.te M.ge C.ad	DENOMINAZIONE	NAME	DESIGNATION	BESHREIBUNG	DENOMINACION
	1	80A0B0249	1	SERBATOIO CARBURANTE	FUEL TANK	RESERVOIR CARBURANT	KRAFTSTOFFTANK	DEPOSITO CARBURANTE
	2	8000H2930	1	POMPA CARBURANTE	PUMP, FUEL	POMPE CARBURANT	KRAFTSTOFFPUMPE	BOMBA CARBURANTE
	3	8000H0184	1	GUARNIZIONE	GASKET	JOINT	DICHTUNG	JUNTA
	4	8000H0183	1	FILTRO CARBURANTE	FILTER, FUEL	FILTRE CARBURANT	KRAFTSTOFFFILTER	FILTRO CARBURANTE
	5	ZA0067997	6	VITE TEF M5X0,8X16	SCREW TEF M5X0.8X16	VIS TEF M5X0,8X16	SCHRAUBE TEF M5X0,8X16	TORNILLO TEF M5X0,8X16
	6	8000B0250	1	TUBO CARBURANTE ALTA PRESSIONE	HOSE, FUEL HIGH PRESSURE	TUYAU CARBURANT HAUTE PRESSION	KRAFTSTOFFSCHLAUCH HOCHDRUCK	MANGUERA CARBURANTE ALTA PRESION
	7	60ND04134	1	VITE TSCI M6X1X20	SCREW TSCI M6X1X20	VIS TSCI M6X1X20	SCHRAUBE TSCI M6X1X20	TORNILLO TSCI M6X1X20
	8	800066238	1	DISTANZIALE 20X10X6,5X12 mm	SPACER 20X10X6.5X12 mm	ENTRETOISE 20X10X6,5X12 mm	ABSTANDHALTER 20X10X6,5X12 mm	DISTANCIADOR 20X10X6,5X12 mm
	9	8000B1390	1	PROTEZIONE TAPPO	PLUG GUARD	PROTECTION	SCHUTZ	PROTECCION
	10	8000A4562	1	GUARNIZIONE TAPPO SERBATOIO	GASKET, CAP	JOINT, BOUCHON RESERVOIR	DICHTUNG, VERSCHLUSSKAPPE	JUNTA TAPON DEPOSITO
	11	8000B1057	1	TAPPO SERBATOIO CARBURANTE	CAP SET, FUEL TANK	BOUCHON RESERVOIR CARBURANT	VERSCHLUSS, KRAFTSTOFFTANK	TAPON DEPOSITO CARBURANTE
	12	8T0068873	1	TUBO CARBURANTE 300 mm	HOSE, FUEL 300 mm	TUYAU CARBURANT 300 mm	KRAFTSTOFFSCHLAUCH 300 mm	MANGUERA CARBURANTE 300 mm
	13	60ND07335	1	VITE TCEI M6X1,00X16	SCREW TCEI M6X1.00X16	VIS TCEI M6X1,00X16	SCHRAUBE TCEI M6X1,00X16	TORNILLO TCEI M6X1,00X16
	14	8000A5678	1	RONDELLA PIANA	WASHER, PLAIN	RONDELLE, PLATE	UNTERLEGSCHLEIBE	ARANDELA PLANA
	15	U00046893	4	DADO ELASTICO M5	CLIP NUT M6X1	ECROU D' AGRAFE M6X1	FEDERMUTTER M6X1	TUERCA DE CLIP M6X1
	16	800061362	1	RONDELLA 27X12X5 mm	WASHER 27X12X5 mm	RONDELLE 27X12X5 mm	SCHEIBE 27X12X5 mm	ARANDELA 27X12X5 mm
	17	U00055134	2	DADO ELASTICO M5X0,8	NUT M5X0.8	ECROU M5X0,8	MUTTER M5X0,8	TUERCA M5X0,8
	18	8A00A8421	4	VITE FLANGIATA M5X12	BOLT, FLANGE M5X12	VIS A EMBASE M5X12	GEFLANSCHSCHRAUBE M5X12	TORNILLO CON VALONA M5X12
	19	8000B0647	2	TAMPONE SERBATOIO	CUSHION, FUEL TANK	TAMPON APPUI RESERVOIR	DAEMPFER TANKAUFLAGE	TAMPON APOYO DEPOSITO
	20	8A0061362	1	RONDELLA IN GOMMA	WASHER, RUBBER	RONDELLE EN CAOUTCHOUC	GUMMISCHEIBE	ARANDELA GOMA
	21	Z00037745	2	VITE TCIC AUTOFILETTANTE 5,5X19	SCREW SELF-TAPPING TC1C 5.5X19	VIS TARAUD TC1C 5,5X19	GEWINDESCHRAUBE TC1C 5,5X19	TORNILLO AUTOROSCANTE TC1C 5,5X19
	22	F000P00159	1	CONVOGLIATORE DESTRO	COVER, RADIATOR, RH	OUIE RADIATEUR DROIT	RECHTES LEITBLECH	PROTECTOR RADIADOR DERECHO
	23	F000P00158	1	CONVOGLIATORE SINISTRO	COVER, RADIATOR, LH	OUIE RADIATEUR GAUCHE	LINKES LEITBLECH	DEFLECTOR AIRE IZQUERDO
	24	F000P00119	1	PROTEZIONE RADIATORE DESTRA	COVER RADIATOR RH	PROTECTION RADIATEUR DROIT	KUEHLERSCHUTZ, RECHTS	PROTECCION RADIADOR DERECHO
	25	F000P00118	1	PROTEZIONE RADIATORE SINISTRA	COVER RADIATOR LH	PROTECTION RADIATEUR GAUCHE	KUEHLERSCHUTZ, LINKS	PROTECCION RADIADOR IZQUERDO
	26	8000A8421	8	VITE FLANGIATA M5X8	BOLT, FLANGE M5X8	VIS A EMBASE M5X8	FLANSCHENSCHRAUBE M5X8	TORNILLO CON VALONA M5X8
	27	8B00A0680	2	DISTANZIALE 10,5X6,5X5 mm	SPACER 10.5X6.5X5 mm	ENTRETOISE 10,5X6,5X5 mm	ABSTANDHALTER 10,5X6,5X5 mm	DISTANCIADOR 10,5X6,5X5 mm
	28	ZA0067997	4	VITE TEF M5X0,8X16	SCREW TEF M5X0.8X16	VIS TEF M5X0,8X16	SCHRAUBE TEF M5X0,8X16	TORNILLO TEF M5X0,8X16
	29	ZA0069429	2	BUSSOLA D9-D7-SP8	BUSHING D9-D7-SP8	DOUILLE D9-D7-SP8	BUCHSE D9-D7-SP8	CASQUILLO D9-D7-SP8
	30	ZC0069429	2	BUSSOLA D9-D7-SP9,5	BUSHING D9-D7-SP9.5	DOUILLE D9-D7-SP9,5	BUCHSE D9-D7-SP9,5	CASQUILLO D9-D7-SP9,5

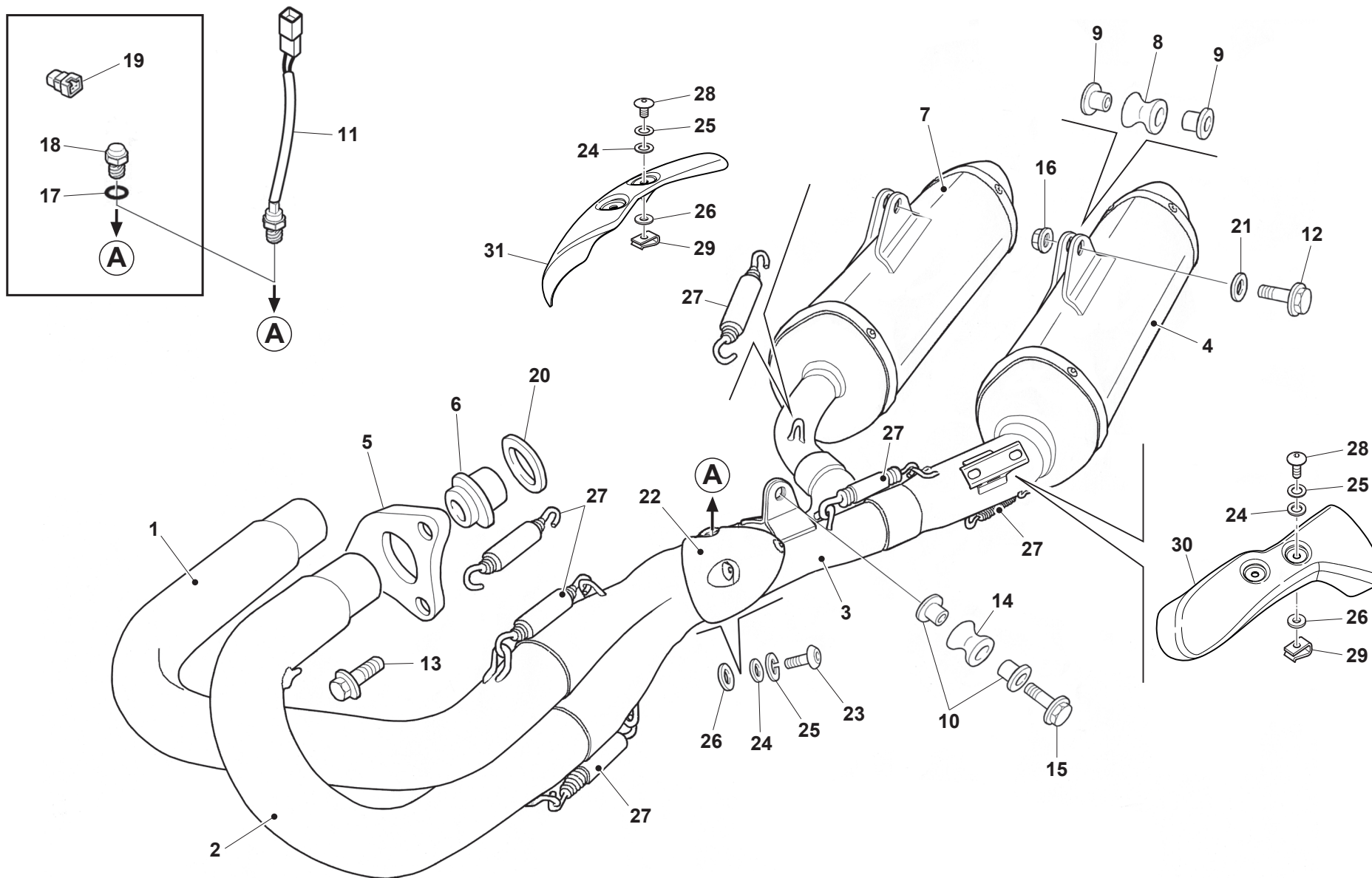



RS 300R/2016
RS 500R/2016
SM 500R/2016

SCARICO - EXHAUST SYSTEM
TUYAU D'ÉCHAPPEMENT - AUSPUFFROHR
TUBO DE ESCAPE

TAVOLA
DRAWING
TABLE
BILD
TABLA

27

Note Notes Notes Marke Notas	Pos. No. N. Index Pos.	N. Cod. Code No. Nr. Code Code Nr N. Cod.	Q.tà Q.ty Q.te M.ge C.ad	DENOMINAZIONE	NAME	DESIGNATION	BESHREIBUNG	DENOMINACION
RS 300R	1	F000P00145	1	TUBO SCARICO DESTRO	EXHAUST PIPE, RH	TUYAU ECHAPPEMENT DROIT	AUSPUFFROHR, RECHTS	TUBERIA ESCAPE DERECHO
RS 500R - SM 500R	1	F000P00267	1	TUBO SCARICO DESTRO	EXHAUST PIPE, RH	TUYAU ECHAPPEMENT DROIT	AUSPUFFROHR, RECHTS	TUBERIA ESCAPE DERECHO
RS 300R	2	F000P00144	1	TUBO SCARICO SINISTRO	PIPE, EXHAUST LH	TUYAU ECHAPPEMENT GAUCHE	AUSPUFFROHR, LINKS	TUBERIA ESCAPE IZQUERDO
RS 500R - SM 500R	2	F000P00268	1	TUBO SCARICO SINISTRO	PIPE, EXHAUST LH	TUYAU ECHAPPEMENT GAUCHE	AUSPUFFROHR, LINKS	TUBERIA ESCAPE IZQUERDO
	3	F000P00269	1	COLLETTORE SCARICO	EXHAUST MANIFOLD	COLLECTEUR ECHAPPEMENT	AUSPUFFKRUEMMER	TUBERIA ESCAPE
	4	F000P00756	1	SILENZIATORE SINISTRO	SILENCER, LEFT	SILENCIEUX GAUCHE	SCHALLDAEMPFER, LINKS	SILENCIADOR IZQUERDO
	5	8000A0870	2	FLANGIA SCARICO	HOLDER-EXHAUST PIPE	BRIDE ECHAPPEMENT	FLANSCH AUSPUFFROHR	BRIDA TUBERIA ESCAPE
RS 300R	6	8000A0871	2	BOCCOLA	BUSH	DOUILLE	BUCHSE	BUJE
RS 500R - SM 500R	6	8000A0893	2	BOCCOLA	BUSH	DOUILLE	BUCHSE	BUJE
	7	F000P00757	1	SILENZIATORE DESTRO	SILENCER, RH	SILENCIEUX DROIT	SCHALLDAEMPFER, RECHTS	SILENCIADOR DERECHO
	8	800089302	2	SILENTBLOCK	DAMPER	SILENTBLOC	SCHWINGUNGSDAEMPFER	CASQUILLO ELASTICO
	9	8C00A7729	4	DISTANZIALE	SPACER	ENTRETOISE	ABSTANDHALTER	DISTANCIADOR
	10	8000B0263	2	DISTANZIALE	SPACER	ENTRETOISE	ABSTANDHALTER	DISTANCIADOR
	11	F000P00579	1	SENSORE OSSIGENO	SENSOR, OXYGEN	CAPTEUR OXYGENE	ABTASTER SAUERSTOFF	SENSOR OXYGENO
	12	ZE0067545	2	VITE TEF M6X1,00X40 CH8	SCREW TEF M6X1.00X40 CH8	VIS TEF M6X1,00X40 CH8	SCHRAUBE TEF M6X1,00X40 CH8	TORNILLO TEF M6X1,00X40 CH8
	13	Z00062726	4	VITE TEF M6X1,00X14 CH8	SCREW TEF M6X1.00X14 CH8	VIS TEF M6X1,00X14 CH8	SCHRAUBE TEF M6X1,00X14 CH8	TORNILLO TEF M6X1,00X14 CH8
	14	8000H0064	1	SILENTBLOCK	DAMPER	SILENTBLOC	SCHWINGUNGSDAEMPFER	CASQUILLO ELASTICO
	15	ZA0067545	1	VITE TEF M6X1,00X35 CH8	SCREW TEF M6X1.00X35 CH8	VIS TEF M6X1,00X35 CH8	SCHRAUBE TEF M6X1,00X35 CH8	TORNILLO TEF M6X1,00X35 CH8
	16	Z00044240	2	DADO AUTOBLOCCANTE M6X1 CH10	NUT, SELF LOCKING M6X1 CH10	ECROU AUTOBLOQUANT M6X1 CH10	SELBSTSPERRENDE MUTTER M6X1 CH10	TUERCA AUTOBLOQUEANTE M6X1 CH10
	17	8000A7749	1	GUARNIZIONE	GASKET	JOINT	DICHTUNG	JUNTA
	18	F000P00577	1	TAPPO SENSORE OSSIGENO	PLUG SENSOR, OXYGEN	BOUCHON CAPTEUR OXYGENE	VERSCHLUSS ABTASTER SAUERSTOFF	TAPON SENSOR OXYGENO
	19	8000A6750	1	CONNETTORE SENSORE OSSIGENO	CONNECTOR SENSOR, OXYGEN	CONNECTEUR CAPTEUR OXYGENE	STECKER ABTASTER SAUERSTOFF	CONECTOR SENSOR OXYGENO
RS 300R	20	8000A0873	2	GUARNIZIONE SCARICO	GASKET, EXHAUST PIPE	JOINT TUYAU ECHAPPEMENT	DICHTUNG, AUSPUFFROHR	JUNTA TUBERIA ESCAPE
RS 500R - SM 500R	20	8A00A0873	2	GUARNIZIONE SCARICO	GASKET, EXHAUST PIPE	JOINT TUYAU ECHAPPEMENT	DICHTUNG, AUSPUFFROHR	JUNTA TUBERIA ESCAPE
	21	800022271	2	RONDELLA 20X6,4X1,5	WASHER 20X6.4X1.5	RONDELLE 20X6,4X1,5	SCHEIBE 20X6,4X1,5	ARANDELA 20X6,4X1,5
	22	8000B0269	1	PROTEZIONE COLLETTORE SCARICO	COVER, EXHAUST PIPE	PROTECTION TUYAU ECHAPPEMENT	AUSPUFFROHRSCHUTZ	PROTECCION TUBERIA ESCAPE
	23	Z00055699	2	VITE TCEI M6X1X10	SCREW TCEI M6X1X10	VIS TCEI M6X1X10	SCHRAUBE TCEI M6X1X10	TORNILLO TCEI M6X1X10
	24	62N115504	6	RONDELLA 12X6,4X1	WASHER 12X6.4X1	RONDELLE 12X6,4X1	SCHEIBE 12X6,4X1	ARANDELA 12X6,4X1
	25	62N115778	6	RONDELLA 12X6,4X0,5	WASHER 12X6.4X0.5	RONDELLE 12X6,4X0,5	SCHEIBE 12X6,4X0,5	ARANDELA 12X6,4X0,5
	26	800035112	6	RONDELLA ISOLANTE 14X5,5X2 mm	INSULATING WASHER 14X5.5X2 mm	RONDELLE ISOLANTE 14X5,5X2 mm	ISOLIERSCHEIBE 14X5,5X2 mm	ARANDELA AISLANTE 14X5,5X2 mm
	27	8000A1239	6	MOLLA SCARICO	SPRING, EXHAUST PIPE	RESSORT ANCRAGE TUYAU ECHAPPEMENT	FEDER AUSPUFFROHRBEFESTIGUNG	MUELLE ANCLAJE TUBERIA ESCAPE
	28	800055703	4	VITE TCEI M6X1X14	SCREW TCEI M6X1X14	VIS TCEI M6X1X14	SCHRAUBE TCEI M6X1X14	TORNILLO TCEI M6X1X14
	29	U00046893	4	DADO A GRAFFETTA M6X1	CLIP NUT M6X1	ECROU D'AGRAFE M6X1	FEDERMUTTER M6X1	TUERCA DE CLIP M6X1

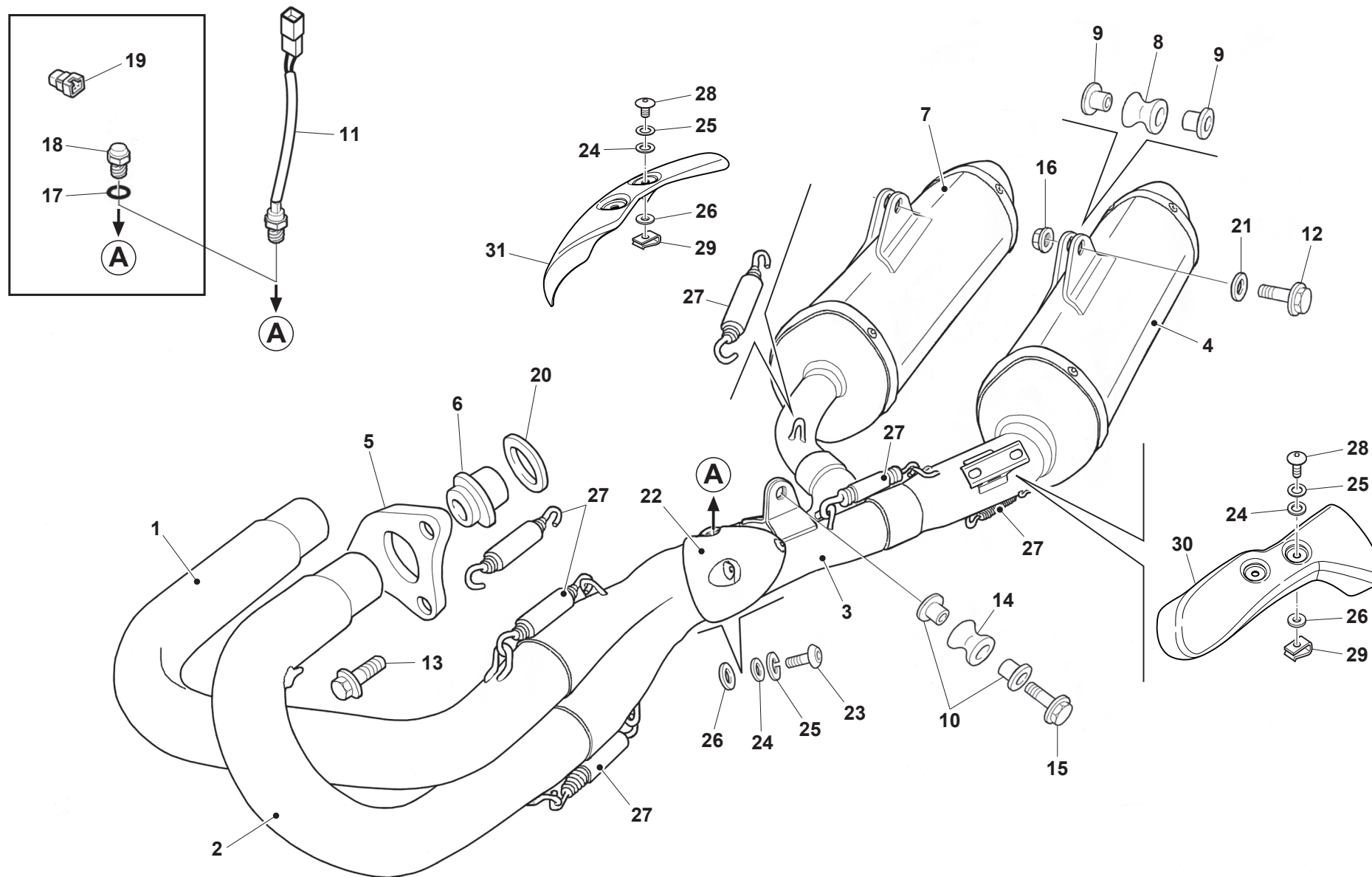

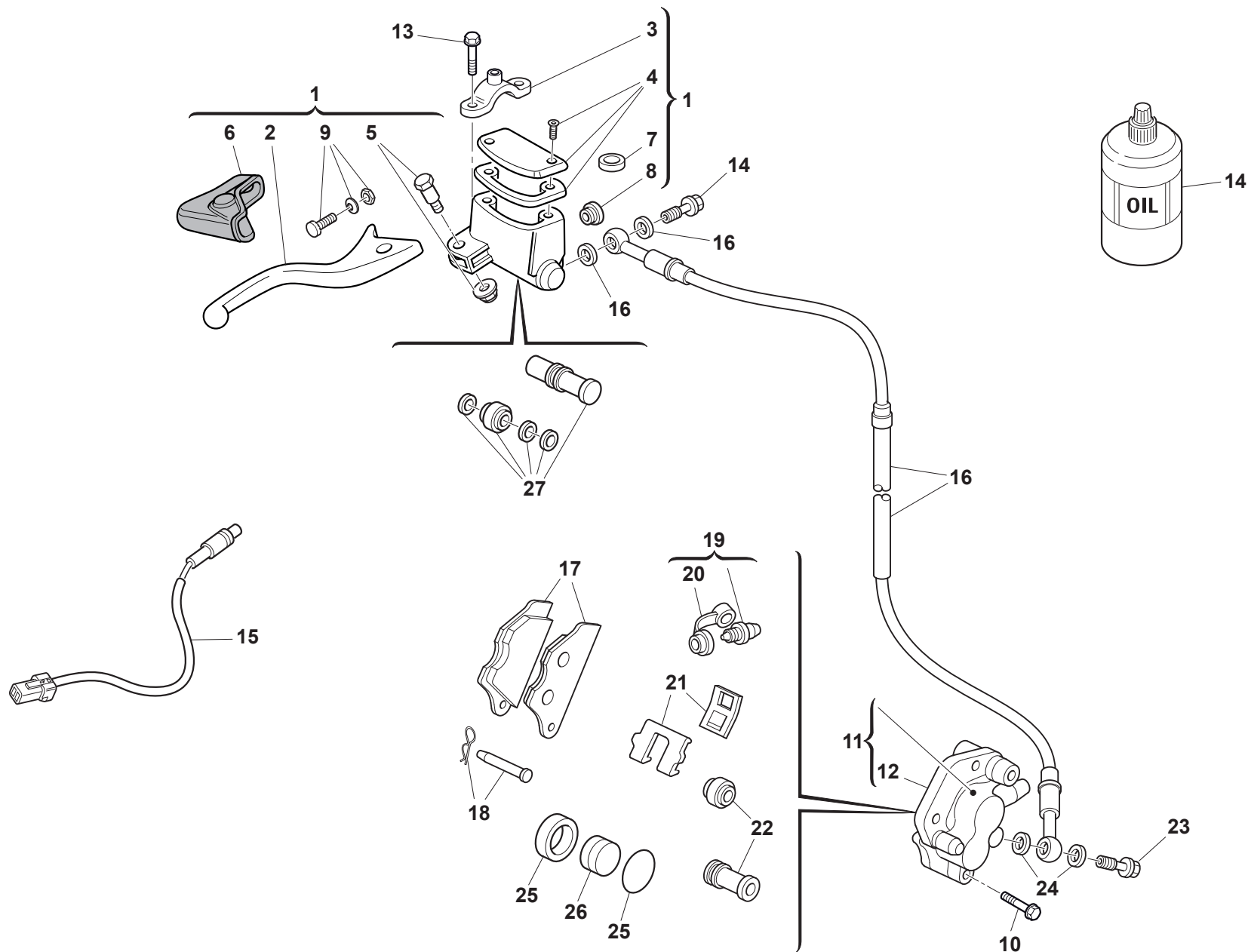



RS 300R/2016
RS 500R/2016

FRENO IDRAULICO ANTERIORE - FRONT HYDRAULIC BRAKE
FREIN HYDRAULIQUE AVANT - VORDERBREMSE
FRENO HIDRAULICO DELANTERO

TAVOLA
DRAWING
TABLE
BILD
TABLA

28

Note Notes Notes Marke Notas	Pos. No. Index Pos.	N. Cod. Code No. Nr. Code Code Nr N. Cod.	Q.tà Q.ty Q.te M.ge C.ad	DENOMINAZIONE	NAME	DESIGNATION	BESHREIBUNG	DENOMINACION
	1	8000A9348	1	POMPA FRENO ANTERIORE	CYLINDER, FRONT MASTER	MAITRE CYLINDRE FREIN AVANT	HAUPTZYLINDER, VORNE	BOMBA FRENO DELANTERO
	2	8000A4564	1	LEVA FRENO ANTERIORE	LEVER, FRONT BRAKE	LEVIER FREIN AVANT	BREMSHEBEL VORNE	PALANCA FRENO DELANTERO
	3	8000A4568	1	CAVALLOTTO POMPA FRENO	BRACKET, MASTER CYLINDER	BRIDE MAITRE CYLINDRE	KONSOLE, HAUPTBREMSZYLINDER	BRIDA BOMBA FRENO
	4	800094126	1	COPERCHIO VASCHETTA LIQUIDO FRENI	COVER MASTER CYLINDER	COUVERCLE RESERVOIR LIQUIDE FREIN	VERSCHLUSS BREMSFLUESSIGKEITTANK	TAPON DEPOSITO LIQUIDO FRENOS
	5	800094127	1	PERNO LEVA FRENO	BOLT, HANDLE LEVER PIVOT	PIVOT LEVIER FREIN	HEBELSCHRAUBE KPL.	PERNO PALANCA FRENO
	6	800094128	1	SOFFIETTO POMPA FRENO	DUST COVER	SOUFFLET EN CAOUTCHOUC	GUMMIBALG	FUELLE GOMA
	7	800079099	1	ANTIEMULSIONANTE	ANTIEMULSION	ANTIEMULSION	EMULSIONWIDRIGER	ANTIEMULSION
	8	800049654	1	VETRINO SPIA LIVELLO OLIO	WINDOW, OIL LEVEL CHECK	HUBLOT NIVEAU HUILE	SCHAUGLAS, OELKONTROLL	MIRILLA NIVEL ACEITE
	9	8000A9349	1	VITE REGISTRO LEVA	ADJUSTING SCREW	VIS REGLAGE	EINSTELLSCHRAUBE	TORNILLO REGULACION
	10	ZA0062733	2	VITE TE M8X1,25X40	SCREW TE M8X1,25X40	VIS TE M8X1,25X40	SCHRAUBE TE M8X1,25X40	TORNILLO TE M8X1,25X40
	11	8000H0768	1	PINZA FRENO ANTERIORE	CALIPER, FRONT BRAKE	ETRIER FREIN AVANT	BREMSSATTEL, VORNE	PINZA FRENO DELANTERO
	12	8000A7145	1	SUPPORTO PINZA FRENO ANTERIORE	BRACKET, FRONT CALIPER	SUPPORT ETRIER FREIN AVANT	HALTERUNG, VORNEBREMSESATTEL	SOPORTE PINZA FRENO DELANTERO
	13	Z00062729	2	VITE TEF M6X1X25 CH8	SCREW TEF M6X1X25 CH8	VIS TEF M6X1X25 CH8	SCHRAUBE TEF M6X1X25 CH8	TORNILLO TEF M6X1X25 CH8
	14	A000P00720	1	LIQUIDO FRENI	BRAKE FLUID	LIQUIDE FREIN	BREMSFLUESSIGKEIT	LIQUIDO FRENO
	15	8000A0929	1	INTERRUTTORE STOP	SWITCH, STOP	INTERRUPTEUR STOP	STOPSCHALTER	INTERRUPTOR STOP
	16	8A00A6242	1	TUBO FRENO ANTERIORE	HOSE, FRONT BRAKE	TUYAU FREIN AVANT	BREMSSCHLAUCH VORNE	MANGUERA FRENO DELANTERO
	17	8000A7143	1	COPPIA PASTIGLIE FRENO ANTERIORE	PADS SET, FRONT BRAKE	JEU PLAQUETTES FREIN AVANT	VORNEBREMSBELAEGESATZ	JUEGO PASTILLAS FRENO DELANTERO
	18	8000A0932	1	GRUPPO REVISIONE PERNI PASTIGLIE FRENO	PAD PINS OVERHAUL SET	GROUPE REVISION PIVOTS PLAQUETTE	BREMSBELAEGEN EBERHOLUNGSGRUPPE	GRUPO REVISION PERNO PASTILLAS FRENO
	19	8000A0931	1	VITE SPURGO PINZA FRENO	BLEED SCREW KIT	VIS VIDANGE ETRIER FREIN	SCHRAUBE, BREMSSATTEL ABLASS	TORNILLO PURGA PINZA FRENO
	20	800053259	1	CAPPUCCIO VITE SPURGO	CAP, BLEEDER SCREW	CAPUCHON VIS RENIFLARD	ENTLUEFTUNGSKAPPE	CAPUCHON TORNILLO PURGA PINZA
	21	8000A7144	1	MOLLETTE PASTIGLIE FRENO	SUPPORT, PAD	RESSORT PLAQUETTE FREIN	FEDER, BREMSSESHEIBE	MUELLE PASTILLAS
	22	800079066	1	SERIE SILENTBLOCK PINZA FRENO	CAPS OVERHAUL SET	GROUPE REVISION CAPOUCHONS	GUMMIUBERARBEITUNGSZAZ	GRUPO REVISION GORRO
	23	U00057155	2	VITE RACCORDO TUBO M10X1,00X19	BOLT, BRAKE HOSE M10X1,00X19	VIS FIXATION TUYAU M10X1,00X19	FIXIERSCHRAUBE M10X1,00X19	TORNILLO FIJACION MANGUERA M10X1,00X19
	24	800021480	4	RONDELLA 14X10,2X1,5	WASHER 14X10,2X1,5	RONDELLE 14X10,2X1,5	SCHEIBE 14X10,2X1,5	ARANDELA 14X10,2X1,5
	25	8000A1139	1	SERIE GUARNIZIONI PINZA FRENO	BRAKE CALIPER OVERHAUL SET	JEU JOINTS ETRIER DU FREIN	BREMSSATTEL EBERHOLUNGSSATZ	JUEGO JUNTAS PINZA FRENO
	26	8000A1138	1	PISTONCINO PINZA FRENO	PISTON, CALIPER	PISTON ETRIER FREIN	KOLBEN BREMSSATTEL	PISTON PINZA FRENO
	27	8000A9350	1	PISTONCINO POMPA FRENO	CYLINDER KIT, MASTER	PISTON MAITRE CYLINDRE	KOLBEN, BREMSEPUMPE	PISTON BOMBA FRENO

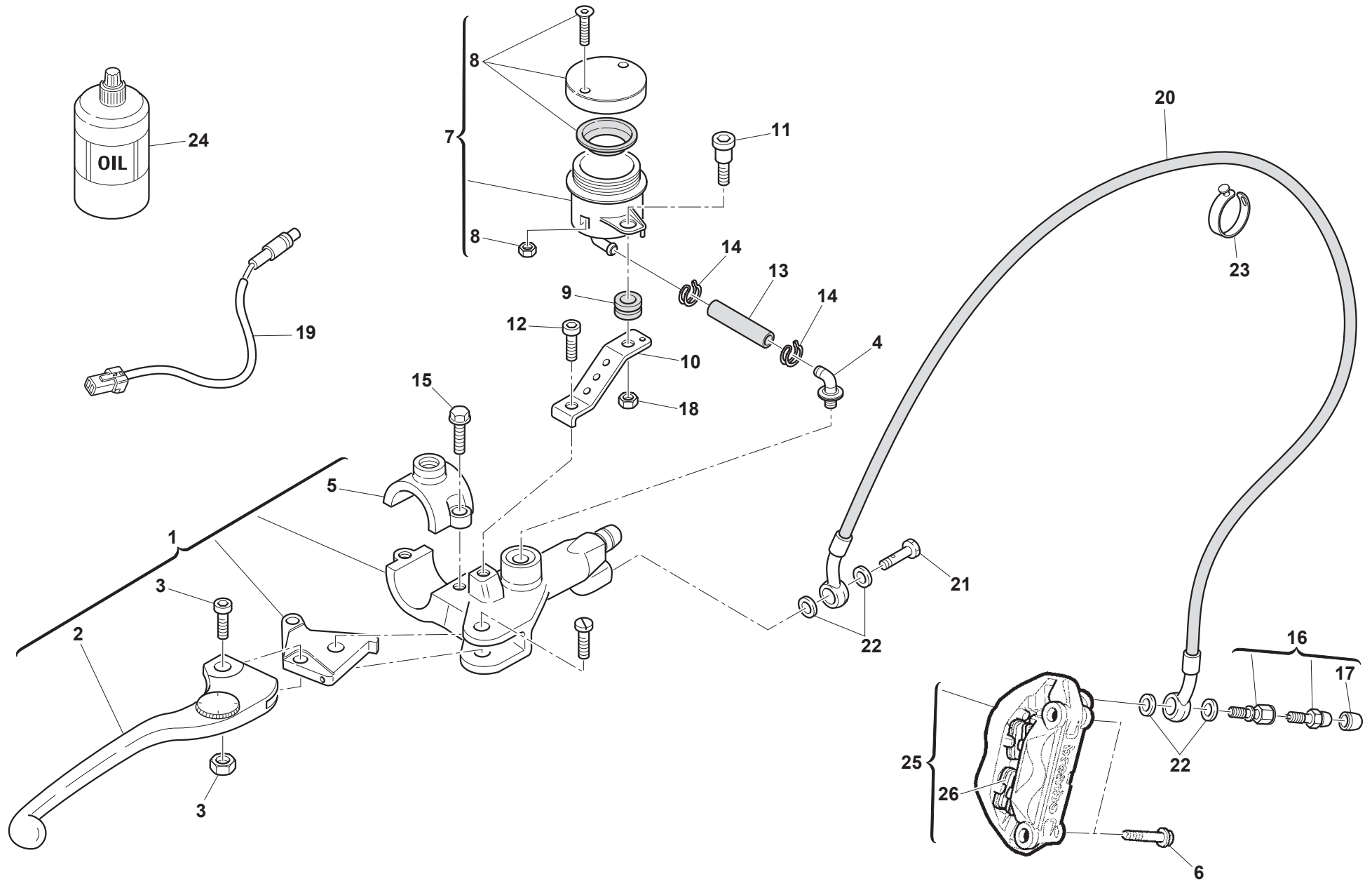



SM 500R/2016

FRENO IDRAULICO ANTERIORE - FRONT HYDRAULIC BRAKE
FREIN HYDRAULIQUE AVANT - VORDERBREMSE
FRENO HIDRAULICO DELANTERO

TAVOLA
DRAWING
TABLE
BILD
TABLA

28A

Note Notes Notas	Pos. No. Index Pos.	N. Cod. Code No. Nr. Code Code Nr N. Cod.	Q.tà Q.ty Q.te M.ge C.ad	DENOMINAZIONE	NAME	DESIGNATION	BESHREIBUNG	DENOMINACION
	1	8000A6076	1	POMPA FRENO ANTERIORE	FRONT MASTER CYLINDER	MAÎTRE-CYLINDRE DE FREIN AVANT	HAUPTBREMSZYLINDER VORNE	BOMBA FRENO DELANTERO
	2	8000A7146	1	LEVA FRENO ANTERIORE	LEVER, FRONT BRAKE	LEVIER FREIN AVANT	BREMSHEBEL VORNE	PALANCA FRENO DELANTERO
	3	8000A7148	1	GRUPPO REVISIONE PERNO LEVA	LEVER PIN SET	GROUPE DE RÉVISION AXE LEVIER	HEBELBOLZENSATZ	GRUPO REVISIÓN EJE PALANCA
	4	800042345	1	RACCORDO TUBO	UNION, HOSE	JOINT TUYAU	VERBINDUNG, SCHLAUCH	RACOR MANGUITO
	5	8000A7147	1	CAVALLOTTO POMPA FRENO	BRACKET, MASTER CYLINDER	BRIDE MAITRE CYLINDRE	KONSOLE, HAUPTBREMSZYLINDER	BRIDA BOMBA FRENO
	6	YS0082751	2	VITE TCEIF M10X1,25X55	SCREW TCEIF M10X1.25X55	VIS TCEIF M10X1,25X55	SCHRAUBE TCEIF M10X1,25X55	TORNILLO TCEIF M10X1,25X55
	7	800066181	1	VASCHETTA LIQUIDO FRENI	RESERVOIR, BRAKE FLUID	RESERVOIR LIQUIDE FREINS	BREMSFLUESSIGKEITANK	DEPOSITO LIQUIDO FRENO
	8	800068490	1	TAPPO VASCHETTA LIQUIDO FRENI	CAP BRAKE FLUID TANK	BOUCHON RESERVOIR LIQUIDE FREIN	VERSCHLUSS BREMSFLUESSIGKEITANK	TAPON DEPOSITO LIQUIDO FRENO
	9	800033288	1	SILENTBLOCK 20X10X13	DAMPER 20X10X13	SILENTBLOC 20X10X13	SCHWINGSDAEMPFER 20X10X13	CASQUILLO ELASTICO 20X10X13
	10	8000A6229	1	PIASTRINA	PLATE	PLAQUETTE	PLÄTTCHEN	PLACA
	11	8000A1189	1	VITE TTEI M5X16	SCREW TTEI M5X16	VIS TTEI M5X16	SCHRAUBE TTEI M5X16	TORNILLO TTEI M5X16
	12	Z00062725	1	VITE TEF M6X1,00X10 CH8	SCREW TEF M6X1.00X10 CH8	VIS TEF M6X1,00X10 CH8	SCHRAUBE TEF M6X1,00X10 CH8	TORNILLO TEF M6X1,00X10 CH8
	13	8G0066179	1	TUBO OLIO	OIL PIPE	TUYAU D'HUILE	ÖLROHR	TUBO ACEITE
	14	800018921	2	ANELLO ELASTICO 10 mm	CIRCLIP 10 mm	BAGUE ELASTIQUE 10 mm	SPRENGRING 10 mm	ANILLO ELASTICO 10 mm
	15	Z00062729	2	VITE TEF M6X1X25 CH8	SCREW TEF M6X1X25 CH8	VIS TEF M6X1X25 CH8	SCHRAUBE TEF M6X1X25 CH8	TORNILLO TEF M6X1X25 CH8
	16	8000A3975	1	VITE RACCORDO TUBO OLIO	BOLT, OIL PIPE	VIS FIXATION TUYAU HUILE	FIXIERSCHRAUBE OELSCHLAUCH	TORNILLO FIJACION TUBO ACEITE
	17	800053259	1	CAPPUCCIO VITE SPURGO	CAP, BLEEDER SCREW	CAPUCHON VIS RENIFLARD	ENTLUEFTUNGSKAPPE	CAPUCHON TORNILLO PURGA PINZA
	18	Z00056443	1	DADO AUTOBLOCCANTE M5X0,8 CH8	NUT, SELF LOCKING M5X0.8 CH8	ECROU AUTOBLOQUANT M5X0,8 CH8	SELBSTSPERRENDE MUTTER M5X0,8 CH8	TUERCA AUTOBLOQUEANTE M5X0,8 CH8
	19	8000A0929	1	INTERRUTTORE STOP	STOP SWITCH	INTERRUPTEUR STOP	BREMSLICHTSCHALTER	INTERRUPTOR FRENO
	20	F000P00569	1	TUBO FRENO ANTERIORE	FRONT BRAKE TUBE	TUYAU DE FREIN AVANT	ROHR VORDERRADBREMSE	TUBO FRENO DELANTERO
	21	U00057155	1	VITE RACCORDO TUBO M10X1,00X19	BOLT, BRAKE HOSE M10X1.00X19	VIS FIXATION TUYAU M10X1,00X19	FIXIERSCHRAUBE M10X1,00X19	TORNILLO FIJACION MANGUERA M10X1,00X19
	22	800021480	4	RONDELLA 14X10,2X1 mm	WASHER 14X10.2X1 mm	RONDELLE 14X10,2X1 mm	SCHEIBE 14X10,2X1 mm	ARANDELA 14X10,2X1 mm
	23	800092668	4	FASCETTA	CLAMP	COLLIER	SHELLE	ABRAZADERA
	24	A000P00720	1	LIQUIDO FRENI	BRAKE FLUID	LIQUIDE FREIN	BREMSFLUESSIGKEIT	LIQUIDO FRENO
	25	8000A6078	1	PINZA FRENO ANTERIORE	FRONT BRAKE CALLIPER	ETRIER DE FREIN	BREMSSATTEL	PINZA FRENO
	26	8000A2040	1	COPIA PASTIGLIE FRENO ANTERIORE	PADS SET, FRONT BRAKE	JEU PLAQUETTES FREIN AVANT	VORNEBREMSBELAEGESATZ	JUEGO PASTILLAS FRENO DELANTERO

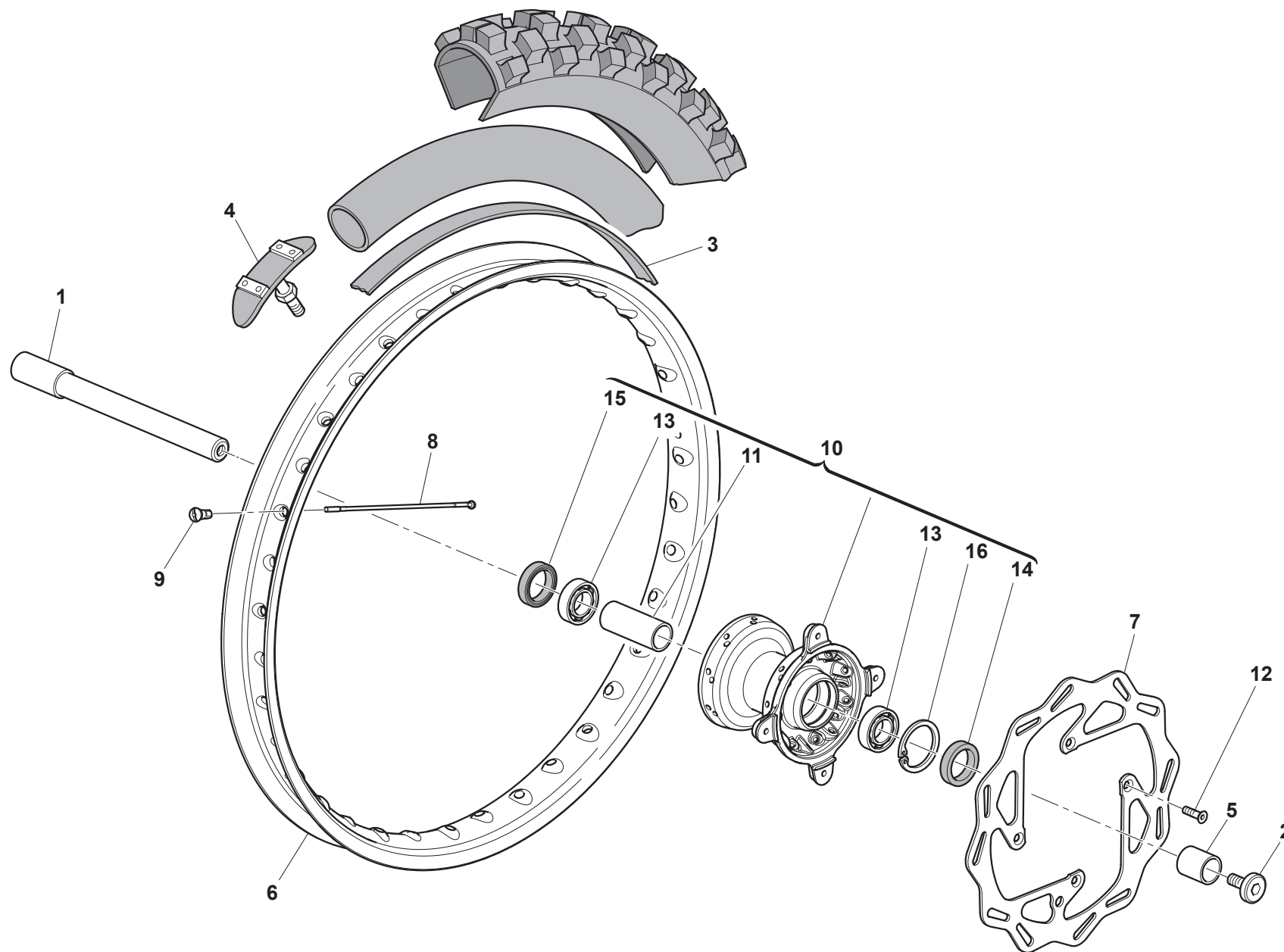



RS 300R/2016
RS 500R/2016

RUOTA ANTERIORE - FRONT WHEEL
ROUE AV. - VORTERRAD
RUEDA DELANTERA

TAVOLA
DRAWING
TABLE
BILD
TABLA

29

Note Notes Notes Marke Notas	Pos. No. Index Pos.	N. Cod. Code No. Nr. Code Code Nr N. Cod.	Q.tà Q.ty Q.te M.ge C.ad	DENOMINAZIONE	NAME	DESIGNATION	BESHREIBUNG	DENOMINACION
	1	FA00P00058	1	PERNO RUOTA ANTERIORE	AXLE, FRONT WHEEL	AXE ROUE AVANT	VORDERRADACHSE	EJE RUEDA DELANTERA
	2	800096933	1	VITE M20	SCREW M20	VIS M20	SCHRAUBE M20	TORNILLO M20
	3	800013346	1	FASCIA SALVACAMERA	PROTECTOR, INNER TUBE	FOND JANTE	FELGENBAND	PROTECTOR CAMARA
	4	800049036	1	FERMACOPERTONE	TIRE BLEND CLAMP	PLAQUE ARRET PNEU	REIFEN FIXIERPLATTE	PLACA SUJECION NEUMATICO
	5	8A0096930	1	DISTANZIALE	SPACER	ENTRETOISE	ABSTANDHALTER	DISTANCIADOR
	6	F000P00259	1	CERCHIO RUOTA ANTERIORE 1,6X21"	RIM, FRONT WEHEL 1.6X21"	JANTE ROUE AVANT 1,6X21"	FELGE, VORDERRAD 1,6X21"	LLANTA RUEDA DELANTERA 1,6X21"
	7	800099632	1	DISCO FRENO ANTERIORE	DISC, FRONT BRAKE	DISQUE FREIN AVANT	BREMSSSCHEIBE, VORNE	DISCO FRENO DELANTERO
	8	8000H1362	36	RAGGIO RUOTA ANTERIORE	SPOKE, FRONT WHEEL	RAYON ROUE AVANT	SPEICHE, VORDERRAD	RADIO RUEDA DELANTERA
	9	8000A6208	36	NIPPLO RAGGIO	NIPPLE, SPOKE	ECROU RAYON	NIPPEL, SPEICHE	TUERCA RADIO
	10	F000A00091	1	MOZZO RUOTA ANTERIORE	HUB, FRONT WHEEL	MOYEU ROUE AVANT	RADNABE, VORNE	CUBO RUEDA DELANTERA
	11	F000P00120	1	DISTANZIALE INTERNO CUSCINETTI	SPACER, HUB BEARING	ENTRETOISE INTERNE ROULEMENT	KUGELLAGER INNEREABSTANDHALTER	DISTANCIADOR INTERIOR COJINETE
	12	YA0055241	4	VITE TCEI M6X1,00X14 CH5	SCREW TCEI M6X1.00X14 CH5	VIS TCEI M6X1,00X14 CH5	SCHRAUBE TCEI M6X1,00X14 CH5	TORNILLO TCEI M6X1,00X14 CH5
	13	800084938	2	CUSCINETTO A SFERE 25X42X9	BEARING, BALL 25X42X9	ROULEMENT A BILLES 25X42X9	KUGELLAGER 25X42X9	COJINETE DE BOLAS 25X42X9
	14	800022966	1	PARAPOLVERE 32X42X7	SEAL, DUST 32X42X7	PARE POUSSIERE 32X42X7	STAUBDECKEL 32X42X7	GUARDAPOLVO 32X42X7
	15	8000H6187	1	PARAOILIO 42X28X7	OIL SEAL 42X28X7	BAGUE D'ETANCHEITE 42X28X7	WELLENDICHTRING 42X28X7	RETEN DE ACEITE 42X28X7
	16	66N021270	1	ANELLO SEEGER INTERNO 42mm DIN472	CIRCLIP 42mm DIN472	CIRCLIP 42mm DIN472	SEEGERRING 42mm DIN472	ANILLO SEEGER 42mm DIN472

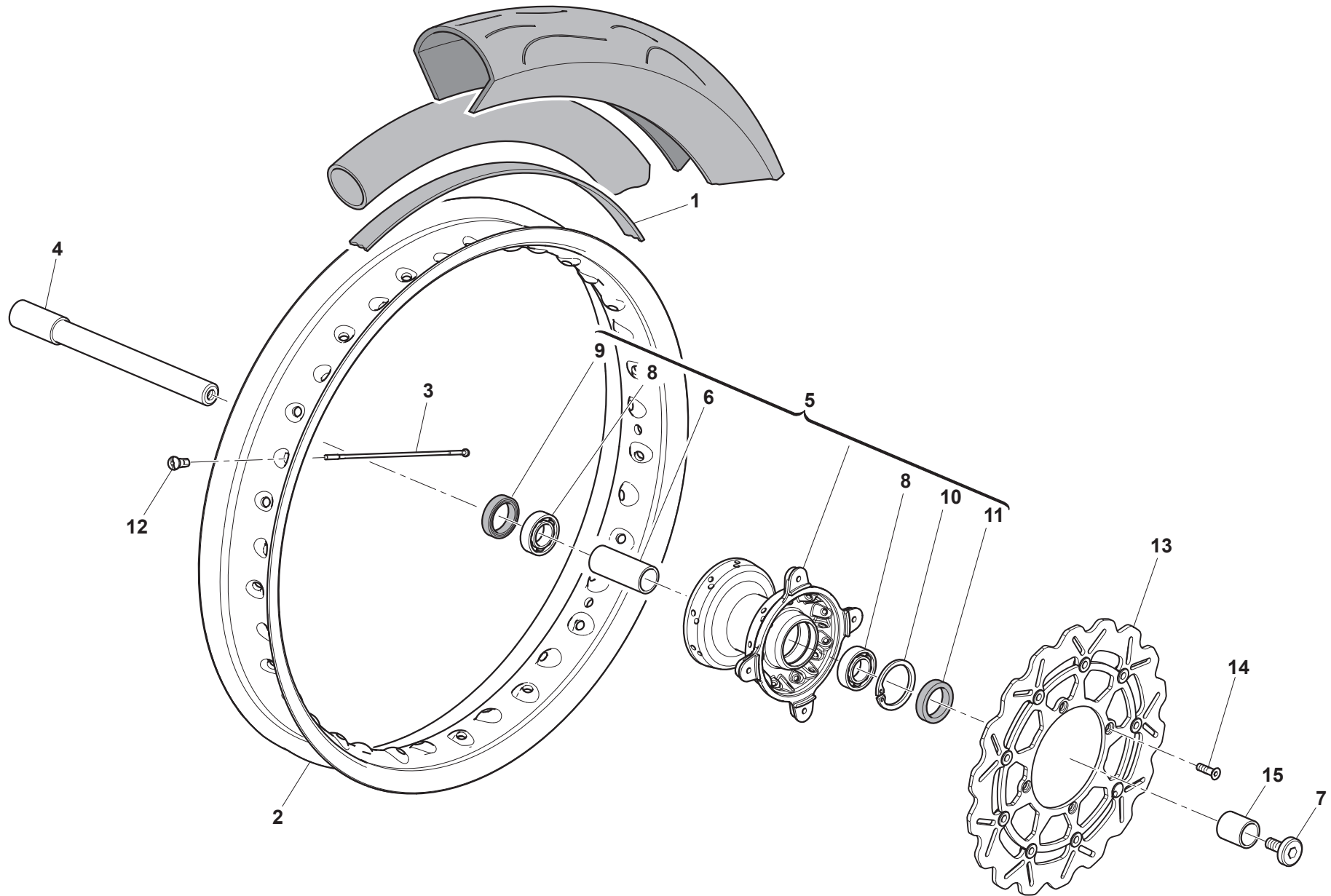

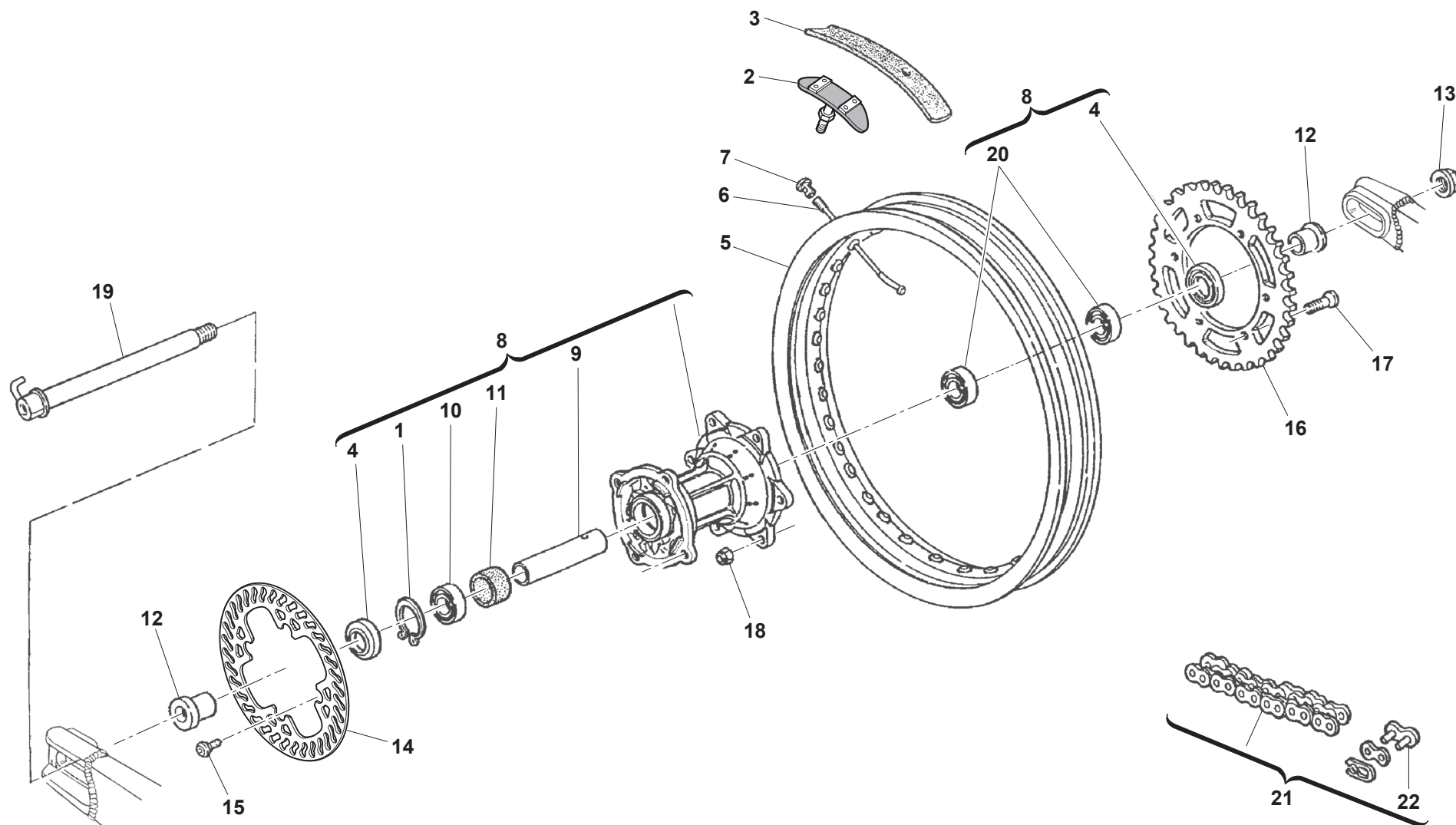



RS 300R/2016
RS 500R/2016
SM 500R/2016

RUOTA POSTERIORE - REAR WHEEL
ROUE ARRIERE - HINTERRAD
RUEDA TRASERA

TAVOLA
DRAWING
TABLE
BILD
TABLA

30

Note Notes Notes Marke Notas	Pos. No. N. Index Pos.	N. Cod. Code No. Nr. Code Code Nr N. Cod.	Q.tà Q.ty Q.te M.ge C.ad	DENOMINAZIONE	NAME	DESIGNATION	BESHREIBUNG	DENOMINACION
	1	66N021272	1	ANELLO ELASTICO 50,5 mm	CIRCLIP 50.5 mm	CIRCLIP 50,5 mm	SPRENGRING 50,5 mm	ANILLO ELASTICO 50,5 mm
RS 300R - RS 500R	2	800054073	1	FERMACOPERTONE	TIRE BLEND CLAMP	PLAQUE ARRET PNEU	REIFEN FIXIERPLATTE	PLACA SUJECION PNEUMATICO
RS 300R - RS 500R	3	800001688	1	FASCIA SALVACAMERA	PROTECTOR, INNER TUBE	FOND JANTE	FELGENBAND	PROTECTOR CAMARA
SM 500R	3	8B0082879	1	FASCIA SALVACAMERA	PROTECTOR, INNER TUBE	FOND JANTE	FELGENBAND	PROTECTOR CAMARA
	4	800089572	2	PARAOLIO 32X47X7	OIL SEAL 32X47X7	BAGUE D'ETANCHEITE 32X47X7	WELLENDICHRING 32X47X7	RETEN DE ACEITE 32X47X7
RS 300R - RS 500R	5	F000P00260	1	CERCHIO RUOTA POSTERIORE 2,15"X18"	RIM, REAR WHEEL 2,15"X18"	JANTE ROUE ARRIERE 2,15"X18"	FELGE, HINTENRAD 2,15"X18"	LLANTA RUEDA TRASERA 2,15"X18"
SM 500R	5	F000P00262	1	CERCHIO RUOTA POSTERIORE 4,25"X17"	RIM, REAR WHEEL 4,25"X17"	JANTE ROUE ARRIERE 4,25"X17"	FELGE, HINTENRAD 4,25"X17"	LLANTA RUEDA TRASERA 4,25"X17"
RS 300R - RS 500R	6	8000H1533	18	RAGGIO RUOTA POSTERIORE LATO DISCO	REAR WHEEL SPOKE, DISC SIDE	RAYON ROUE ARRIERE COTE DISQUE	HINTERRADSPEICHE SCHEIBE SEITE	RADIO RUEDA TRASERA LATO DISCO
RS 300R - RS 500R	6	8000H1534	18	RAGGIO RUOTA POSTERIORE LATO CORONA	REAR WHEEL SPOKE, SPROCKET SIDE	RAYON ROUE ARRIERE COTE COURONNE	HINTERRADSPEICHE ZAHNKETTENRAD SEITE	RADIO RUEDA TRASERA LATO CORONA
SM 500R	6	8000H1725	18	RAGGIO RUOTA POSTERIORE LATO DISCO	REAR WHEEL SPOKE, DISC SIDE	RAYON ROUE ARRIERE COTE DISQUE	HINTERRADSPEICHE SCHEIBE SEITE	RADIO RUEDA TRASERA LATO DISCO
SM 500R	6	8000H1726	18	RAGGIO RUOTA POSTERIORE LATO CORONA	REAR WHEEL SPOKE, SPROCKET SIDE	RAYON ROUE ARRIERE COTE COURONNE	HINTERRADSPEICHE ZAHNKETTENRAD SEITE	RADIO RUEDA TRASERA LATO CORONA
SM 500R	7	69N429005	36	NIPPLO RAGGIO	NIPPLE, SPOKE	ECROU RAYON	NIPPEL, SPEICHE	TUERCA RADIO
RS 300R - RS 500R	7	8000A6209	36	NIPPLO RAGGIO ALPINA	NIPPLE, SPOKE ALPINA	ECROU RAYON ALPINA	NIPPEL, SPEICHE ALPINA	TUERCA RADIO ALPINA
	8	F000A00093	1	MOZZO RUOTA POSTERIORE	HUB, REAR WHEEL	MOYEU ROUE ARRIERE	RADNABE, HINTEN	CUBO RUEDA TRASERA
	9	800092414	1	DISTANZIALE INTERNO CUSCINETTI	SPACER, HUB BEARING	ENTRETOISE INTERNE ROULEMENT	KUGELLAGER INNEREABSTANDHALTER	DISTANCIADOR INTERIOR COJINETE
	10	8B0026846	1	CUSCINETTO A SFERE 25X47X16	BEARING, BALL 25X47X16	ROULEMENT A BILLES 25X47X16	KUGELLAGER 25X47X16	COJINETE DE BOLAS 25X47X16
	11	F000P00121	1	DISTANZIALE	SPACER	ENTRETOISE	ABSTANDHALTER	DISTANCIADOR
	12	800096938	2	DISTANZIALE ESTERNO	SPACER, OUTER	ENTRETOISE EXTERIEUR	ABSTANDHALTER, AUSSER	DISTANCIADOR EXTERIOR
	13	Y00093072	1	DADO M20X1,5 CH27	NUT M20X1.5 CH27	ECROU M20X1,5 CH27	MUTTER M20X1,5 CH27	TUERCA M20X1,5 CH27
	14	8000A4288	1	DISCO FRENO POSTERIORE	DISC REAR BRAKE	DISQUE FREIN ARRIERE	BREMSSCHEIBE, HINTEN	DISCO FRENO TRASERO
	15	Z00062726	4	VITE TEF M6X1X14	SCREW TEF M6X1X14	VIS TEF M6X1X14	SCHRAUBE TEF M6X1X14	TORNILLO TEF M6X1X14
SM 500R	16	8000A4859	1	CORONA Z42	REAR SPROCKET T42	COURRONE D42	ZAHNKETTENRAD Z42	CORONA D42
RS 500R	16	800096837	1	CORONA Z46	REAR SPROCKET T46	COURONNE D46	ZAHNKETTENRAD Z46	CORONA D46
RS 500R	16	8A0096837	1	CORONA Z47	REAR SPROCKET T47	COURONNE D47	ZAHNKETTENRAD Z47	CORONA D47
RS 300R	16	8D0096837	1	CORONA Z50	REAR SPROCKET T50	COURRONE D50	ZAHNKETTENRAD Z50	CORONA D50
	17	8000H0158	6	VITE SPECIALE TSEI M8X1,25X28 CH6	SCREW, SPECIAL TSEI M8X1.25X28 CH6	VIS SPECIAL TSEI M8X1,25X28 CH6	SPEZIALSCHRAUBE TSEI M8X1,25X28 CH6	TORNILLO ESPECIAL TSEI M8X1,25X28 CH6
	18	Y00043928	6	DADO	NUT	ÉCROU	MUTTER	TUERCA
	19	F000P00066	1	PERNO RUOTA POSTERIORE	AXLE, REAR WHEEL	AXE ROUE ARRIERE	HINTERRADACHSE	EJE RUEDA TRASERA
	20	8A0026846	2	CUSCINETTO A SFERE 6005	BEARING, BALL 6005	ROULEMENT A BILLES 6005	KUGELLAGER 6005	COJINETE DE BOLAS 6005
RS 300R	21	8000A6261	1	CATENA 135ORC6-112	CHAIN 135ORC6-112	CHAINE 135ORC6-112	KETTE 135ORC6-112	CADENA 135ORC6-112
RS 500R	21	8D00A6261	1	CATENA 135ORC6-110	CHAIN 135ORC6-110	CHAINE 135ORC6-110	KETTE 135ORC6-110	CADENA 135ORC6-110
SM 500R	21	8E00A6261	1	CATENA 135ORC6-108	CHAIN 135ORC6-108	CHAINE 135ORC6-108	KETTE 135ORC6-108	CADENA 135ORC6-108
	22	8000A6262	1	GIUNTO CATENA DID 520V6	CHAIN LINK DID 520V6	JOINT CHAINE DID 520V6	VERBINDUNG KETTE DID 520V6	RACORD CADENA DID 520V6

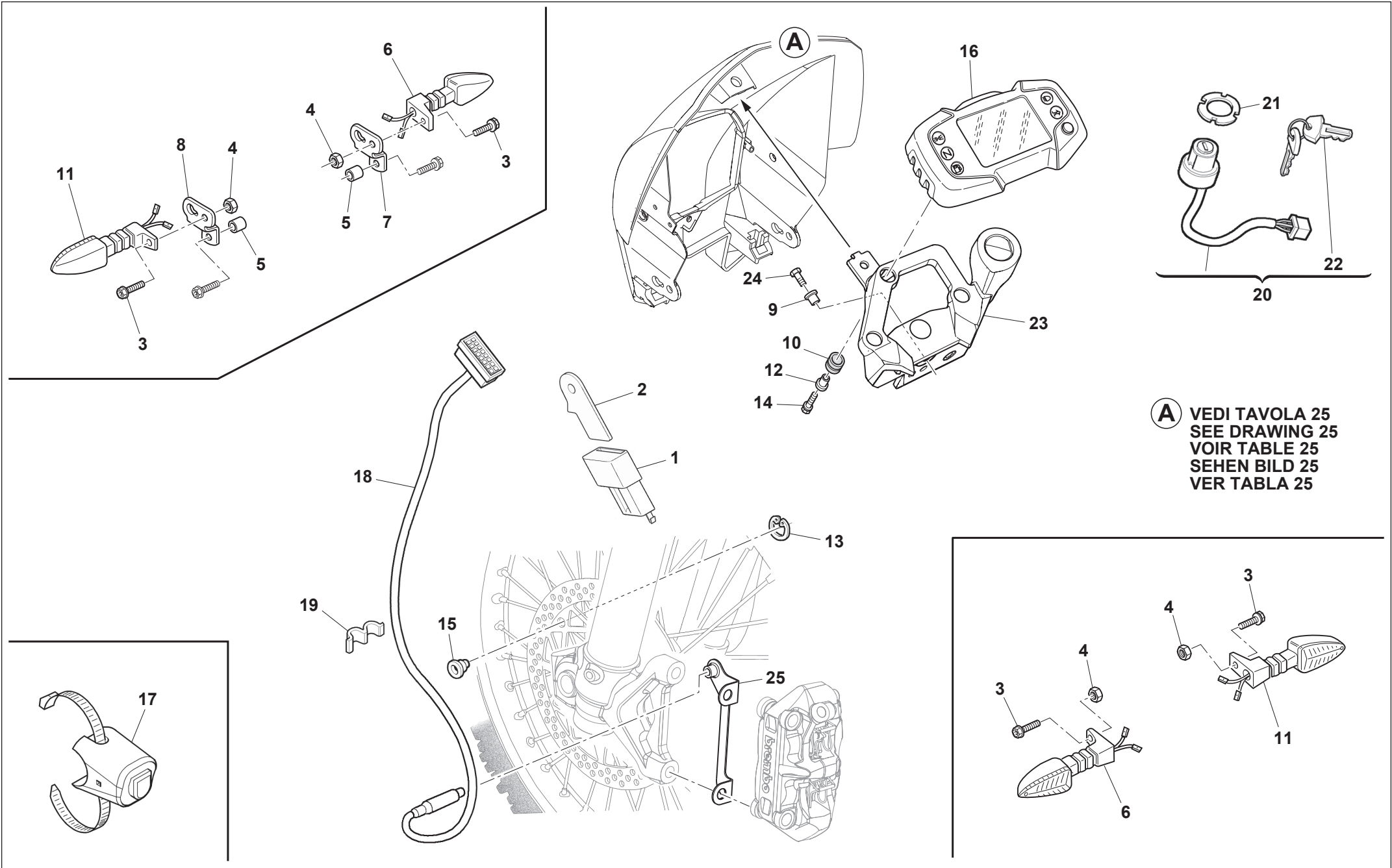

A VEDI TAVOLA 25
SEE DRAWING 25
VOIR TABLE 25
SEHEN BILD 25
VER TABLA 25



RS 300R/2016
RS 500R/2016
SM 500R/2016

STRUMENTO DIGITALE, INDICATORI DI DIREZIONE - DIGITAL INSTRUMENT, BLINKERS
INSTRUMENT DIGITAL, CLIGNOTANTS - DIGITAL TACHOMETER, BLINKERS
INSTRUMENTO DIGITAL, INTERMITENTES

TAVOLA
DRAWING
TABLE
BILD
TABLA

31

Note Notes Notas	Pos. No. Index Pos.	N. Cod. Code No. Nr. Code Code Nr N. Cod.	Q.tà Q.ty Q.te M.ge C.ad	DENOMINAZIONE	NAME	DESIGNATION	BESHREIBUNG	DENOMINACION
	1	8000H4202	1	INTERMITTENZA LAMPEGGIATORI	FLASHER RELAY	RELAIS CLIGNOTANTS	BLINKERRELAIS	RELE INTERMITENTES
	2	8000H1290	1	SUPPORTO INTERMITTENZA LAMPEGGIATORI	STAY FLASHER RELAY	SUPPORT, RELAIS CLIGNOTANTS	STUTZE, BLINKERRELAIS	SOPORTE RELE INTERMITENTES
	3	Z00062727	4	VITE TE M6X1X16 CH8	SCREW TE M6X1X16 CH8	VIS TE M6X1X16 CH8	SCHRAUBE TE M6X1X16 CH8	TORNILLO TE M6X1X16 CH8
	4	Z00044240	4	DADO AUTOBLOCCANTE M6X1 CH10	NUT, SELF LOCKING M6X1 CH10	ECROU AUTOBLOQUANT M6X1 CH10	SELBSTSPERRENDE MUTTER M6X1 CH10	TUERCA AUTOBLOQUEANTE M6X1 CH10
	5	8000A6638	2	DISTANZIALE	SPACER	ENTRETOISE	ABSTANDHALTER	DISTANCIADOR
	6	E000P00264	2	LAMPEGGIATORE ANT. DX - POST. SX	FLASHER LIGHT FRONT RH - REAR LH	CLIGNOTANT AVANT DROIT - ARRIERE GAUCHE	BLINKER, VORDER RECHTS RUECK LINKS	INTERMITENTE DEL.DERECHO -TRASERO IQZ.
	7	8000A6642	1	SUPPORTO LAMPEGGIATORE DESTRO	BRACKET, FLASHER LIGHT RH	SUPPORT CLIGNOTANT DROITE	BLINKER HALTERUNG, RECHTS	SOPORTE INTERMITENTE DERECHO
	8	8A00A6642	1	SUPPORTO LAMPEGGIATORE SINISTRO	BRACKET, FLASHER LIGHT LH	SUPPORT CLIGNOTANT GAUCHE	BLINKER HALTERUNG, LINKS	SOPORTE INTERMITENTE IZQUERDO
	9	800069282	1	BOCCOLA 14X7X5,25 mm	BUSH 14X7X5.25 mm	DOUILLE 14X7X5,25 mm	BUCHSE 14X7X5,25 mm	CASQUILLO 14X7X5,25 mm
	10	800095128	3	SILENTBLOCK	DAMPER	SILENTBLOC	SCHWINGUNGSDAEMPFER	CASQUILLO ELASTICO
	11	EA00P00264	2	LAMPEGGIATORE ANT. SX - POST. DX	FLASHER LIGHT FRONT LH - REAR RH	CLIGNOTANT AVANT GAUCHE - ARRIERE DROIT	BLINKER, VORDER LINKS RUECK RECHTS	INTERMITENTE DEL. IZQ.-TRASERO DERECHO
	12	8000B1774	3	BUSSOLA	BUSHING	DOUILLE	BUCHSE	CASQUILLO
SM 500R	13	66N021197	1	ANELLO SEEGER	CIRCLIP	CIRCLIP	SEEGERRING	ANILLO SEEGER
RS 300R - RS 500R	13	66N021200	1	ANELLO SEEGER	CIRCLIP	CIRCLIP	SEEGERRING	ANILLO SEEGER
	14	ZA0067997	2	VITE M5X16	SCREW M5X16	VIS M5X16	SCHRAUBE M5X16	TORNILLO M5X16
RS 300R - RS 500R	15	800099775	1	MAGNETE	MAGNET	AIMANT	MAGNET	IMAN
SM 500R	15	8000A0843	1	MAGNETE	MAGNET	AIMANT	MAGNET	IMAN
RS 300R - RS 500R	16	FA00P00185	1	TACHIMETRO DIGITALE	SPEEDOMETER, DIGITAL	COMPTEUR VITESSE NUMERIQUE	TACHOMETER DIGITAL	VELOCIMETRO DIGITAL
SM 500R	16	F000P00185	1	TACHIMETRO DIGITALE	SPEEDOMETER, DIGITAL	COMPTEUR VITESSE NUMERIQUE	TACHOMETER DIGITAL	VELOCIMETRO DIGITAL
	17	8000H0590	1	COMMUTATORE MAPPATURA	SWITCH, CALIBRATION DATA	COMMUTATEUR DONNEE	SCHALTER DATEN	CONMUTADOR DATOS
RS 300R - RS 500R	18	8A0099652	1	SENSORE VELOCITA'	SENSOR, SPEED	CAPTEUR VITESSE	ABTASTER GESCHWINDICKEIT	SENSOR VELOCIDAD
SM 500R	18	8B0099652	1	SENSORE VELOCITA'	SENSOR, SPEED	CAPTEUR VITESSE	ABTASTER GESCHWINDICKEIT	SENSOR VELOCIDAD
RS 300R - RS 500R	19	800092668	3	MOLLETTA FERMACAVO	CLAMP, WIRING	COLLIER, CORDON	KABELKLEMME	GRAMPA CORDON
SM 500R	19	8000A0664	3	MOLLETTA FERMACAVO	CLAMP, WIRING	COLLIER, CORDON	KABELKLEMME	GRAMPA CORDON
	20	8000A8903	1	COMMUTATORE A CHIAVE	MAIN SWITCH	COMMUTATEUR A CLE ALLUMAGE	ZUENDSCHALTER	CONMUTADOR LLAVE
	21	800074258	1	GHIERA COMMUTATORE A CHIAVE	RIM, MAIN SWITCH	CACHE COMMUTATEUR	RING, ZUENDSCHALTER	VIROLA CONMUTADOR LLAVE
	22	800035531	2	CHIAVE GREZZA	KEY, BLANK	CLE PAS CRANTEE	SCHLUSSEL NICHT GEZACKT	LLAVE SEMIACABADA
	23	F000P00115	1	SUPPORTO STRUMENTI	BRACKET METER	SUPPORT TABLEAU BORD	HALTERUNG INSTRUMENTENBRETT	SOPORTE TABLERO INSTRUMENTOS
	24	Z00067997	1	VITE TEF M5X0,8X12	SCREW TEF M5X0,8 CH8	VIS TEF M5X0,8 CH8	SCHRAUBE TEF M5X0,8 CH8	TORNILLO TEF M5X0,8 CH8
	25	F000P00571	1	PIASTRINA	PLATE	PLAQUE	PLATTE	PLACA

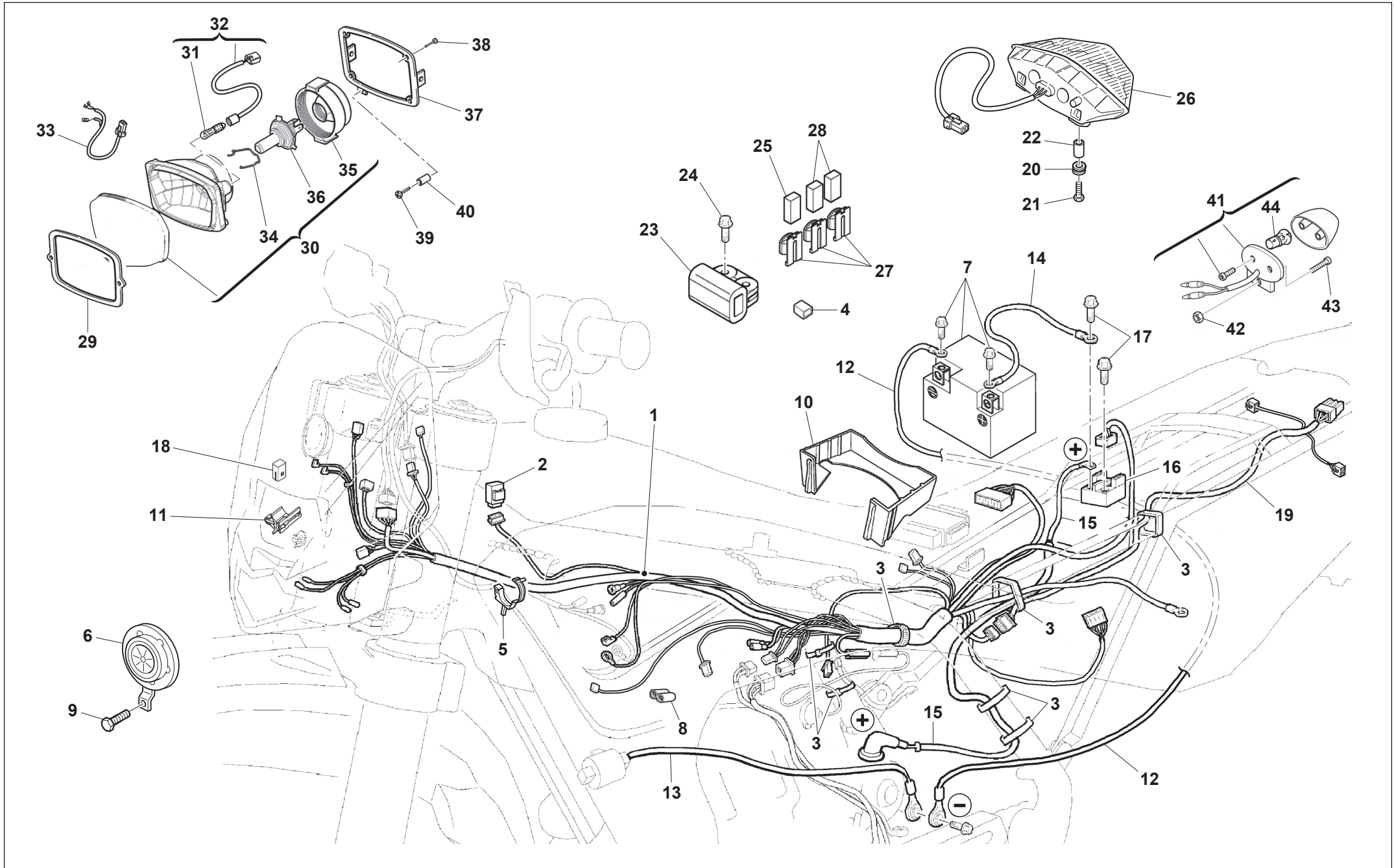



RS 300R/2016
RS 500R/2016
SM 500R/2016

GRUPPO CAVI, PARTI ELETTRICHE - MAIN WIRING HARNESS, ELECTRICAL PARTS
CABLES PRINCIPAL, PARTIES ELECTRIQUES - KABEL, ELEKTRISCHE KOMPONENTE
GRUPO PRINCIPAL CABLES, PARTES ELECTRICAS

TAVOLA
DRAWING
TABLE
BILD
TABLA

32

Note Notes Notas	Pos. No. N. Index Pos.	N. Cod. Code No. Nr. Code Code Nr N. Cod.	Q.tà Q.ty Q.te M.ge C.ad	DENOMINAZIONE	NAME	DESIGNATION	BESHREIBUNG	DENOMINACION
	1	E000P00133	1	IMPIANTO ELETTRICO	WIRING HARNESS	FAISCEAU CABLES PRINCIPAL	HAUPTVERKABELUNG	GRUPO CABLES PRINCIPAL
	2	8000A6749	3	RELE'	RELAY	RELAIS	RELAIS	RELE
	3	800056444	16	FASCETTA 188 mm	CLAMP 188 mm	COLLIER 188 mm	SHELLE 188 mm	ABRAZADERA 188 mm
RS 300R - RS 500R	4	8000A6774	1	TAPPO SENSORE CADUTA	PLUG SENSOR, LEAN ANGLE	BOUCHON CAPTEUR SECURITE CHUTE	VERSCHLUSS NEIGUNG ABTASTER	TAPON SENSOR INCLINACION
	5	8A0060283	2	FASCETTA FERMACAVO	GUIDE, CABLE	PASSE-CABLE	KABELDURCHGANG	PASACABLES
	6	E000A00026	1	AVVISATORE ACUSTICO	HORN	AVERTISSEUR SONORE	HUPE	AVISADOR ACÚSTICO
	7	8000A1891	1	BATTERIA 6AH	BATTERY 6AH	BATTERIE 6AH	BATTERIE 6AH	BATERIA 6AH
	8	8000A6477	1	TAPPO CONNETTORE	CAP, CONNECTOR	BOUCHON CONNECTEUR	VERSCHLUSS, STECKER	TAPON CONECTOR
	9	8000A6638		DISTANZIALE	SPACER	ENTRETOISE	ABSTANDHALTER	DISTANCIADOR
	10	8000H0159	1	SUPPORTO BATTERIA	BRACKET, BATTERY	SUPPORT BATTERIE	BATTERIEHALTERUNG	SOPORTE BATERIA
	11	8000H0644	2	CLIP	CLIP	JONC	KLAMMER	CLIP
	12	8000B0254	1	CAVO MASSA BATTERIA 890 mm	BATTERY-GROUND CABLE 890mm	CABLE BATTERIE-MASSE 890mm	KABEL BATTERIE-MASSE 890mm	CABLE BATERIA-MASA 890mm
	13	8000B0253	1	CAVO MASSA 460 mm	GROUND CABLE 460mm	CABLE MASSE 460mm	MASSE KABEL 460mm	CABLE MASA 460mm
	14	8000B0826	1	CAVO BATTERIA-TELERUTTORE	BATTERY-SOLENOID STARTER CABLE	CABLE BATTERIE-TELERUPTEUR	KABEL FUR BATTERIE-FERNCKONSOLE	CABLE BATERIA-TELERUPTOR
	15	8000H0267	1	CAVO MOTORINO AVVIAMENTO	WIRE STARTER MOTOR	CORDON MOTEUR DEMARRAGE	VERKABELUNG STARTERMOTOR	CABLEADO MOTOR ARRANQUE
	16	8000H0809	1	TELERUTTORE AVVIAMENTO	RELAY, STARTING MOTOR	RELAIS DEMARRAGE	STARTRELAIS	RELE ARRANQUE
	17	ZS0067545	2	VITE TEF M6X8	SCREW TEF M6X8	VIS TEF M6X8	SCHRAUBE TEF M6X8	TORNILLO TEF M6X8
	18	8000A6790	1	TAPPO CONNETTORE DIAGNOSI	PLUG CONNECTOR DIAGNOSTIC	BOUCHON CONNECTEUR DIAGNOSTIC	VERSCHLUSS DIAGNOSE STECKER	TAPON CONECTOR DIAGNOSIS
	19	8000H1176	1	CAVO FANALE POSTERIORE	CABLE, TAILLIGHT	CABLE FEU ARRIERE	KABELBAUM SCHLUSSLICHT	CABLE FARO PILOTO
	20	800095128	2	GOMMINO	GROMMET	CAOUTCHOUC	GUMMITEILE	GOMA
	21	Z00062727	2	VITE TEF M6X16	SCREW TEF M6X16	VIS TEF M6X16	SCHRAUBE TEF M6X16	TORNILLO TEF M6X16
	22	8000H1735	2	BOCCOLA FLANGIATA	BUSH WITH COLLAR	DOUILLE BRIDEE	GEFLANSCHBUCHSE	CASQUILLO REBORDEADO
SM 500R	23	8000A6756	1	SENSORE DI CADUTA	SENSOR, LEAN ANGLE	CAPTEUR SECURITE CHUTE	NEIGUNG ABTASTER	SENSOR INCLINACION
SM 500R	24	8000H0815	2	VITE	SCREW	VIS	SCHRAUBE	TORNILLO
	25	8G0095647	1	FUSIBILE 20A	FUSE 20A	FUSIBLE 20A	SICHERUNG 20A	FUSIBLE 20A
	26	8000H1418	1	FANALE POSTERIORE	TAIL LIGHT	FEU ARRIERE	SCHLUSSLICHT	LUZ COLA
	27	8000H0641	1	PORTAFUSIBILI	CASE, FUSE	CORPS PORTE-FUSIBLES	SICHERUNGSKASTEN	CUERPO PORTAFUSIBLES
	28	8F0095647	2	FUSIBILE 15A	FUSE 15A	FUSIBLE 15A	SICHERUNG 15A	FUSIBLE 15A
	29	8000A1053	1	GUARNIZIONE FANALE ANTERIORE	DAMPER, HEADLIGHT	JOINT FEU	SCHEINWERFERDICHTUNG	JUNTA FARO
	30	8000H1736	1	FANALE ANTERIORE	HEAD LIGHT	FEU AVANT	SCHEINWERFER	FARO DELANTERO
	31	800036230	1	LAMPADINA 12V 5W T10	WEDGE BASE BULB 12V5W T10	AMPOULE 12V 5W T10	GLUEHLAMPE 12V 5W T10	LAMPARA 12V 5W T10
	32	800095886	1	PORTALAMPADA POSIZIONE	SOCKET, PILOT LIGHT	PORTE AMPOULE, LAMPE-TEMOIN	FASSUNG, KONTROLLAMPE	PORTA-LAMPARA
	33	8000A6094	1	CAVO FANALE ANTERIORE	CORD, HEADLIGHT	CABLE FEU AVANT	VERKABELUNG SCHEINWERFER	CABLE FARO DELANTERO

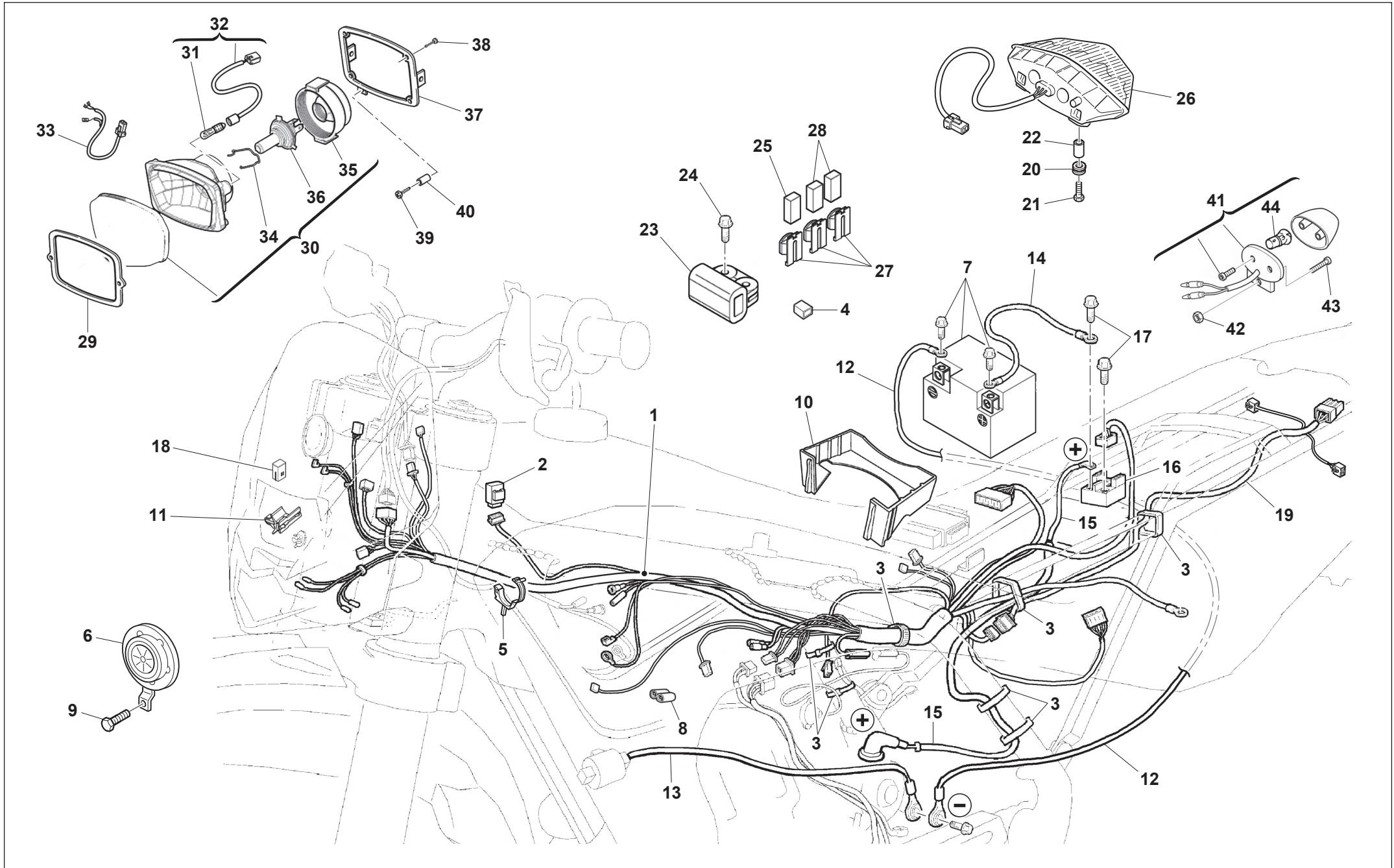

INFORMAZIONI IMPORTANTI
Pressione pneumatici a freddo

Solo guidatore	ANT.	Kg./cm ²	psi
	POST.	Kg./cm ²	psi
Guidat. e passegg.	ANT.	Kg./cm ²	psi
	POST.	Kg./cm ²	psi



4

3

5

2

6

1

8

9

bialbero

7

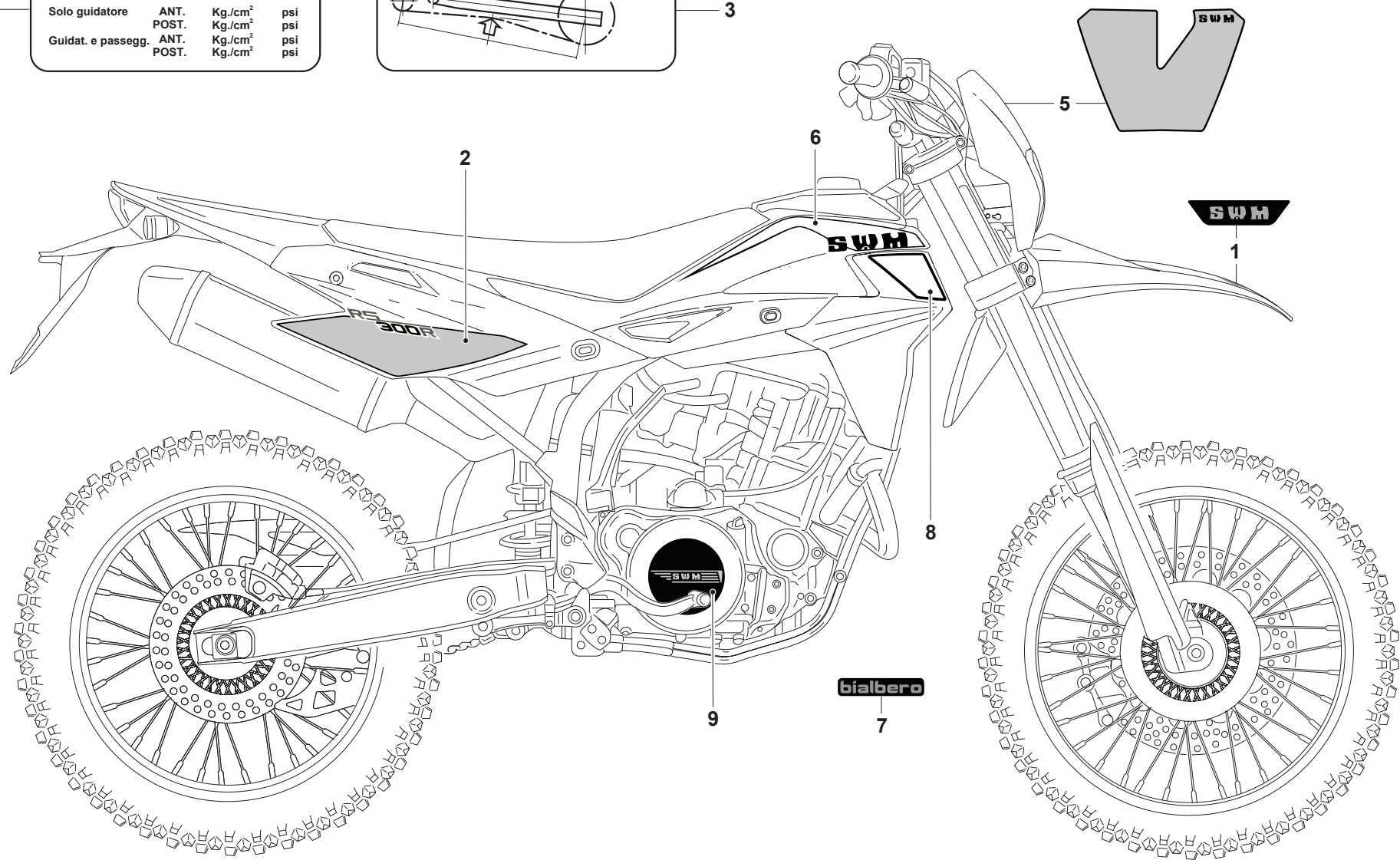

INFORMAZIONI IMPORTANTI

Pressione pneumatici a freddo

Solo guidatore	ANT.	Kg./cm ²	psi
	POST.	Kg./cm ²	psi
Guidat. e passegg.	ANT.	Kg./cm ²	psi
	POST.	Kg./cm ²	psi

REGOLAZIONE CATENA



4

3

5

2

6

1

8

9

bialbero

7

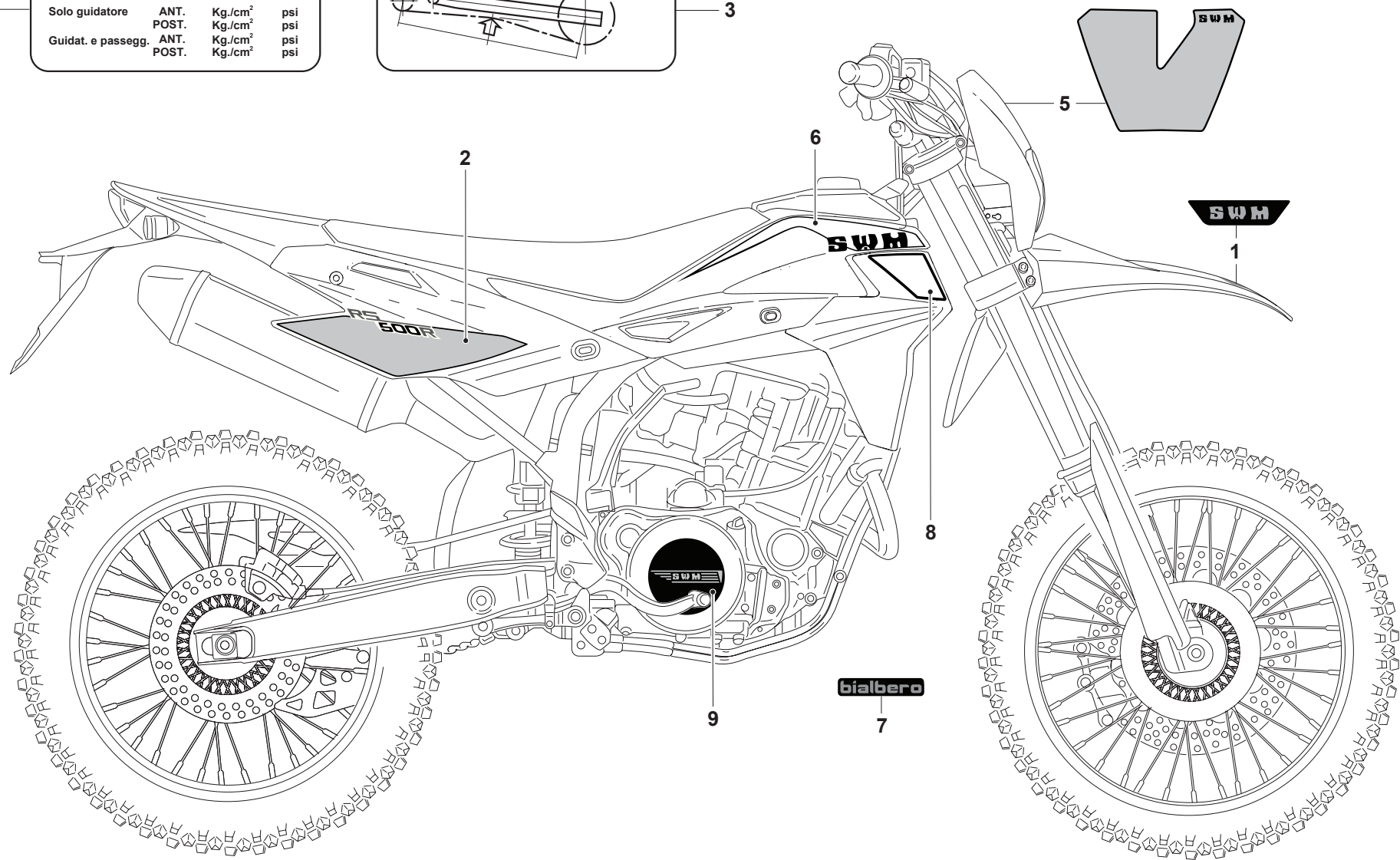

INFORMAZIONI IMPORTANTI

Pressione pneumatici a freddo

Solo guidatore	ANT.	Kg./cm ²	psi
	POST.	Kg./cm ²	psi
Guidat. e passegg.	ANT.	Kg./cm ²	psi
	POST.	Kg./cm ²	psi

REGOLAZIONE CATENA



4

3

5

2

6

1

8

9

7

